

Serie 04 > Basette Bases

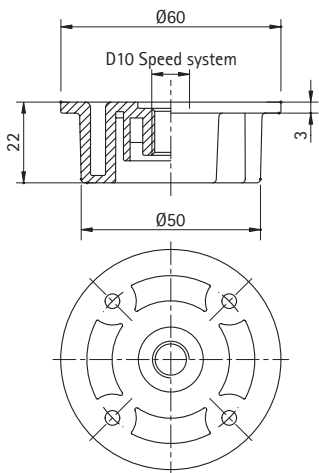

Doppio principio
Speed system

Code	pcs	kg	pcs
10/05.0400	400	10	4.000

Viti di fissaggio utilizzate

Screws to be used

10/07.131 – pag.39
10/07.137 – pag.39
10/07.138 – pag.39
10/07.139 – pag.40
10/07.211 – pag.40
10/07.212 – pag.40
10/07.222 – pag.41

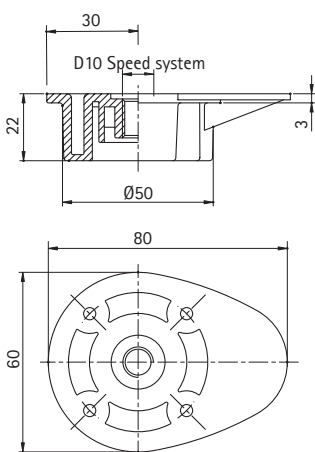

Doppio principio
Speed system

Code	pcs	kg	pcs
10/05.0500	400	11	4.000

Viti di fissaggio utilizzate

Screws to be used

10/07.131 – pag.39
10/07.137 – pag.39
10/07.138 – pag.39
10/07.139 – pag.40
10/07.211 – pag.40
10/07.212 – pag.40
10/07.222 – pag.41

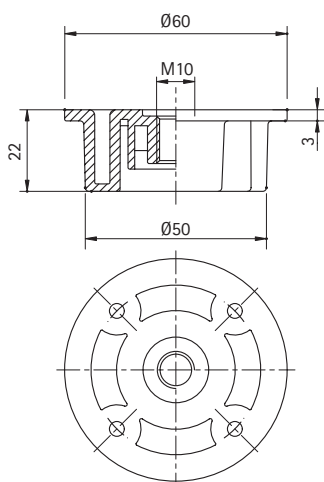

Code	pcs	kg	pcs
10/05.0251	400	10	4.000

Viti di fissaggio utilizzate

Screws to be used

10/07.111 – pag.41
10/07.121 – pag.41
10/07.122 – pag.42
10/07.124 – pag.42
10/07.125 – pag.42
10/07.128Z – pag.42
10/07.129 – pag.43