

VI**A > 100****Quote di posizionamento**

Reference points for positioning
 Cotes de positionnement
 Cotas de emplazamiento
 Stellungsmaass
 Отметки расположения
 Wymiary ustawiania

**VII****Rimuovere la guarnizione come indicato in figura.**

Remove the washer as shown in the picture.
 Interrompre le joint comme indiqué sur dessin.
 Sacar la goma como indicado.
 Entfernen die Dichtung wie Abbildung.
 Удалить уплотнитель, как показано на рисунке.
 Uszczelnienie usunąć jak wskazano na rysunku.

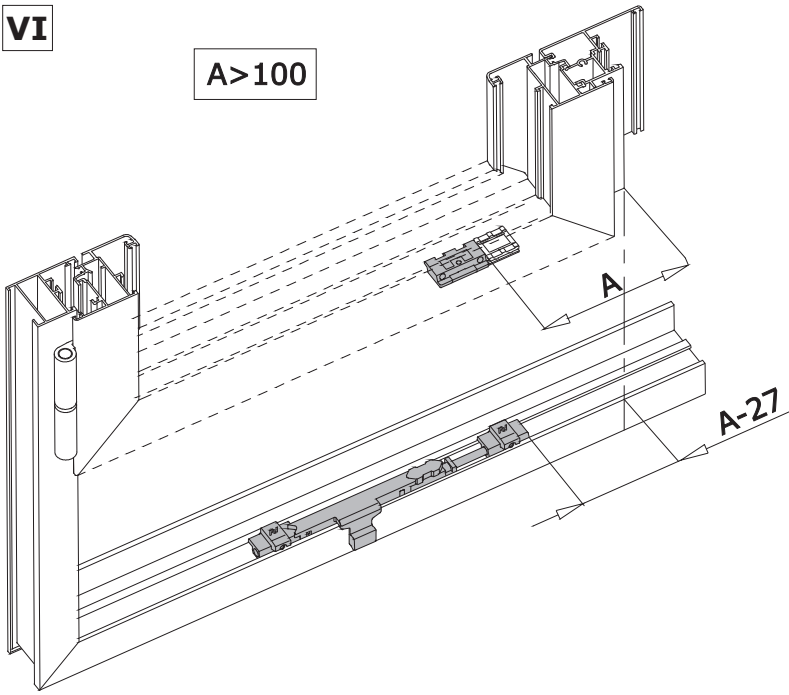
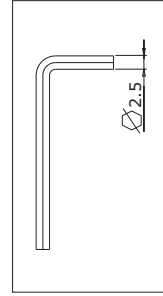
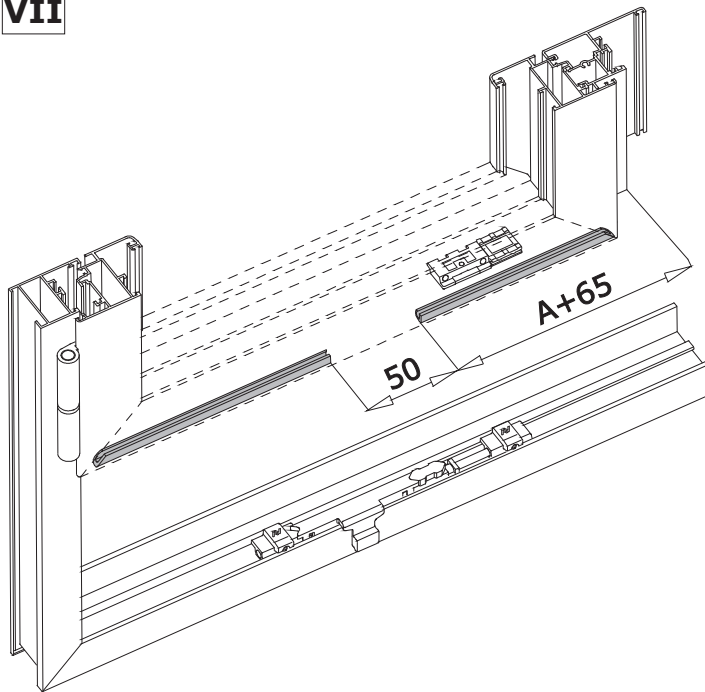