

Cerniera a 2 ali per aperture interne

2 wing hinge for internal openings

Paumelle à 2 lames pour ouvertures intérieures

Bisagra de 2 alas para aberturas internas

2 Flügeliges Band (Innen öffnend)

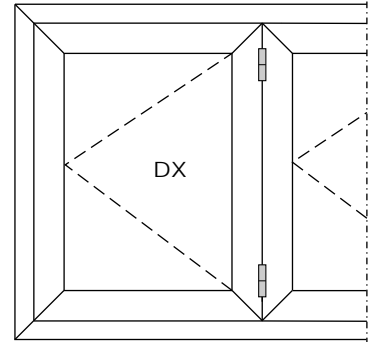
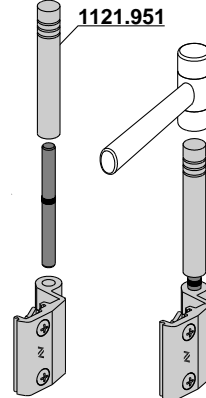
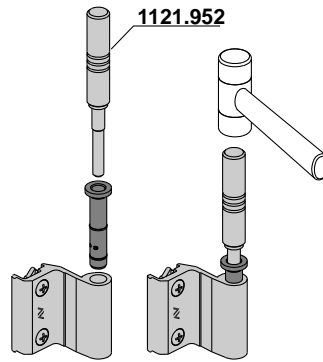
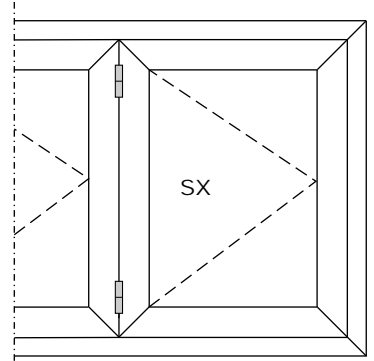
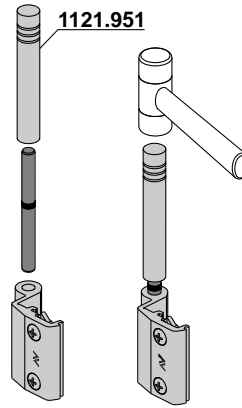
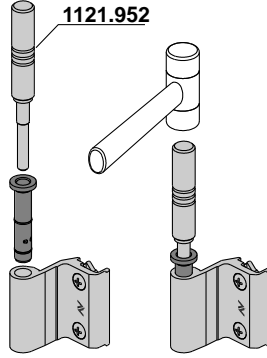
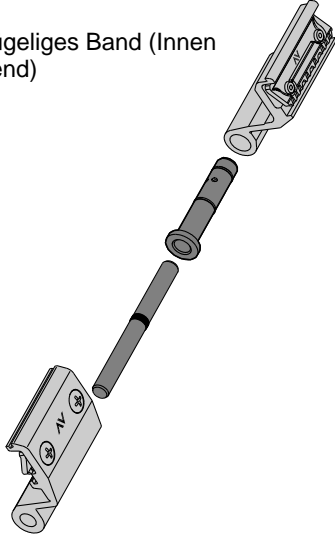

Asportare la guarnizione
Remove the gasket
Enlever le joint
Sacar la junta
Dichtung entfernen

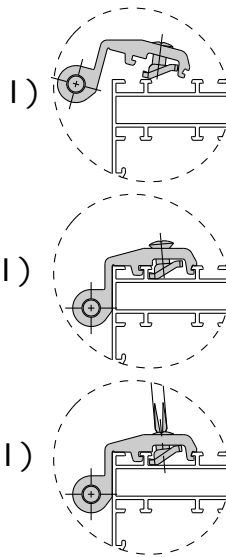
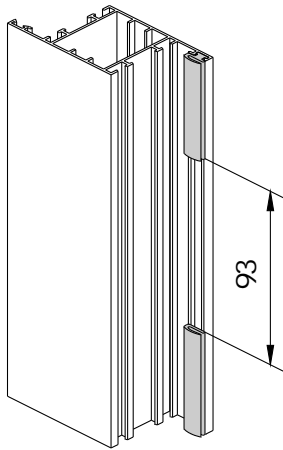

Sequenza di montaggio
Sequence assembly
Séquence de montage
Secuencia de montaje
Montage Reihenfolge

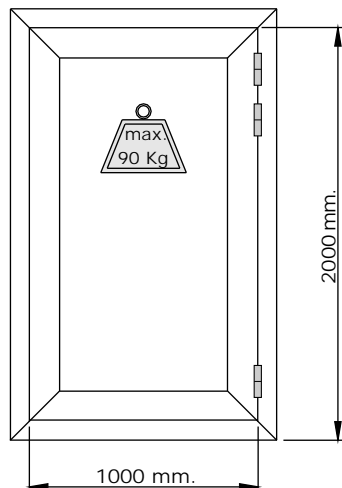
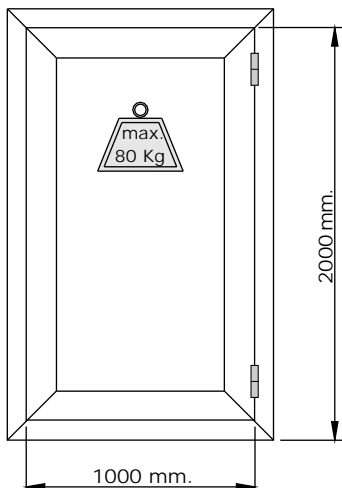
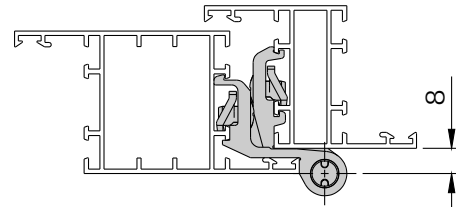

Tabella di adattabilità per profili italiani
Suitability table for italian profile

Estrusore	Profilo
SAPA	R40/50 TT barra cont./60 TT/62 TT/72 TT
PONZIO SUD	NEW TEC 50/52/60F/60 TT/68 TT
CLL	TECNO 50/50 TT/60 TT/68 TT
ETNALL	40500/TT50
ALLU SISTEMI	RX600/RX700
PRESAL EXTRUSION	PR66TT/PR75TT