

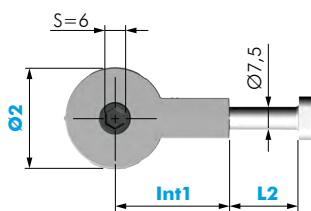

### CARATTERISTICHE:

- GIUNZIONE IDEALE PER UNIRE DUE TOP O DUE PANNELLI
- FORMATA DAL CORPO CON TIRANTE E DALLA SEDE PER IL TIRANTE
- UNISCE IL MOBILE IN MODO SOLIDO E STABILE

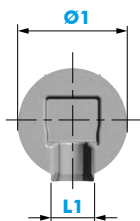
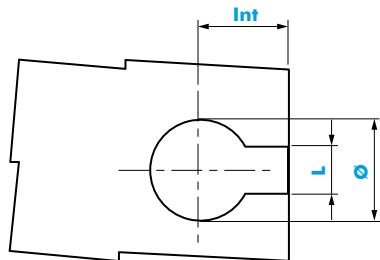
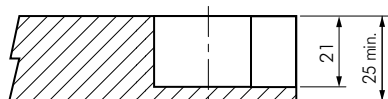

SL	CODICE	DESCRIZIONE	GIUNTO	INT	L	L1	Ø	Ø1	MATERIALE	QUANTITÀ
≥25	21610010	SEDE TOP QUICK	21611010	26	14	13,5	30	29,7	PLAST	700
			21611020	124						
	21620010		21621010	32	15	14	35	34,7		A RICHIESTA
			21621020	118						
			21621040	68						



SL	CODICE	DESCRIZIONE	INT1	L2	Ø2	MATERIALE	QUANTITÀ
≥25	21611010	GIUNTO TOP QUICK	26	15,5	30	ZAMA PLAST FE	350
	21611020			113,5			150
	21621010		24	35	250		
			21621020		60		150
			21621040		110		

## INSTALLAZIONE TOP QUICK

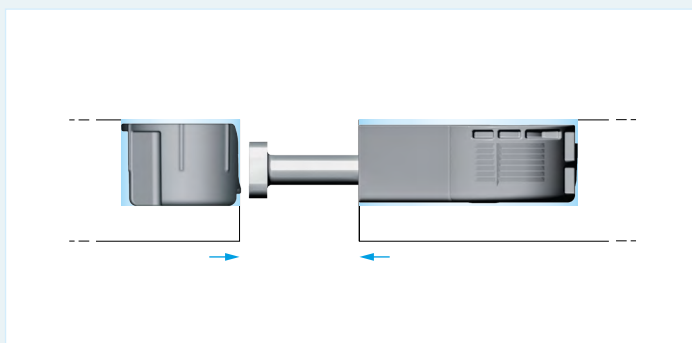

1. SERRAGGIO DEL TOP

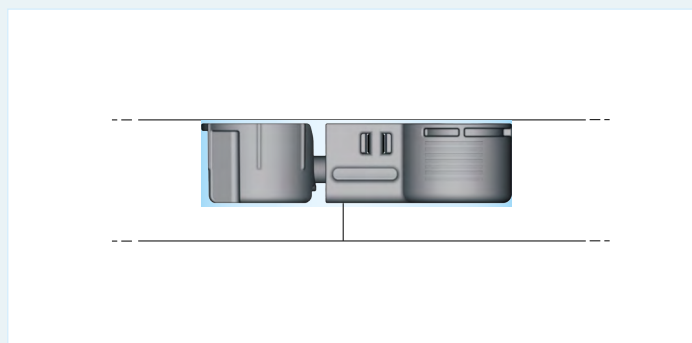

2. APPLICAZIONE