



Italian passion,
artisan details

HANDLES CATALOG

→ CONTEMPORARY COLLECTION

PAG.	COD.	SERIE CONTEMPORARY
7	CT256	BRERA
9	CT255	MATT
11	CT255+	MATT+LEATHER
13	CT257	MOSCOW CITY
15	CT258	PORTOFINO
17	CT259	MAYFAIR
19	CT260	TORTONA
21	CT260+	TORTONA+MARBLE
23	CT261	LAMBRATE
25	CT262	CITYLIFE
27	CT263	PARIOLI
29	CT264	ABBOTT KINNEY
31	CT265	AMALFI
33	CT254	WALL
35	CT7060	STREET

→ ACCESSORIS CONTEMPORARY

PAG.	COD.	SERIE
38	AC7060	CONTEMPORARY TONDA
39	AC254	CONTEMPORARY QUADRA
41	AC2570M	CONTEMPORARY MINIMAL

→ BRONZE COLLECTION

PAG.	COD.	SERIE BRONZE
45	BR80	OTTA
47	BR20	ASPEN
49	BR10	TRUCKEE
51	BR30	ZERMATT
53	BR40	WANAKA
55	BR50	CORTINA
57	BR60	CHAMONIX
59	BR70	COURMAYEUR

→ ACCESSORIS BRONZE

PAG.	COD.	
61	AB9103	ACCESSORIES

→ CREMONE BOLTS | CREMONESI ASTE ESTERNE

PAG.	COD.	
63	CT83-CT82	CREMONE BOLTS

→ PRODUCTS

PAG.	COD.	
65	H	LIFT & SLIDE
69	L	PULL HANDLES
73	P	DOOR KNOBS

→ INFORMATION

74	TECNICAL DETAILS
83	FINISHES
85	MATERIA
87	CONTACT

Contem

—porary

Collec—

tion



Italian passion,
artisan details

CT256



APEXFINE
LUXURY LIGHTING
Pozzallo

Arch Kai Sade — Photographer Amit Geron



CONTEMPORARY COLLECTION

serie Brera

LF DESIGN

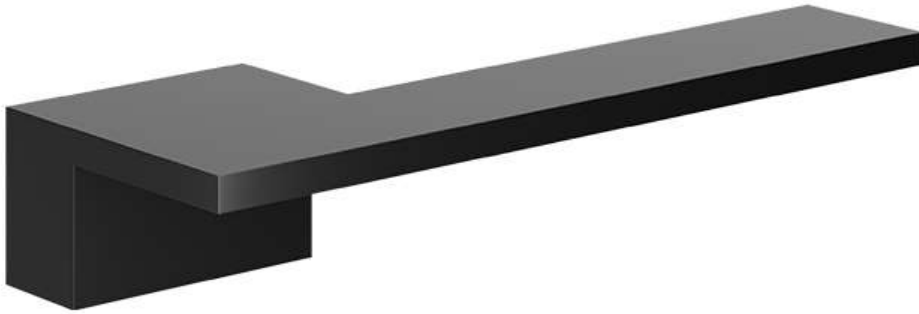

CT256RNST

				
CT256KSXNST	CT256KDXNST	CT257HNS	CT257LNST	AC254PONST

MATERIAL ALLUMINIUM

FINISH BLACK SOFT TOUCH

CONTEMPORARY FINISHES





Italian passion,
artisan details

CT255



CONTEMPORARY COLLECTION



serie Matt

Arch. A. Piubello



CT255RSANO

				
CT255VSANO	CT255KSANO	CT255HSANO	CT255LSANO	AC7060PONO

MATERIAL ZAMAK + BRASS

FINISH BLACK + NATURAL BRASS

CONTEMPORARY FINISHES



OSO

ON

OLV

NST

NO

CS

CR

OBGV

BO

BA

FA



Italian passion,
artisan details

CT255+



CONTEMPORARY COLLECTION



serie Matt + Leather

Arch. A. Piubello

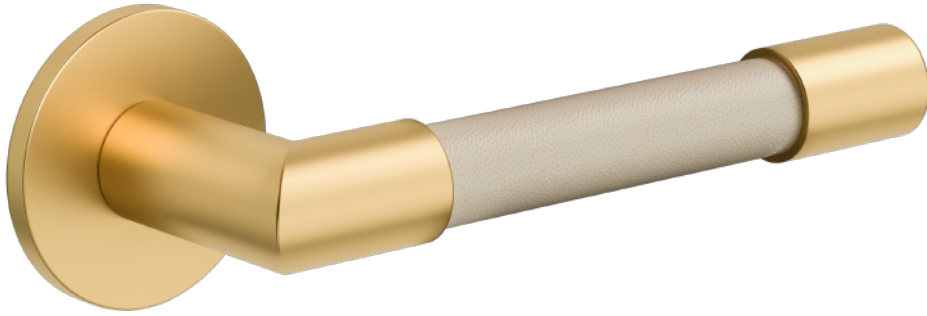

CT255RNOLW

CT255VNOLW	CT255KNOLW	CT255HNOLW	CT255LSNOLW	AC060POON

MATERIAL ZAMAK + LEATHER

FINISH NATURAL BRASS + WHITE

CONTEMPORARY FINISHES



OSO

ON

OLV

NST

NO

CS

CR

OBGV

BO

BA

FA



Italian passion,
artisan details

CT257

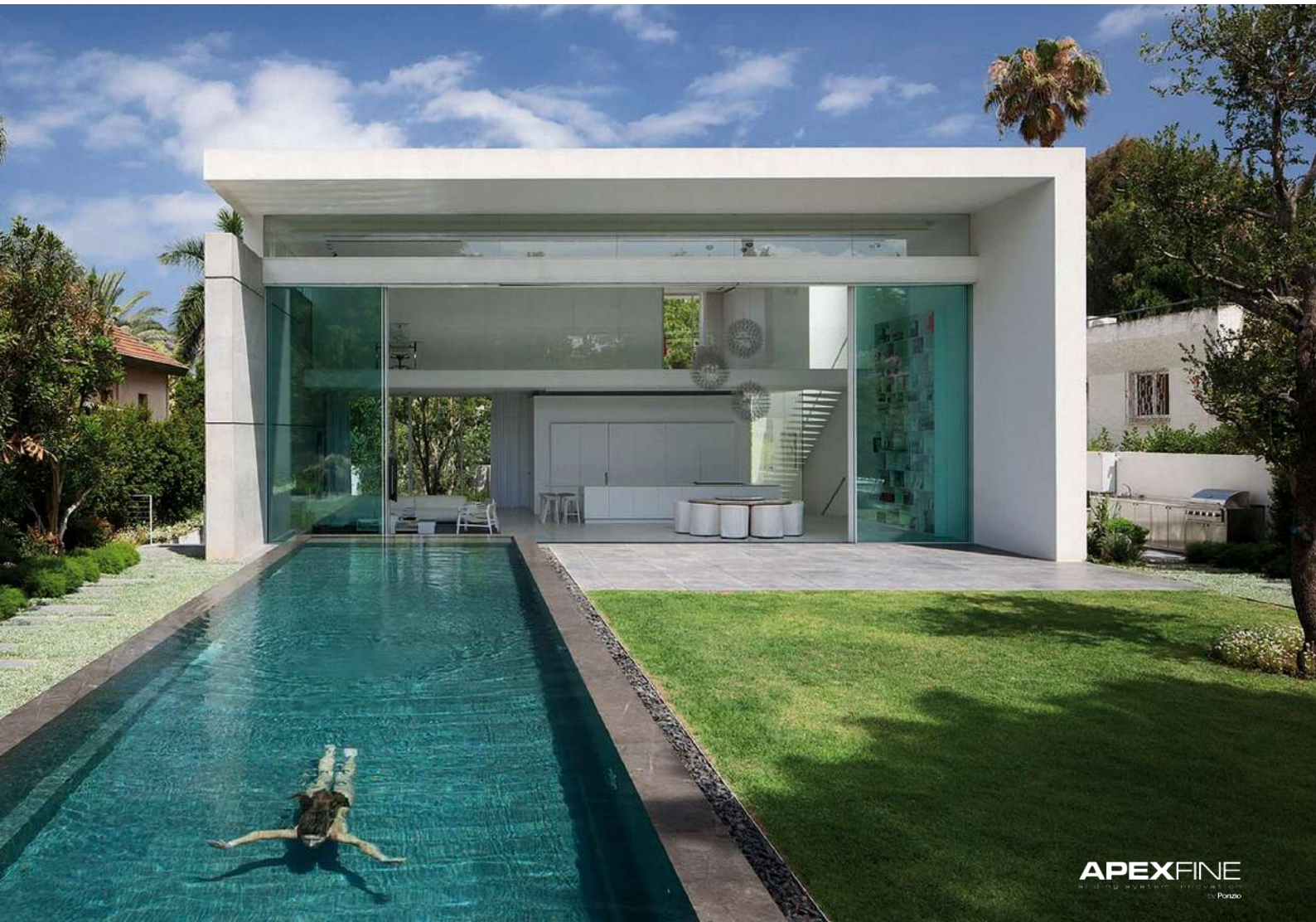

APEXFINE
DESIGN FOR THE CONTEMPORARY HOME
Portofino

Arch Pitsou Kedem — Photographer Amit Geron



CONTEMPORARY COLLECTION

serie Moscow City

LF DESIGN



CT255RNST

CT257KNST	CT257HNST	CT257LNST	AC254PONST

MATERIAL ALLUMINIUM

FINISH BLACK SOFT TOUCH

CONTEMPORARY FINISHES



OSO

ON

OLV

NST

NO

CS

CR

OBGV

BO

BA

FA



Italian passion,
artisan details

CT258



Arch Orly Shrem — Photographer Amit Geron

CONTEMPORARY COLLECTION

serie Portofino

LF DESIGN

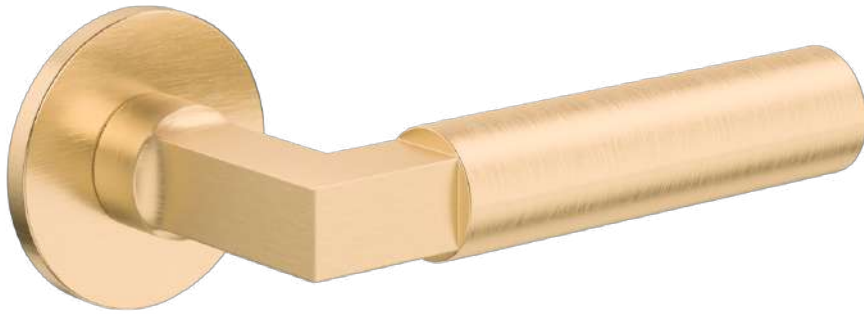

CT258RON

				
CT258VON	CT258KON	CT258HON	CT258LON	AC060POON

MATERIAL BRASS

FINISH NATURAL BRASS

CONTEMPORARY FINISHES



OSO

ON

OLV

NST

NO

CS

CR

OBGV

BO

BA

FA



Italian passion,
artisan details

CT259



Arch: Pini Davidovich

Photo: Amit Geron

APEXFINE
LIVING SOLUTIONS
BY PIANO

Arch: Pitsou Kedem — Photographer: Amit Geron

CONTEMPORARY COLLECTION

serie Mayfair

LF DESIGN



CT259RNO

				
CT259VNO	CT259KNO	CT259HNO	CT259LNO	AC7060PONO

MATERIAL ALLUMINIUM

FINISH BLACK MATT

CONTEMPORARY FINISHES



OSO

ON

OLV

NST

NO

CS

CR

OBGV

BO

BA

FA



Italian passion,
artisan details

CT260



CONTEMPORARY COLLECTION

serie Tortona

LF DESIGN



CT260RCS

				
CT260VCS	CT260KCS	CT260HCS	CT260LCS	AC254POCS

MATERIAL BRASS

FINISH CHROME MATT

CONTEMPORARY FINISHES



OSO

ON

OLV

NST

NO

CS

CR

OBGV

BO

BA

FA



Italian passion,
artisan details

CT260+



Arch Pitsou Kedem — Photographer Amit Geron

CONTEMPORARY COLLECTION

serie Tortona + Marble

Partner Marmi Galli



CT260RONMR

				
CT260VONMR	CT260KONMR	CT260HONMR	CT260LONMR	AC060POON

MATERIALI BRASS & MARBLE

CONTEMPORARY FINISHES



OSO

ON

OLV

NST

NO

CS

CR

OBGV

BO

BA

FA

LE
FABRIC

Italian passion,
artisan details

CT261



CONTEMPORARY COLLECTION

serie Lambrate

LF DESIGN



CT261RON

CT261VON	CT261KON	CT261HON	CT261LON	AC060POON

MATERIAL BRASS

FINISH NATURAL BRASS

CONTEMPORARY FINISHES



OSO

ON

OLV

NST

NO

CS

CR

OBGV

BO

BA

FA



Italian passion,
artisan details

CT262



Arch Peri Davidovich — Photo Amit Geron

CONTEMPORARY COLLECTION

serie CityLife

LF DESIGN

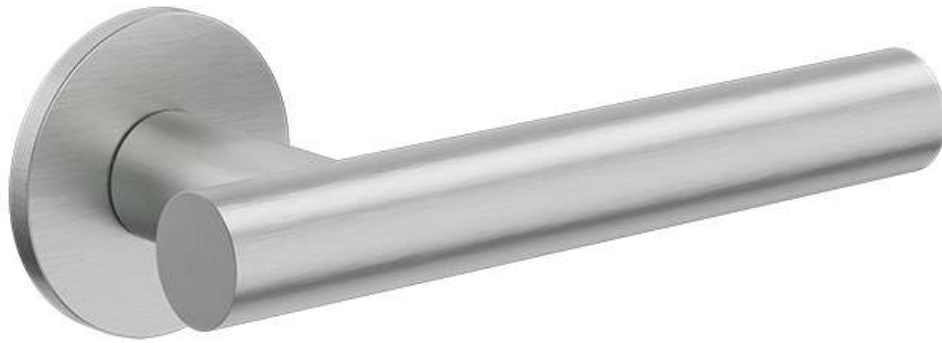

CT262RCS

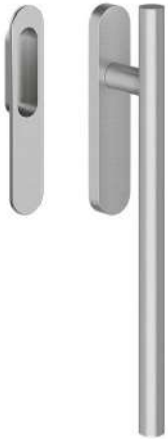
				
CT262VCS	CT262KCS	CT262HCS	CT262LCS	AC7060POCS

MATERIAL BRASS

FINISH CHROME MATT

CONTEMPORARY FINISHES



OSO

ON

OLV

NST

NO

CS

CR

OBGV

BO

BA

FA



Italian passion,
artisan details

CT263



CONTEMPORARY COLLECTION

serie Parioli

LF DESIGN



CT263RON

CT263VON	CT263KON	CT263HON	CT263LON	AC060POON

MATERIAL BRASS

FINISH NATURAL BRASS

CONTEMPORARY FINISHES



OSO

ON

OLV

NST

NO

CS

CR

OBGV

BO

BA

FA



Italian passion,
artisan details

CT264



CONTEMPORARY COLLECTION

serie Abbott Kinney

LF DESIGN



CT264RNO

CT264VNO	CT264KNO	CT264HNO	CT264LNO	AC7060PONST

MATERIAL IRON

FINISH BLACK MATT

CONTEMPORARY FINISHES



OSO

ON

OLV

NST

NO

CS

CR

OBGV

BO

BA

FA



Italian passion,
artisan details

CT265



Arch Peri Davidovich — Photo Amit Geron

CONTEMPORARY COLLECTION

serie Amalfi

LF DESIGN



CT265RNO

CT265VNO	CT265KNO	CT265HNO	CT265LNO	AC254PONO

MATERIAL BRASS

FINISH BLACK MATT

CONTEMPORARY FINISHES





Italian passion,
artisan details

CT254



CONTEMPORARY COLLECTION



serie Wall

Arch. R. Rocchi

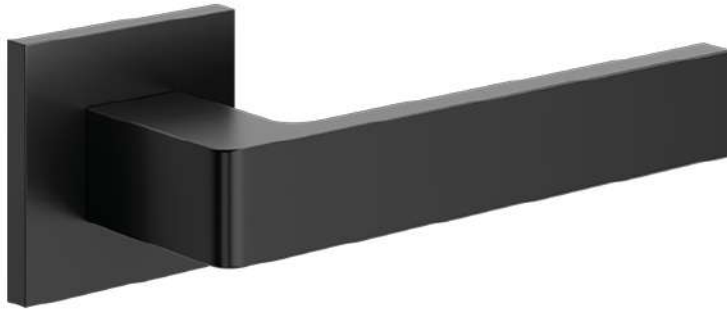

CT264RNO



-CO



-CR

CT264V-	CT264K-	CT264H-	CT264L-	AC254P-

MATERIAL ZAMAK

FINISHES MATT BLACK – MATT CHROME – POLISHED CHROME

CONTEMPORARY FINISHES



OSO

ON

OLV

NST

NO

CS

CR

OBGV

BO

BA

FA



Italian passion,
artisan details

CT7060



CONTEMPORARY COLLECTION



serie Street

Arch. R. Rocchi



CT7060RCS



-ON

CT7060V-	CT7060K-	CT7060H-	CT7060L-	AC7060P-

MATERIALI ZAMAK

FINISHES MATT BRASS – MATT CHROME – POLISHED CHROME

CONTEMPORARY FINISHES



OSO

ON

OLV

NST

NO

CS

CR

OBGV

BO

BA

FA

Acces—

sori

—es

Accessories Tonda Contemporary

		
AC7060BP	AC7060BY	AC7060WC

		
AC7060BC	AC7060PC	AC7060VY

		
AC7060KT	AC7060KS	AC7060KP

MATERIAL BRASS

FINISHES

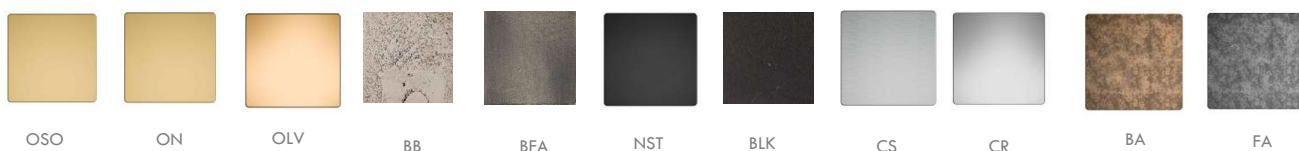

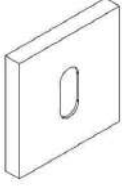
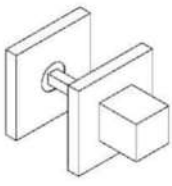

Accessories **Quadra** Contemporary

LF DESIGN

		
AC254BP	AC254BY	AC254WC

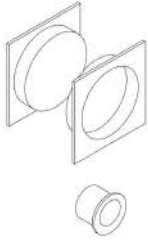
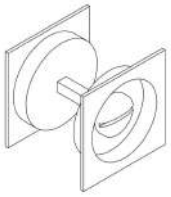
		
AC254BC	AC254P	AC254VY

		
AC254KT	AC254KS	AC254KP

MATERIAL BRASS

FINISHES

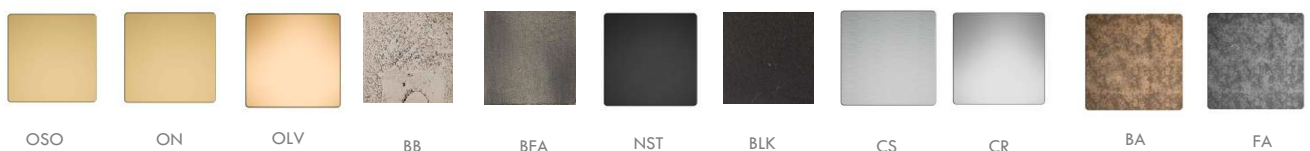



Italian passion,
artisan details

Accessories Minimal

LF DESIGN

		
AC7060MP	AC7060MY	AC7060MR

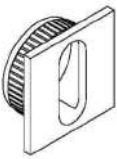
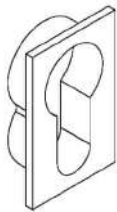
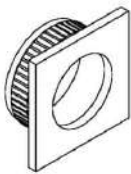
		
AC254MP	AC254MY	AC254MR

MATERIAL BRASS

FINISHES

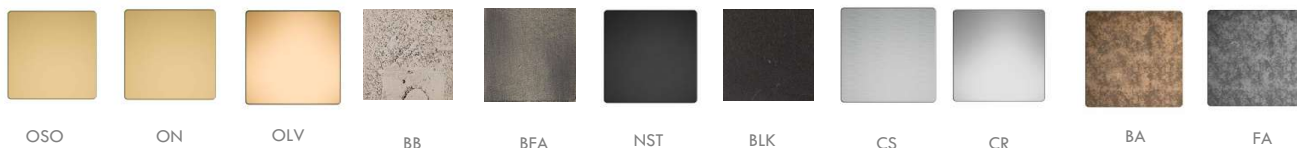

Bronze

Collec—

tion



Italian passion,
artisan details

BR80



BRONZE COLLECTION



serie Otta

Arch. R. Rocchi



BR80RBLK

CT7060KBLK	CT7060HBLK	CT7060LBLK	AC7060PBLK

MATERIAL BRONZE

FINISH BLACK BRONZE

BRONZE FINISHES



BLK

VI

BN

BB

BFA

NST

OL

CS

CR



Italian passion,
artisan details

BR20







BRONZE COLLECTION

serie Aspen

LF DESIGN



BR20RBN

				
BR20VBN	BR20KSXBN	BR20KDXBN	BR20HBN	BR20LBN

MATERIAL BRONZE

FINISH NATURAL BRONZE

BRONZE FINISHES

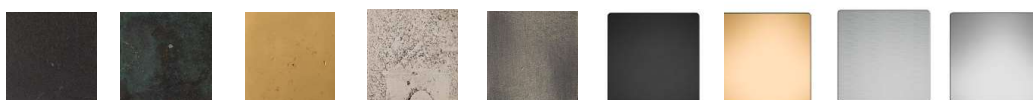

BLK

VI

BN

BB

BFA

NST

OL

CS

CR



Italian passion,
artisan details

BR10



BRONZE COLLECTION

serie Truckee

LF DESIGN



BR10RBB

BR10VBB	BR10KSXBB	BR10KDXBB	BR10HBB	BR10LBB

MATERIAL BRONZE

FINISH WHITE BRONZE

BRONZE FINISHES



BLK

VI

BN

BB

BFA

NST

OL

CS

CR



Italian passion,
artisan details

BR30



BRONZE COLLECTION

serie Zermatt

LF DESIGN



BR30RVI

			
BR30VVI	BR30KVI	BR30HVI	BR30LVI

MATERIAL BRONZE

FINISH DEEP GREEN BRONZE

BRONZE FINISHES

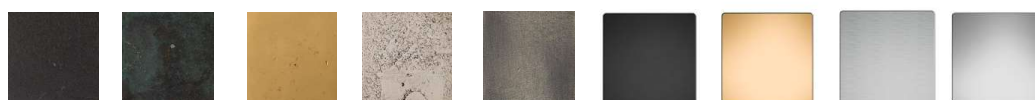

BLK

VI

BN

BB

BFA

NST

OL

CS

CR



Italian passion,
artisan details

BR40



BRONZE COLLECTION

serie Wanaka

LF DESIGN



BR40RBN

			
BR40VBN	BR40KBN	BR40HBN	BR40LBN

MATERIAL BRONZE

FINISH NATURAL BRONZE

BRONZE FINISHES

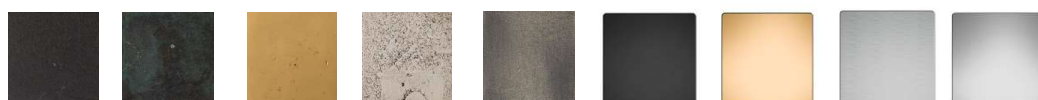

BLK

VI

BN

BB

BFA

NST

OL

CS

CR

LE
FABRIC

Italian passion,
artisan details

BR50



BRONZE COLLECTION

serie Cortina

LF DESIGN



BR50RBB

BR50VBB	BR50KBB	BR50HBB	BR50LBB

MATERIAL BRONZE

FINISH NATURAL BRONZE

BRONZE FINISHES



BLK

VI

BN

BB

BFA

NST

OL

CS

CR



Italian passion,
artisan details

BR60



BRONZE COLLECTION

serie Chamonix

LF DESIGN



BR60RBB

BR60VBB	BR60KBB	BR60HBB	BR60LBB

MATERIAL BRONZE

FINISH WHITE BRONZE

BRONZE FINISHES



BLK

VI

BN

BB

BFA

NST

OL

CS

CR

LE
FABRIC

Italian passion,
artisan details

BR70



BRONZE COLLECTION

serie Courmayeur

LF DESIGN



BR70RBFA

BR70VBFA	BR70KBFA	BR70HBFA	BR70LBFA

MATERIAL BRONZE

FINISH NATURAL BRONZE

BRONZE FINISHES



BLK

VI

BN

BB

BFA

NST

OL

CS

CR



Acces—

sori

—es

Accessories Bronze

		
AB9103R75	AB9103R50	AB9103V75

		
AB9103P5024	AB9103P40	AB9103P5027

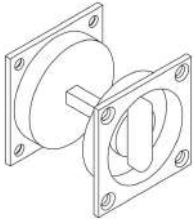
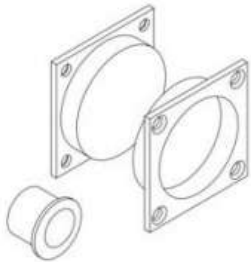
		
AB9103WC	AB9101	AB9102

MATERIAL BRONZE

BRONZE FINISHES

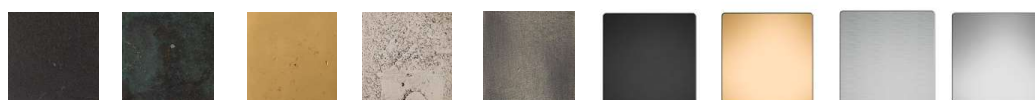

BLK

VI

BN

BB

BFA

NST

OL

CS

CR

Cremona

— nesi

Cremone Bolt for external rods

MANIGLIE CREMONESI CON ASTE ESTERNE

			
CT83KPON	CT83KMON	CT82KPON	CT82KMON

			
CT82FION	CT82CAON	CT83CAON	CT82ASON

MATERIAL BRASS

FINISH NATURALBRASS

FINISHES



OSO



ON



OLV



BB



BFA



NST



BLK



CS



CR



BA

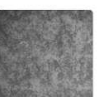



FA



Lift & Slide Windows

MANIGLIE ALZANTI SCORREVOLI PER FINESTRE



serie **Bronze**

		
CT7060BLK	BR20HBN	BR10HBB

		
BR30HVI	BR40HBN	BR50HBB

	
BR60HBB	BR70HBFA

MANIGLIONE PER ALZANTE
E MANIGLIA A
CONCHIGLIA DI
TRASCINAMENTO

DISPONIBILI MANIGLIONI
ACCOPPIATI

*HANDLE AND SHELL FOR
LIFT AND SLIDE DOOR*

PAIR HANDLE AVAILABLE

MATERIAL BRONZE

BRONZE FINISHES



BLK

VI

BN

BB

BFA



NST

Lift & Slide Windows

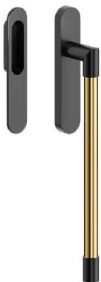
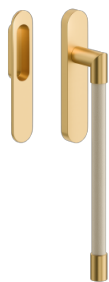
MANIGLIE ALZANTI SCORREVOLI PER FINESTRE

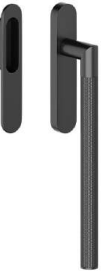
		
CT257HNS	CT255HSANO	CT255HNOLW

		
CT258HON	CT259HNO	CT260HCS

		
CT260HONMR	CT261HON	CT262HCS

MATERIAL BRASS - ZAMAK - ALLUMINIUM

CONTEMPORARY FINISHES



serie Contemporary

		
CT263HON	CT264HNO	CT265HNO

		
CT264HNO	CT264HCS	CT264HCR

	
CT7060HCO	CT7060HNO

MANIGLIONE PER ALZANTE
E MANIGLIA A
CONCHIGLIA DI
TRASCINAMENTO

DISPONIBILI MANIGLIONI
ACCOPPIATI

*HANDLE AND SHELL FOR
LIFT AND SLIDE DOOR*

PAIR HANDLE AVAILABLE

MATERIAL BRASS - ZAMAK - ALLUMINIUM

BRONZE FINISHES



BLK

VI

BN

BB

BFA



NST



Pull Handles

MANIGLIONI PER PORTE INGRESSO



Serie Bronze

		
AC7060BLK	BR20LBN	BR10LBB

		
BR30LVI	BR40LBN	BR50LBB

	
BR60LBB	BR70LBFA

DISPONIBILI CON ROSETTE

TIPOLOGIA DI FISSAGGIO
DA SPECIFICARE IN ORDINE

AVAILABLE WITH ROSES

FIXING KIT TO BE
SPECIFICATE ON ORDER

MATERIAL BRONZE

FINISHES



BLK

VI

BN

BB

BFA

CS

CR

OBGV

ON

BA



FA

Pull Handles

MANIGLIONI PER PORTE INGRESSO

		
CT257LNST	CT255LSANO	CT255LSNOLW

		
CT258LON	CT259LNO	CT260LCS

		
CT260LONMR	CT261LON	CT262LCS

MATERIAL BRONZE – BRASS – ZAMAK – ALLUMINIUM

CONTEMPORARY FINISHES



serie Contemporary

		
CT263LON	CT264LNO	CT265LNO

		
CT264LNO	CT264LCO	CT264LCR

	
CT7060LCS	CT7060LON

DISPONIBILI CON ROSETTE
 TIPOLOGIA DI FISSAGGIO
 DA SPECIFICARE IN ORDINE

AVAILABLE WITH ROSES

*FIXING KIT TO BE
 SPECIFICATE ON ORDER*

MATERIAL BRASS – ZAMAK – ALLUMINIUM

BRONZE FINISHES



BLK

VI

BN

BB

BFA

NST

Entrance Hall

POMOLI PER PORTE INGRESSO



Door Knobs

POMOLI PER PORTE INGRESSO

		
AC060POCO	AC060POON	AC060PONO

		
AC254PCR	AC254PNO	AC254PCO

POMELLO SINGOLO PER PORTA, FISSO, CON SISTEMA MONTAGGIO STANDARD PER LEGNO.
DISPONIBILI SU RICHIESTA POMOLI ACCOPPIATI CON MOLLA.

*FIXED KNOBS ON ROSES WITH SMALL PLATE AND WOOD SCREWS FIXING.
AVAILABLE KNOBSET ON ROSES.*

MATERIAL BRASS

CONTEMPORARY FINISHES

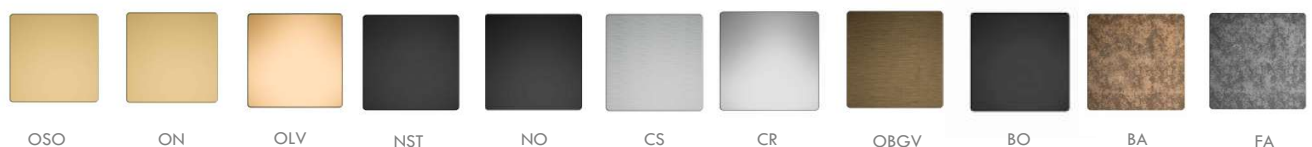

Technical Details

Brera CT256

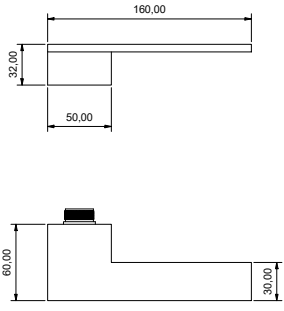
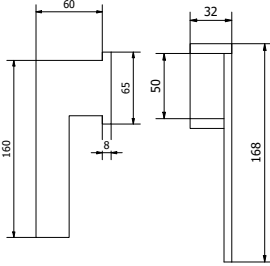
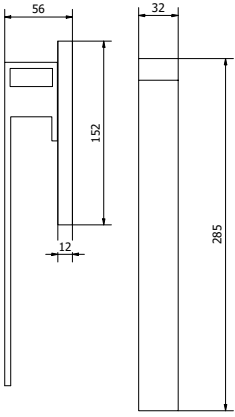
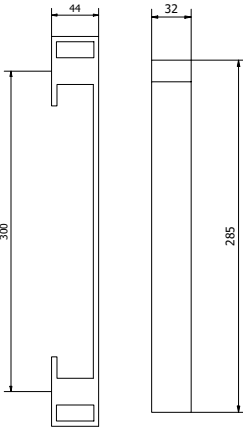
			
<p>R - DOOR</p>	<p>K - WINDOWS DK</p>	<p>H - LIFT UP SLIDING</p>	<p>L - PULL DOOR</p>

Matt CT255

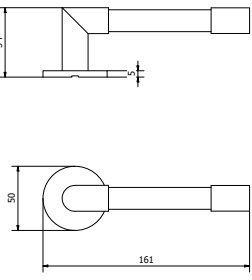
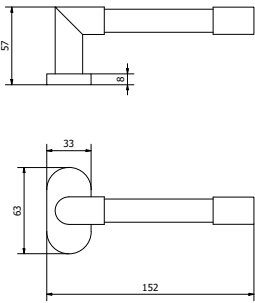
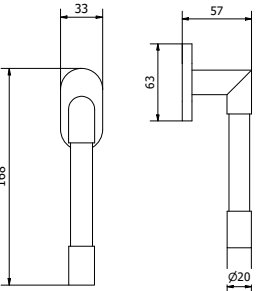
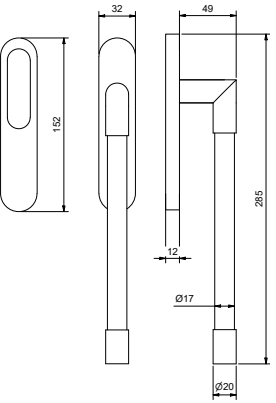
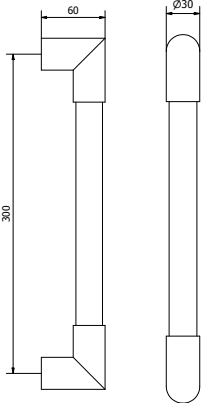
				
<p>R - DOOR</p>	<p>V - SLIM FRAME</p>	<p>K - WINDOWS DK</p>	<p>H - LIFT & SLIDE</p>	<p>L - PULL HANDLES</p>

Moscow City CT257

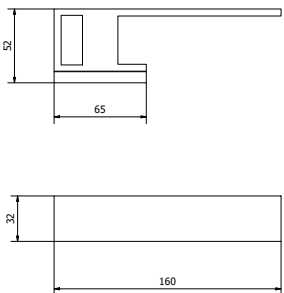
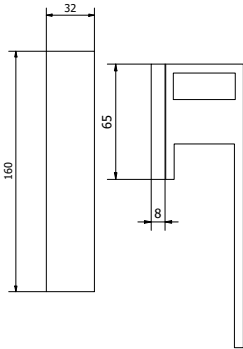
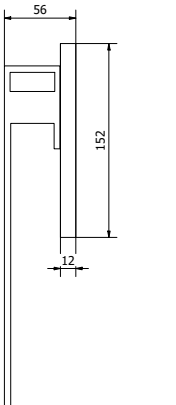
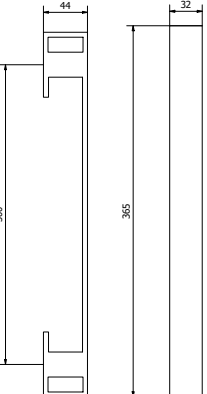
			
<p>R - DOOR</p>	<p>V - SLIM FRAME</p>	<p>H - LIFT UP SLIDING</p>	<p>L - PULL DOOR</p>

serie Contemporary

Portofino CT258

<p>Technical drawings of the door handle (R) and slim frame (V) for the Portofino CT258 series. The door handle (R) has a height of 64 and a width of 137. The slim frame (V) has a height of 64 and a width of 127. Both have a diameter of 50.</p>	<p>Technical drawings of the window handle (K) and lift & slide handle (H) for the Portofino CT258 series. The window handle (K) has a height of 145 and a width of 33. The lift & slide handle (H) has a height of 220 and a width of 32. The slim frame (V) has a height of 64 and a width of 127.</p>	<p>Technical drawings of the window handle (K) and lift & slide handle (H) for the Portofino CT258 series. The window handle (K) has a height of 145 and a width of 33. The lift & slide handle (H) has a height of 220 and a width of 32. The slim frame (V) has a height of 64 and a width of 127.</p>	<p>Technical drawings of the lift & slide handle (H) and pull handle (L) for the Portofino CT258 series. The lift & slide handle (H) has a height of 220 and a width of 32. The pull handle (L) has a height of 300 and a width of 59. The slim frame (V) has a height of 64 and a width of 127.</p>	<p>Technical drawings of the pull handle (L) for the Portofino CT258 series. The pull handle (L) has a height of 300 and a width of 59. The slim frame (V) has a height of 64 and a width of 127.</p>
<p>R – DOOR</p>	<p>V – SLIM FRAME</p>	<p>K – WINDOWS DK</p>	<p>H - LIFT & SLIDE</p>	<p>L - PULL HANDLES</p>

Mayfair CT259

<p>Technical drawings of the door handle (R) and slim frame (V) for the Mayfair CT259 series. The door handle (R) has a height of 54 and a width of 151. The slim frame (V) has a height of 57 and a width of 142. Both have a diameter of 50.</p>	<p>Technical drawings of the window handle (K) and lift & slide handle (H) for the Mayfair CT259 series. The window handle (K) has a height of 158 and a width of 33. The lift & slide handle (H) has a height of 162 and a width of 32. The slim frame (V) has a height of 57 and a width of 142.</p>	<p>Technical drawings of the window handle (K) and lift & slide handle (H) for the Mayfair CT259 series. The window handle (K) has a height of 158 and a width of 33. The lift & slide handle (H) has a height of 162 and a width of 32. The slim frame (V) has a height of 57 and a width of 142.</p>	<p>Technical drawings of the lift & slide handle (H) and pull handle (L) for the Mayfair CT259 series. The lift & slide handle (H) has a height of 162 and a width of 32. The pull handle (L) has a height of 300 and a width of 20. The slim frame (V) has a height of 57 and a width of 142.</p>	<p>Technical drawings of the pull handle (L) for the Mayfair CT259 series. The pull handle (L) has a height of 300 and a width of 20. The slim frame (V) has a height of 57 and a width of 142.</p>
<p>R – DOOR</p>	<p>V – SLIM FRAME</p>	<p>K – WINDOWS DK</p>	<p>H - LIFT & SLIDE</p>	<p>L - PULL HANDLES</p>

Tortona CT260

<p>Technical drawings of the door handle (R) and slim frame (V) for the Tortona CT260 series. The door handle (R) has a height of 55 and a width of 145. The slim frame (V) has a height of 63 and a width of 136. Both have a diameter of 50.</p>	<p>Technical drawings of the window handle (K) and lift & slide handle (H) for the Tortona CT260 series. The window handle (K) has a height of 152 and a width of 33. The lift & slide handle (H) has a height of 152 and a width of 32. The slim frame (V) has a height of 63 and a width of 136.</p>	<p>Technical drawings of the window handle (K) and lift & slide handle (H) for the Tortona CT260 series. The window handle (K) has a height of 152 and a width of 33. The lift & slide handle (H) has a height of 152 and a width of 32. The slim frame (V) has a height of 63 and a width of 136.</p>	<p>Technical drawings of the lift & slide handle (H) and pull handle (L) for the Tortona CT260 series. The lift & slide handle (H) has a height of 152 and a width of 32. The pull handle (L) has a height of 330 and a width of 20. The slim frame (V) has a height of 63 and a width of 136.</p>	<p>Technical drawings of the pull handle (L) for the Tortona CT260 series. The pull handle (L) has a height of 330 and a width of 20. The slim frame (V) has a height of 63 and a width of 136.</p>
<p>R – DOOR</p>	<p>V – SLIM FRAME</p>	<p>K – WINDOWS DK</p>	<p>H - LIFT & SLIDE</p>	<p>L - PULL HANDLES</p>

Tecnical Details

Lambrate CT261

<p>R – DOOR</p>	<p>V – SLIM FRAME</p>	<p>K – WINDOWS DK</p>	<p>H - LIFT & SLIDE</p>	<p>L - PULL HANDLES</p>

Citylife CT262

<p>R – DOOR</p>	<p>V – SLIM FRAME</p>	<p>K – WINDOWS DK</p>	<p>H - LIFT & SLIDE</p>	<p>L - PULL HANDLES</p>

Parioli CT263

<p>R – DOOR</p>	<p>V – SLIM FRAME</p>	<p>K – WINDOWS DK</p>	<p>H - LIFT & SLIDE</p>	<p>L - PULL HANDLES</p>

serie Contemporary

Abbott Kinney CT264

<p>R – DOOR</p>	<p>V – SLIM FRAME</p>	<p>K – WINDOWS DK</p>	<p>H - LIFT & SLIDE</p>	<p>L - PULL HANDLES</p>

Wall CT254

<p>R – DOOR</p>	<p>V – SLIM FRAME</p>	<p>K – WINDOWS DK</p>	<p>H - LIFT & SLIDE</p>	<p>L - PULL HANDLES</p>

Street CT7060

<p>R – DOOR</p>	<p>V – SLIM FRAME</p>	<p>K – WINDOWS DK</p>	<p>H - LIFT & SLIDE</p>	<p>L - PULL HANDLES</p>

Technical Details

Amalfi CT265

<p>R – DOOR</p>	<p>V – SLIM FRAME</p>	<p>K – WINDOWS DK</p>	<p>H - LIFT & SLIDE</p>	<p>L - PULL HANDLES</p>

Otta BR80

<p>R – DOOR</p>	<p>V – SLIM FRAME</p>	<p>K – WINDOWS DK</p>	<p>H - LIFT & SLIDE</p>	<p>L - PULL HANDLES</p>

Aspen BR20

<p>R – DOOR</p>	<p>V – SLIM FRAME</p>	<p>K – WINDOWS DK</p>	<p>H - LIFT & SLIDE</p>	<p>L - PULL HANDLES</p>

Truckee BR10

<p>R – DOOR</p>	<p>V – SLIM FRAME</p>	<p>K – WINDOWS DK</p>	<p>H - LIFT & SLIDE</p>	<p>L - PULL HANDLES</p>

Zermatt BR30

<p>R – DOOR</p>	<p>V – SLIM FRAME</p>	<p>K – WINDOWS DK</p>	<p>H - LIFT & SLIDE</p>	<p>L - PULL HANDLES</p>

Wanaka BR40

<p>R – DOOR</p>	<p>V – SLIM FRAME</p>	<p>K – WINDOWS DK</p>	<p>H - LIFT & SLIDE</p>	<p>L - PULL HANDLES</p>

Technical Details

Cortina BR50

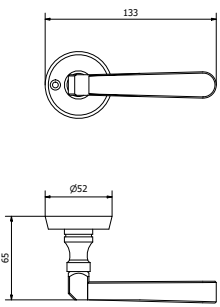
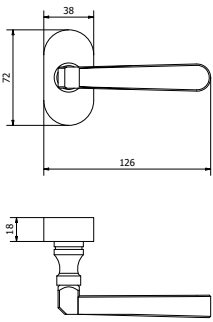
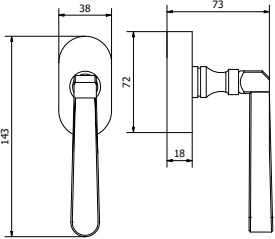
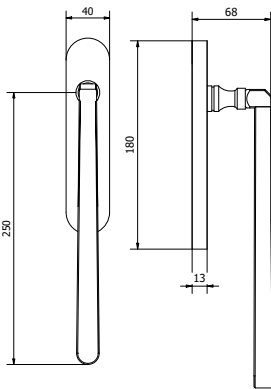
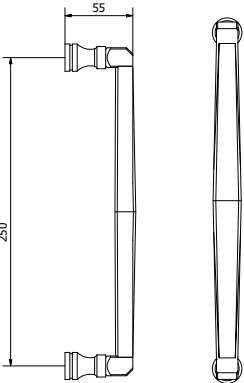
				
<p>R – DOOR</p>	<p>V – SLIM FRAME</p>	<p>K – WINDOWS DK</p>	<p>H - LIFT & SLIDE</p>	<p>L - PULL HANDLES</p>

Chamonix BR60

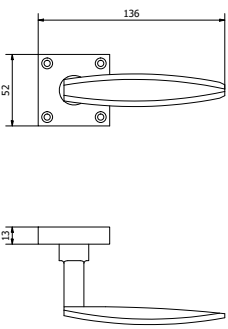
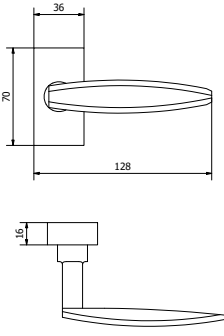
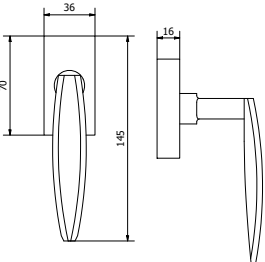
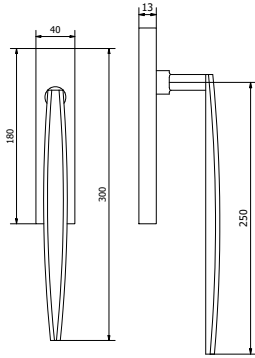
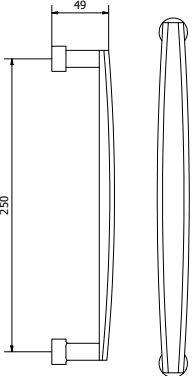
				
<p>R – DOOR</p>	<p>V – SLIM FRAME</p>	<p>K – WINDOWS DK</p>	<p>H - LIFT & SLIDE</p>	<p>L - PULL HANDLES</p>

Courmayeur BR70

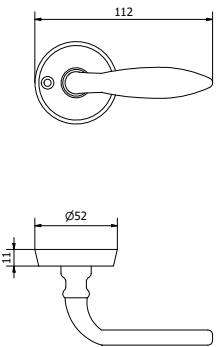
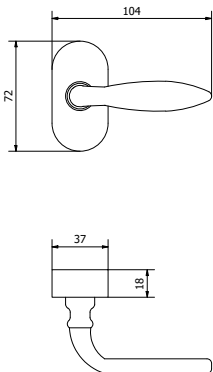
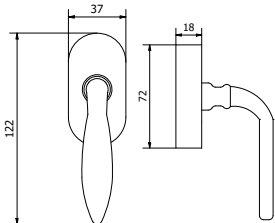
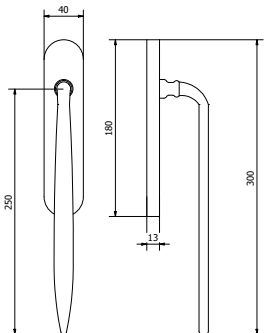
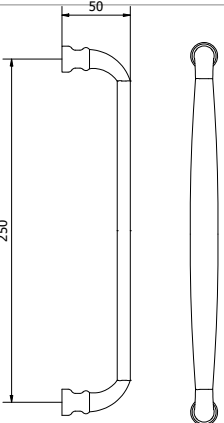
				
<p>R – DOOR</p>	<p>V – SLIM FRAME</p>	<p>K – WINDOWS DK</p>	<p>H - LIFT & SLIDE</p>	<p>L - PULL HANDLES</p>

Accessories

Cremonesi

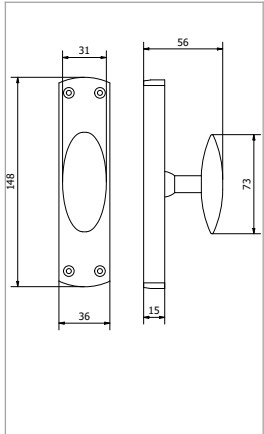
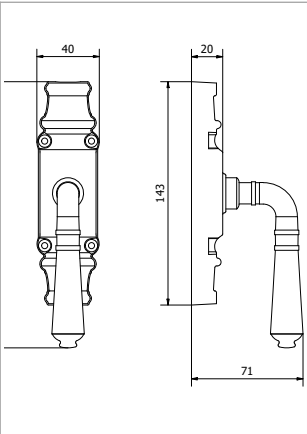
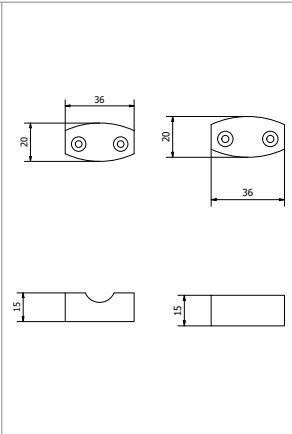
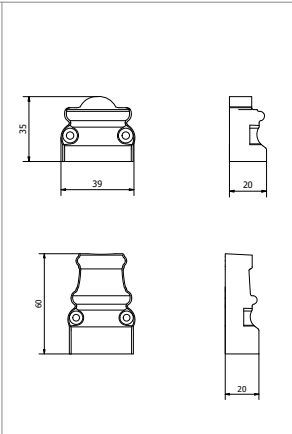
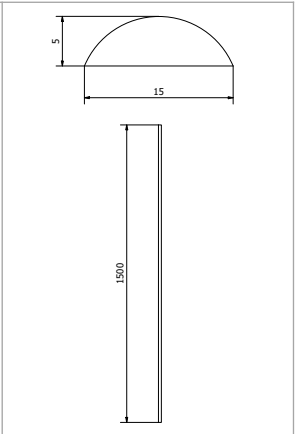
				
<p>POMOLO</p>	<p>ART</p>	<p>FINALE E PASSANTE CONTEMPORARY</p>	<p>FINALE E PASSANTE ART</p>	<p>ASTA</p>

Door Knobs

	
<p>QUADRO</p>	<p>TONDO</p>

Plate Yale

	
<p>QUADRO</p>	<p>TONDO</p>



Finishes

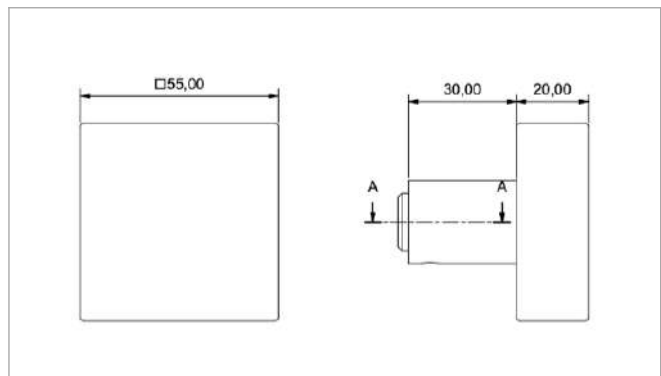
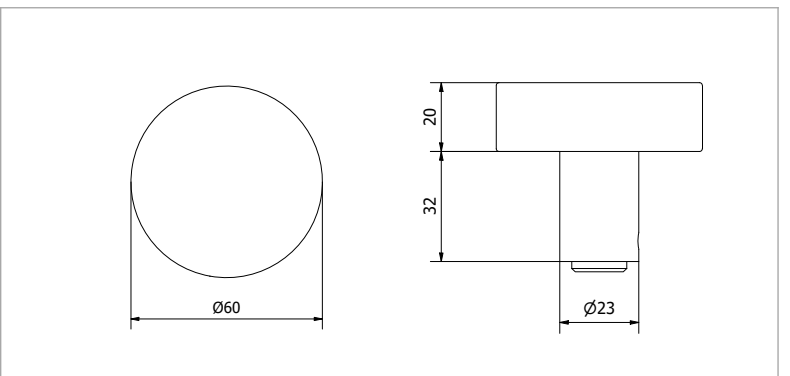
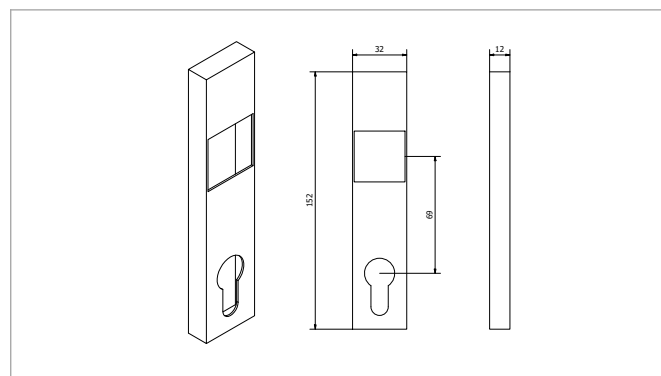
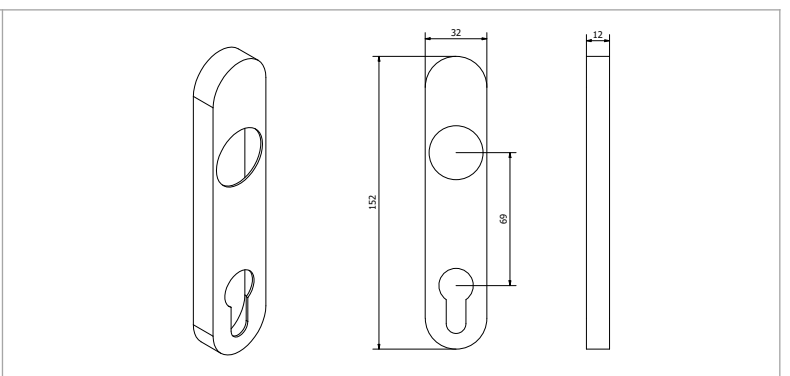

OSO

OTTONE SATINATO OPACO VERNICIATO
MATT BRASS



ON

OTTONE NATURALE
NATURAL BRASS



OLV

ORO LUCIDO VERNICIATO
POLISHED GOLD



NST

NERO SOFT TOUCH
SOFT TOUCH MATT BLACK



NO

NERO OPACO
MATT BLACK



CS

CROMO OPACO
SATIN CHROME



CR

CROMO LUCIDO
POLISHED CHROME



OBGV

BRONZO GRAFFIATO VERNICIATO
SATIN BBRONZE



BO

BRONZO OPACO
MATT BRONZE



BA

BRONZO ANTICATO
ANCIENT BRONZE



FA

FERRO ANTICATO
ANCIENT IRON

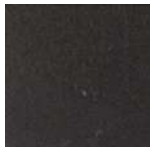

BLK

BRONZO NERO
BLACK BRONZE



BN

BRONZO NATURALE
NATURAL BRONZE



BN

BRONZO FERRO ANTICO
GREY BRONZE



BB

BRONZO BIANCO
WHITE BRONZE



VI

BRONZO VERDE
GREEN BRONZE

FINITURA PVD AGGIUNTIVA : APPLICABILE AD OGNI FINITURA.
IL PVD è UN TRATTAMENTO GALVANICO AD ALTA RESISTENZA PER MANTENERE LA FINITURA NEL TEMPO INVARIATA.

ADDITIONAL PVD FINISH: APPLICABLE TO ANY FINISH. PVD IS A HIGH RESISTANCE GALVANIC TREATMENT TO KEEP THE FINISH UNCHANGED OVER TIME.



Diamo futuro a materiali carichi di storia

Le Fabric dà la possibilità di customizzare i prodotti che produce sia in tema di materiali (**ottone, bronzo, ferro, rame e acciaio inox**) sia nella scelta della finitura e colore in base al proprio gusto.

Le maniglie fra infinite ispirazioni e personalizzazioni

Ogni elemento rende unico non solo la maniglia, il maniglione o il pomolo realizzato da Le Fabric, ma anche la porta, la finestra o il mobile al quale sono destinati. dal linguaggio *industrial*, moderno, lineare e dallo stile vintage è scaturita l'ispirazione per una collezione che fonde memoria e rigore espressivo con bellezza e concretezza.

le maniglie *custom* possono essere realizzate in ferro, ottone, bronzo, peltro, rame e acciaio inox: materiali che, grazie alle caratteristiche di fusione, donano un aspetto unico e inimitabile a ogni singola maniglia.

A material is not a limit, but an infinite inspiration

Le Fabric gives you the possibility to customise our products according to your taste, both in terms of materials (brass, bronze, iron and stainless steel) and in the choice of finishes and colours.

The brilliance of brass

Say the word **brass**, and you think of doorhandles. Its malleability and ductility, combined with its resilience, have found it success in many areas, from the production of coins to that of sought-after accessories for furniture, doors and windows. It is also a material that, above all, “sounds good”, and for this reason it is used for the production of instruments such as trumpets and saxofones, which are known as brass instruments.

The charme of bronze

Bronze is a noble metal, used for creating valuable objects and pieces of art. Starting from **red bronze** and **white bronze**, it is possible to obtain different finishes that give this material diverse appearances, varying from natural bronze, to imperial green and antiqued bronze. What all of these finishes have in common is their level of resistance, including those exposed to external agents, and a fascinating quality that only increases over time.

The resistance of stainless steel

Stainless steel is a durable material, resistant to corrosion, acid and abrasion. It does not rust, thanks to the components of the alloy that forms it, chrome and nickel, which form an invisible, passive layer. It is the ultimate hygienic material, making it perfect for the production of doorhandles, not only for its sought-after appearance, but also because it is resistant to bacteria.

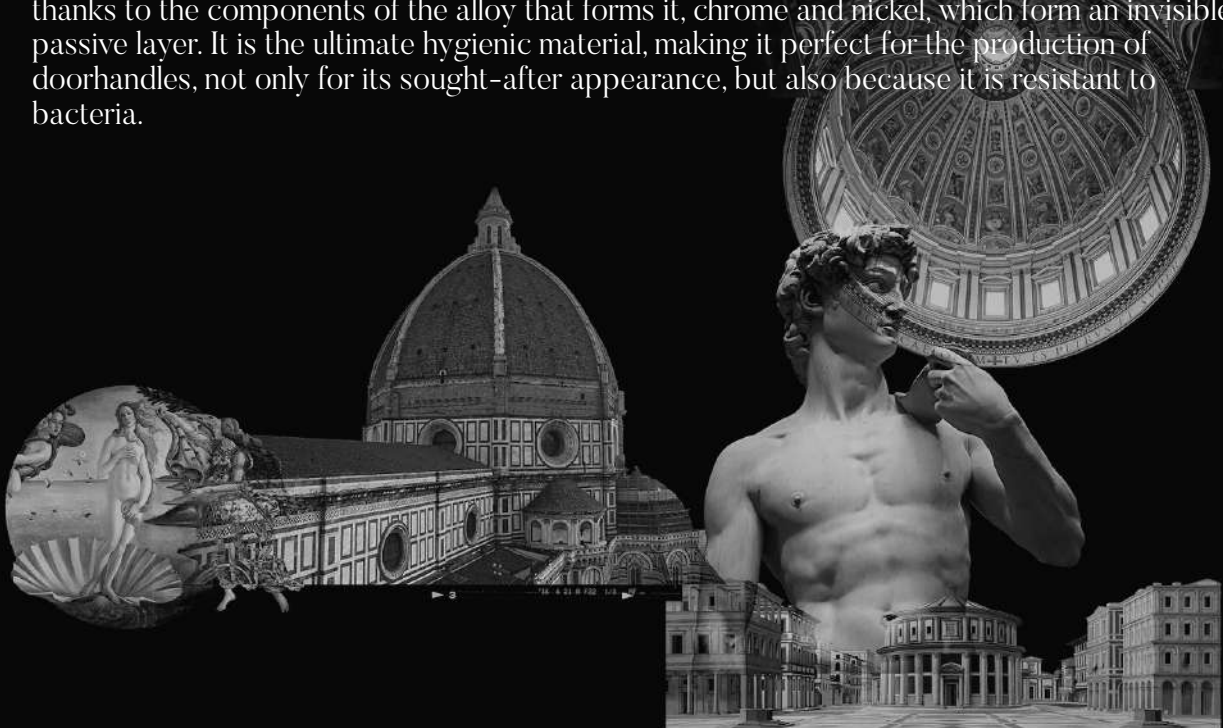

CREDITS

↓

Albertini Italian Windows & Doors, LLC

Apexfine by Ponzio srl

Rocchi Piubello Architettura

Arch Paolo Richelli

Studio C16 Officine

Le immagini delle location presenti nel catalogo sono rappresentative ed esprimono alcune suggestioni dei nostri prodotti.

CONTACT

Headquarter



Verona, Italy

Via Salisburgo 5 - 36137

info@lefabric.com

+39.045.50.0051

Showroom



Verona

Milano

Moscow

Los Angeles

Miami

Hanghou

London

Every project is a challenge we face with enthusiasm, consulting with architects and designers, committing ourselves to furthering the project and making it the centrepiece of our next production.

Ogni progetto è una sfida che accogliamo con entusiasmo e che rilanciamo ad architetti e designer, impegnandoci a promuoverne i progetti e a renderli protagonisti delle nostre prossime pubblicazioni.