



Tenditore a scomparsa tipo TN401 TN403 TN404

Hidden wardrobe adjuster TN401 TN403 TN404 type

NORMALMENTE UTILIZZATI SU PANNELLI DI TAMBURATO. SPESSORE MINIMO 18-20 A SECONDA DELLO SPESSORE DELLA COPERTURA VEDI FIG. 1.

1. REGOLAZIONE SINGOLA E DOPPIA. INTERASSE MIN. 1200 MAX. 2800.

NORMALLY USED ON HOLLOW WOOD PANELS. MINIMUM THICKNESS 18-20, DEPENDING ON THE THICKNESS OF THE COVER, SEE FIG. 1 SINGLE AND DOUBLE ADJUSTMENT. CENTRE DISTANCE: MINIMUM 1200 MAXIMUM 2800



1 pz asta acciaio tenditore 1 pcs adjuster steel bar
2 pz bussole zama esterne 2 pcs external zamak housings

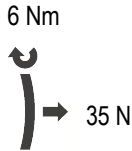
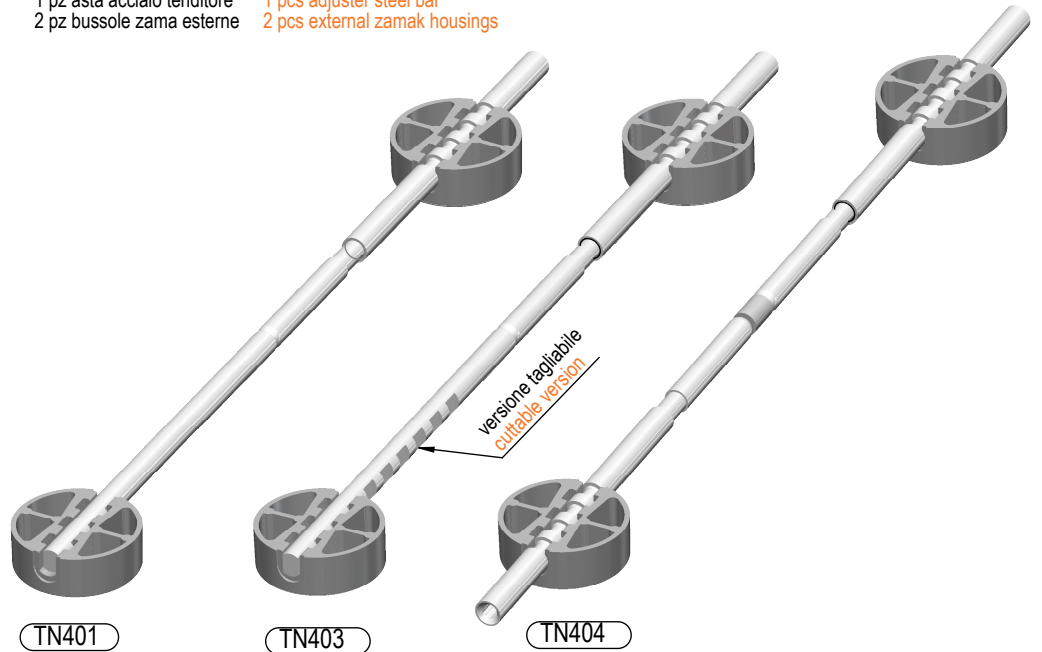

test indicativi su pannello agglomerato 2500x400x20
indicative test on chipboard panel 2500x400x20

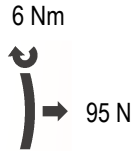

test indicativi su pannello agglomerato 2500x400x28
indicative test on chipboard panel 2500x400x28

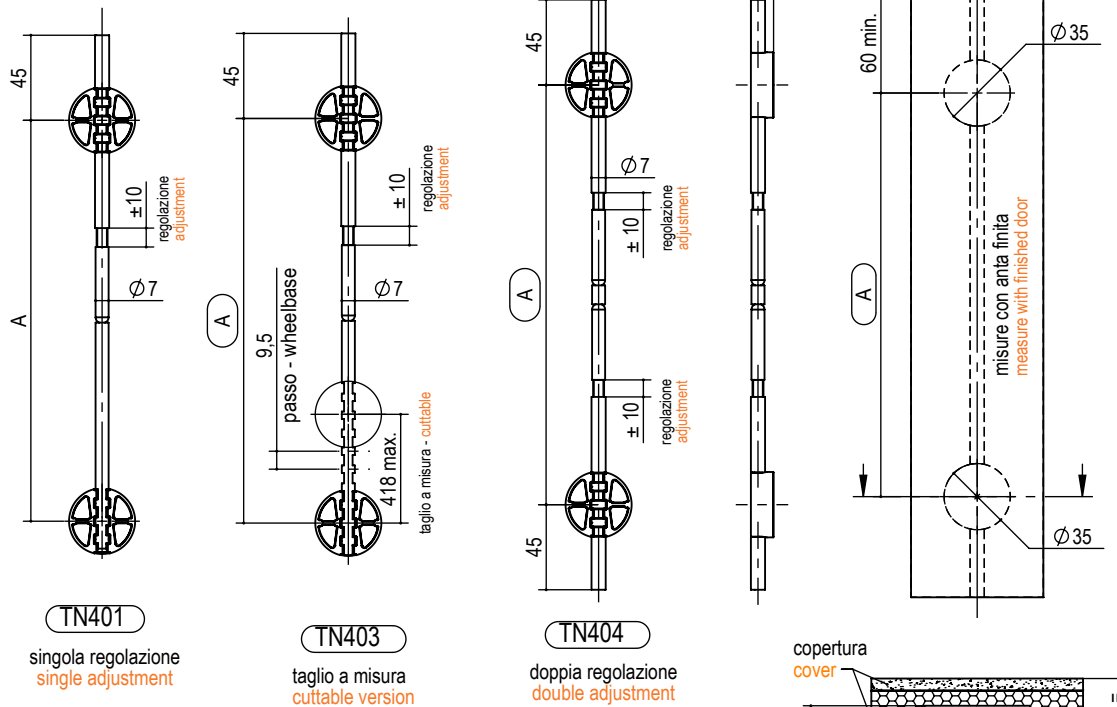

TN401
singola regolazione
single adjustment

TN403
taglio a misura
cuttable version

TN404
doppia regolazione
double adjustment

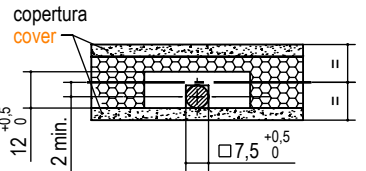

tipo type	misura measure	A	finitura finishing	Imballo su bancale Packed on pallet		
				kg/pz	kg/box	
TN401. TN403. TN404.	1700.	1700	00 grezzo - raw minimo ordine 100 pz - MOQ 100 pcs misura speciale minimo ordine 300 pz - special measure 300 pcs MOQ	kg/pz	kg/box	
	1900.	1900			25pz	
	2010.	2010			100pz	
	2300.	2300			14,5	58
	2450.	2450			0,63	63
	2610.	2610			0,66	66
	2760.	2760			0,75	75
2800.	2800	0,79	79			
			0,84	84		
			0,88	88		
			0,9	90		