

# AC-351

Staffa di rinvio albero zincato quadro

SERIE SALIENT

DIMENSIONI

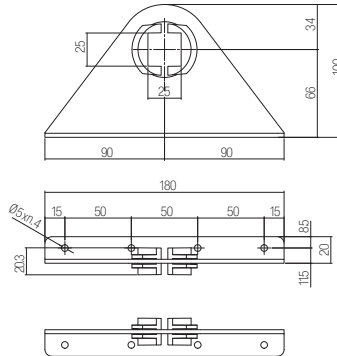

CODICE	ARTICOLO	CONFEZIONE	PESO
GST005SQNOG00	AC-351	1 pcs.	0,30 kg

# AC-300 / AC-305 / AC-307

Staffa di supporto zincata

SERIE SALIENT

DIMENSIONI

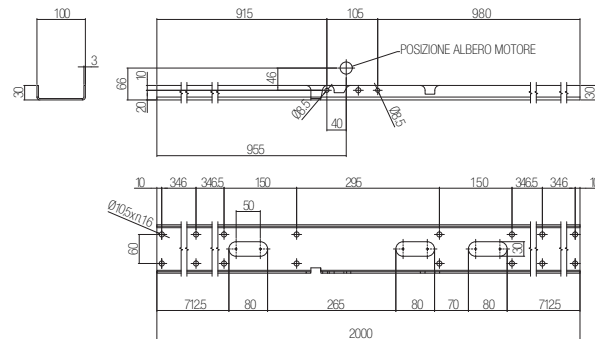

CODICE	ARTICOLO	CONFEZIONE	PESO
GST006ASNO600	AC-300 - 615 mm	1 pcs.	2 kg
GST007ASNOG00	AC-305 - 1250 mm	1 pcs.	4,1 kg
GST008ASNOG00	AC-307 - 2000 mm	1 pcs.	6,5 kg

