

CARATTERISTICHE

Sistema scorrevole per antine di legno.

Semplice montaggio senza l'ausilio di utensili, viti o colla.

Bloccaggio rapido mezzo rotazione levette.

Regolazione manuale verticale.

Disponibile con chiusura decelerata.

L'alta qualità dei materiali, la cura del design e la componentistica (viteria inox e galvanica speciale), lo rendono adatto ad essere utilizzato per l'arredo navale o per ambienti salmastri.

ISTRUZIONI PER IL MONTAGGIO

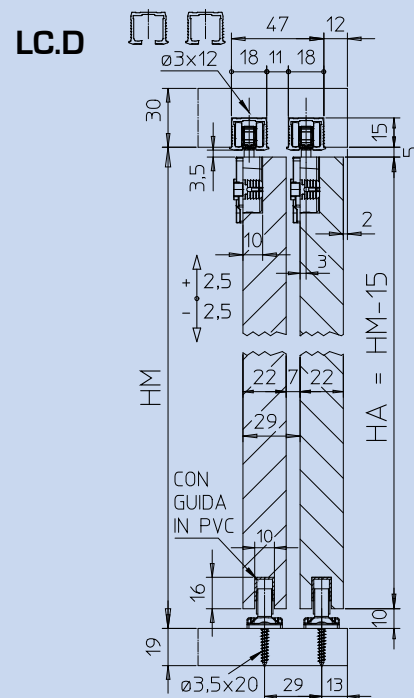
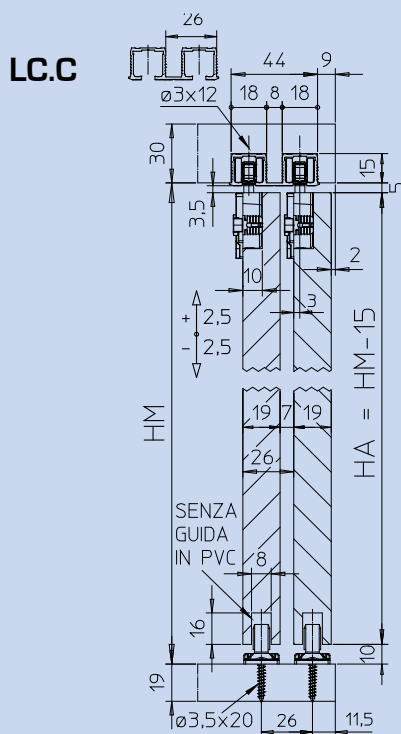
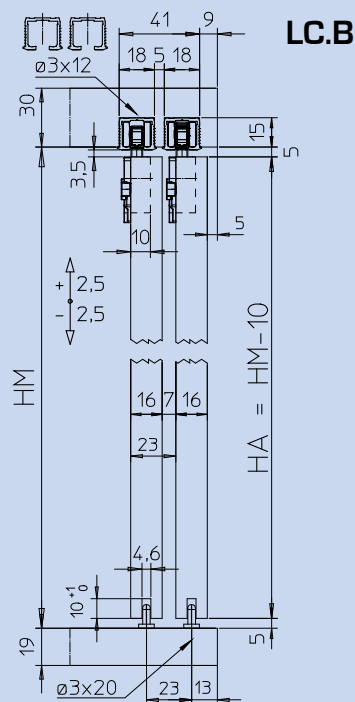
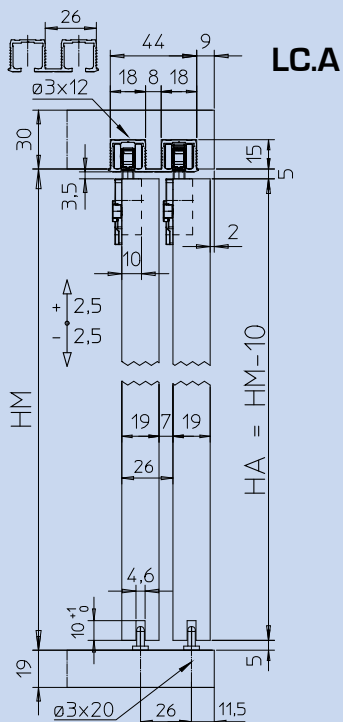

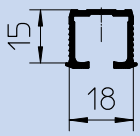

Profilo in alluminio singolo da incasso, da avvitare o incollare; fori svasati, vite TSP Ø 3 ARGENTO

CODICE 1003235101A

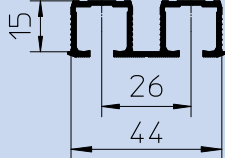

Profilo in alluminio doppio da incasso, passo 26, da avvitare o incollare; fori svasati, vite TSP Ø 3 ARGENTO

CODICE 1003235102A

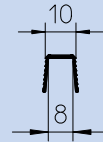

Profilo inferiore in plastica NERO, per guida inferiore cod.10032035006

CODICE 1003235141N



Carrello con clip

CODICE 10032035016



Fermo fine corsa, con regolazione forza

CODICE 10032035002



Carrello decelerato con attivatore

COD. 10032035015 Kg 10



Guida inferiore per legno con base zama (Optional)

CODICE 10032035006



Guida inferiore da avvitare (di serie)

CODICE 1001005



Guida inferiore a pressione

CODICE 1001004



Dima di foratura Ø 10 interasse 52 mm

CODICE 10032035010



Carrello Colibri decelerato con clip e attivatore

COD. 10032035028L Kg 10

ESEMPIO DI MONTAGGIO
KIT SENZA DECELERATORE

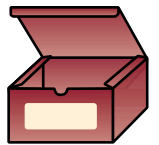
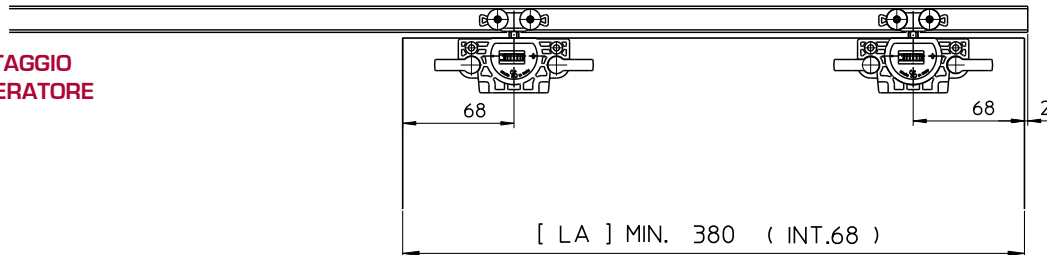

CODICE
10032035301

ESEMPIO DI MONTAGGIO
KIT CON UN DECELERATORE

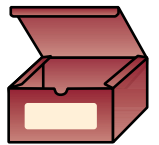
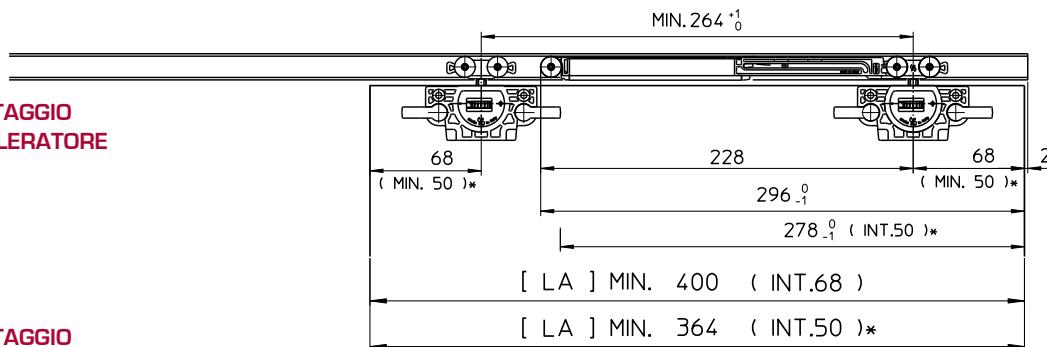

CODICE
10032035308

ESEMPIO DI MONTAGGIO
KIT CON DUE DECELERATORI

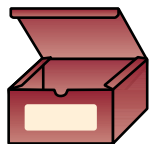
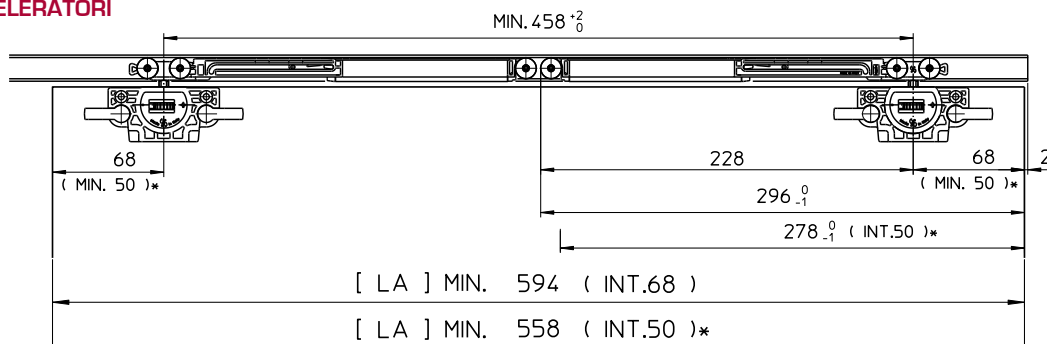

CODICE
10032035309

SCHEMA FORATURA CLIP RAPIDA

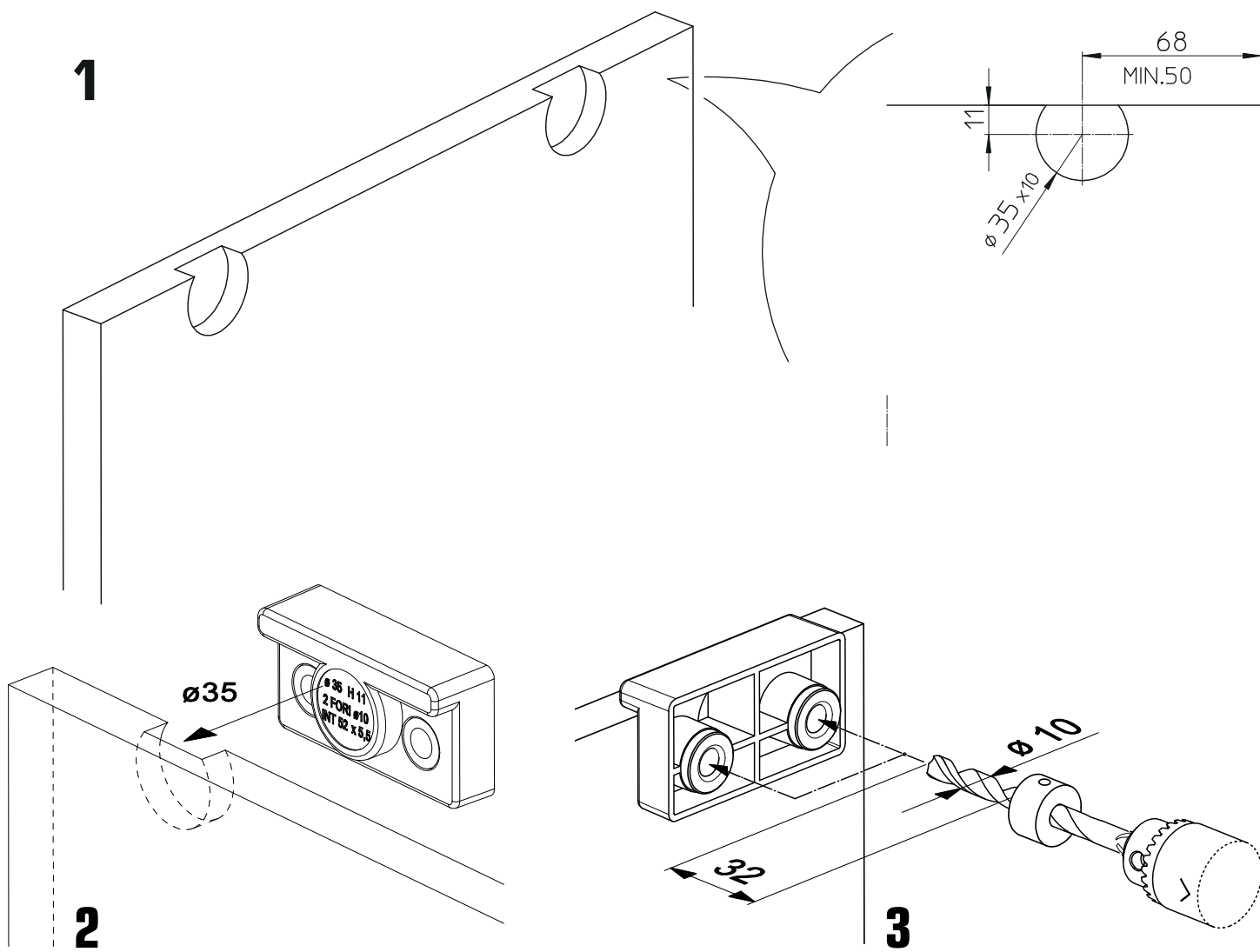

Inserimento carrelli e fermi con binario pre fissato, valido per tutti i tipi di profili

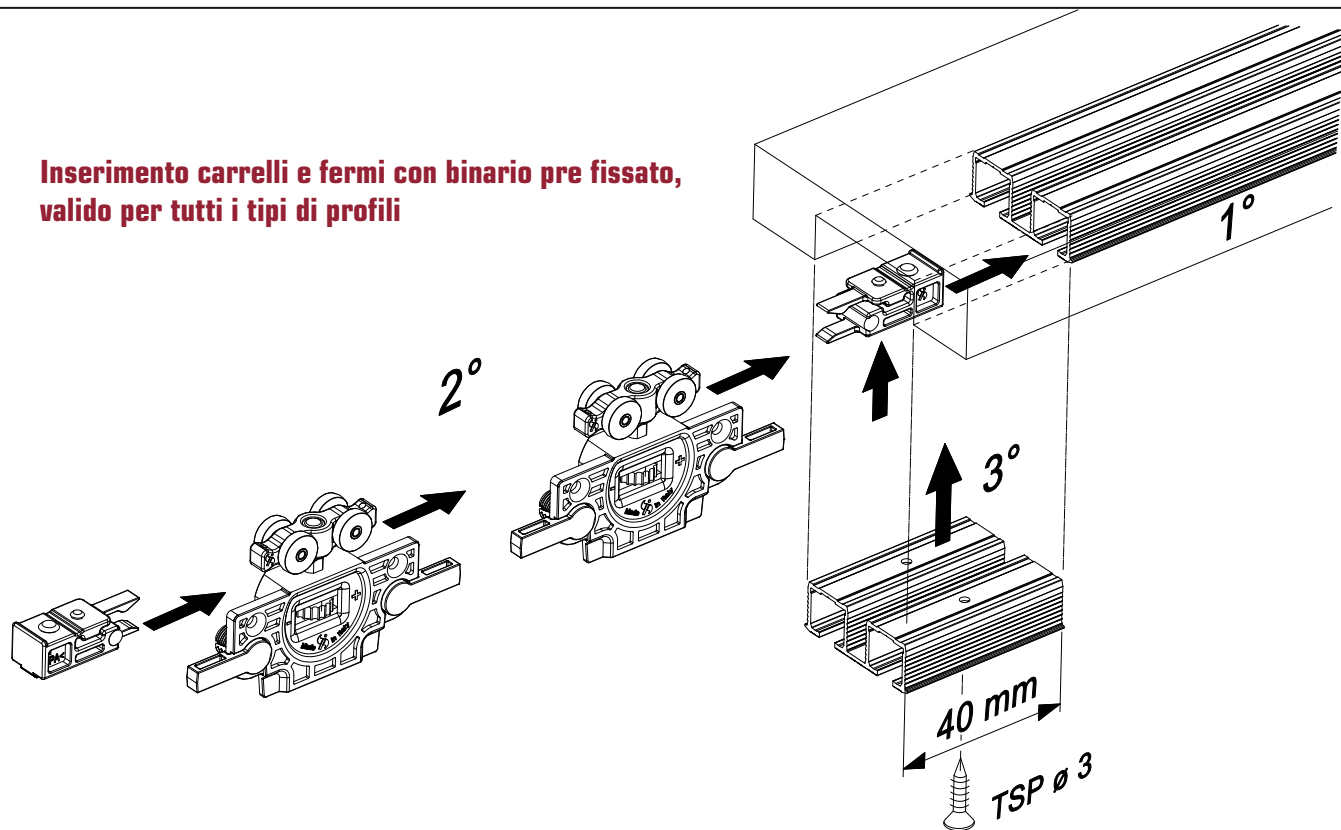

ISTRUZIONI MONTAGGIO ANTA LEGNO CON CLIP RAPIDA

**Montaggio anta
Per guida inferiore
composta**

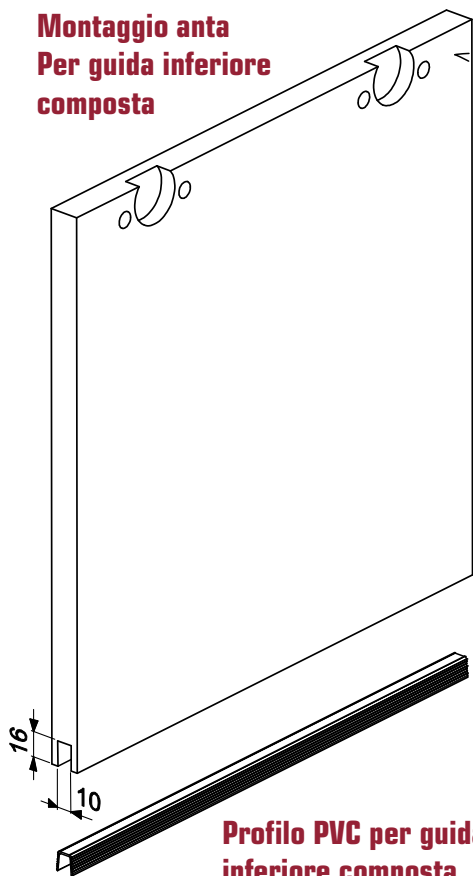

**Profilo PVC per guida
inferiore composta**

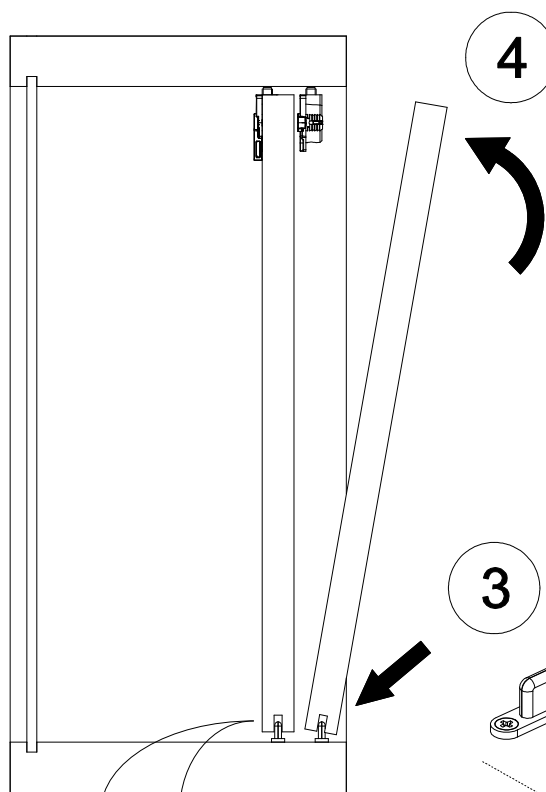
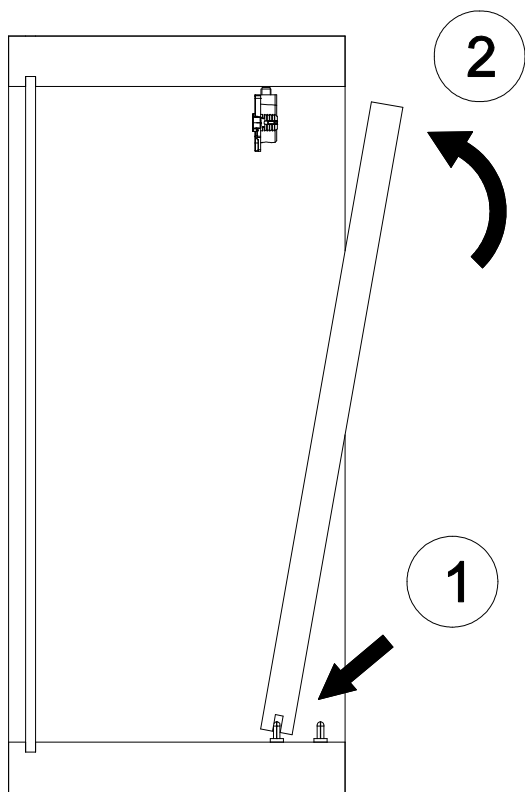
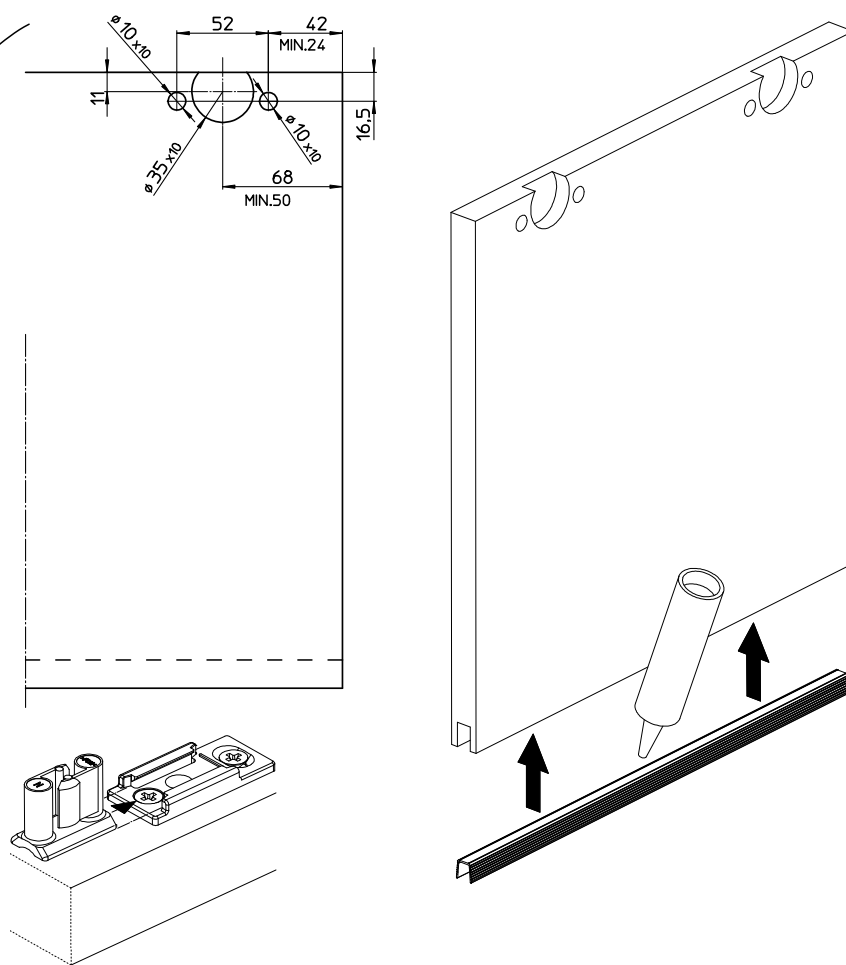

Per guida inferiore "piccola" fissa

