

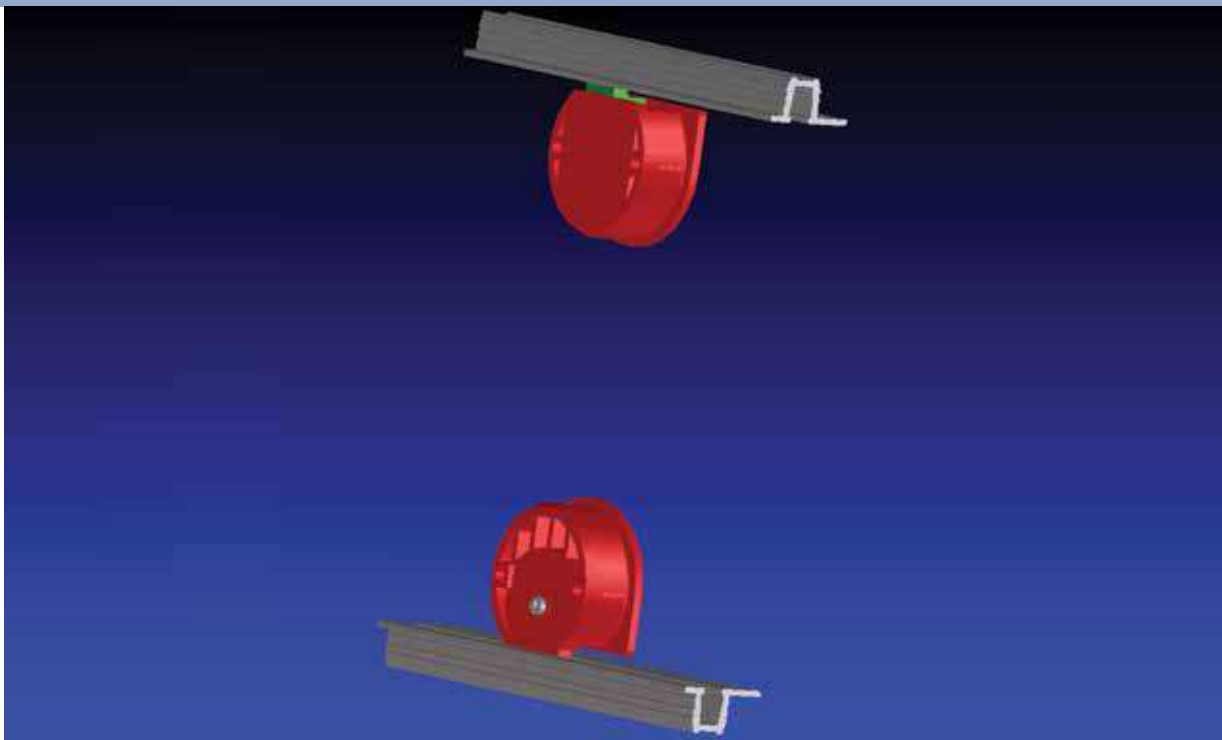

### CARATTERISTICHE

- 1) Ruota bicomponente per una migliore silenziosità
- 2) Fissaggio dei carrelli senza viti
- 3) Semplice regolazione
- 4) Perno lubrificato per una migliore scorrevolezza

### ISTRUZIONI PER IL MONTAGGIO



Kit FALCO

CODICE  
1003503

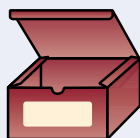

- 2 carrelli inferiori
- 2 carrelli superiori
- 2 fermi fine corsa

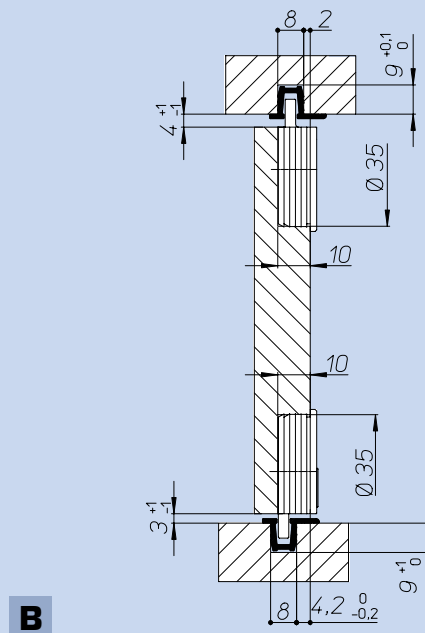
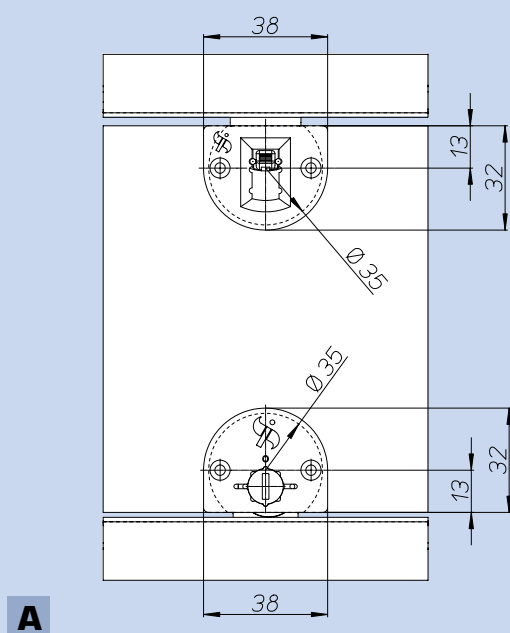

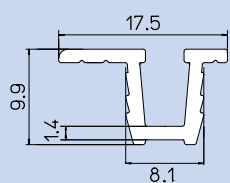

**Profilo in plastica**

<b>GRIGIO</b>	CODICE 1003501G
<b>BIANCO</b>	CODICE 1003501B
<b>MARRONE</b>	CODICE 1003501M
<b>NERO</b>	CODICE 1003501N

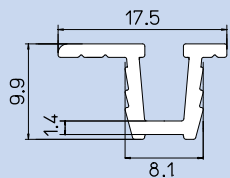
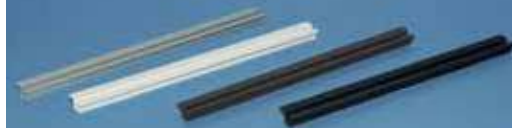

**Profilo in plastica**

<b>FRASSINO</b>	CODICE 1003501F
<b>CILIEGIO</b>	CODICE 1003501C
<b>DOUGLAS</b>	CODICE 1003501D

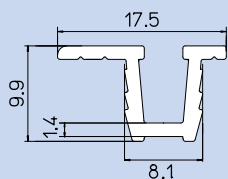

**Profilo in alluminio ossidato**

<b>ARGENTO</b>	CODICE 1004501A
<b>BRONZO</b>	CODICE 1004501B
<b>NERO</b>	CODICE 1004501N

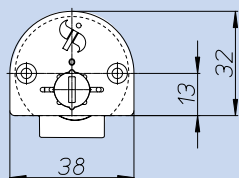
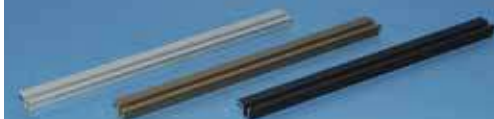

**Carrello inferiore con regolazione**

CODICE 1003504

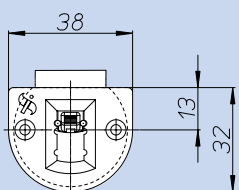

**Carrello superiore con regolazione**

CODICE 1003505

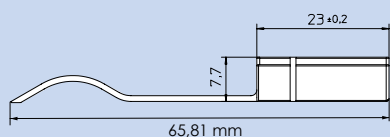

**Fermo fine corsa**

CODICE 1003508





## CARATTERISTICHE

## ISTRUZIONI PER IL MONTAGGIO

- 1) Semplice regolazione
- 2) Ruota tornita
- 3) Perno lubrificato per una migliore scorrevolezza

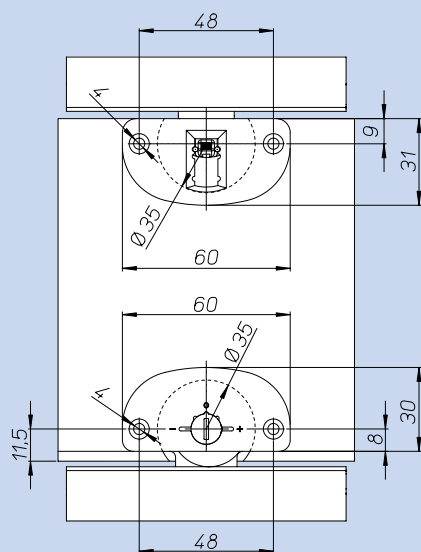

**A**

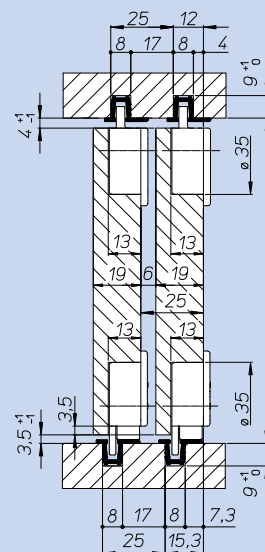

**B**

Kit VOLPE  
RUOTA TORNITA PIANA  
CODICE  
1004511P

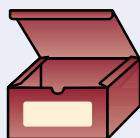

- 2 carrelli inferiori
- 2 carrelli superiori
- 2 fermi fine corsa

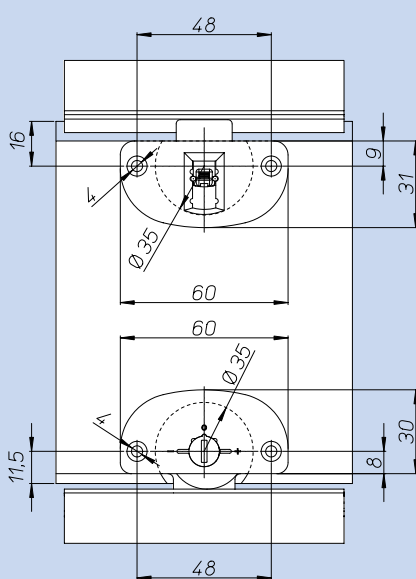

**C**

*"n.b. solo su richiesta"*

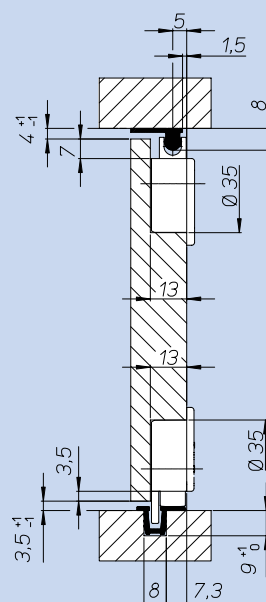

**D**

*"n.b. solo su richiesta"*

# VOLPE 30 KG RUOTA TORNITA PIANA Scorrevoli per Mobili

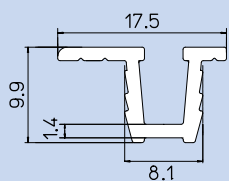

Profilo in plastica

<b>GRIGIO</b>	CODICE 1003501G
<b>BIANCO</b>	CODICE 1003501B
<b>MARRONE</b>	CODICE 1003501M
<b>NERO</b>	CODICE 1003501N

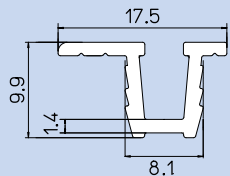
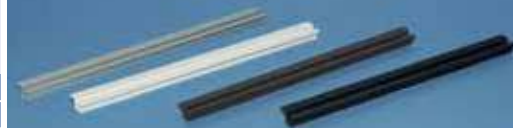

Profilo in plastica

<b>FRASSINO</b>	CODICE 1003501F
<b>CILIEGIO</b>	CODICE 1003501C
<b>DOUGLAS</b>	CODICE 1003501D

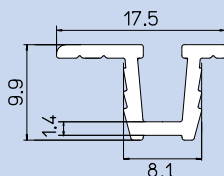

Profilo in alluminio ossidato

<b>ARGENTO</b>	CODICE 1004501A
<b>BRONZO</b>	CODICE 1004501B
<b>NERO</b>	CODICE 1004501N

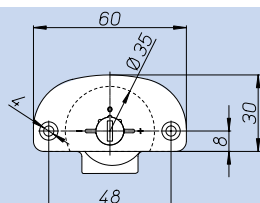

Carrello inferiore con regolazione con ruota tornita

CODICE 1004510

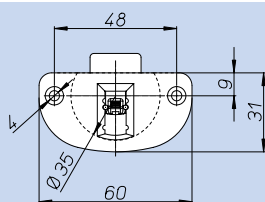

Carrello superiore con regolazione

CODICE 1004505

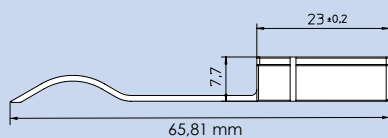

Fermo fine corsa

CODICE 1003508





### CARATTERISTICHE

- 1) Semplice regolazione
- 2) Cuscinetto rettificato rivestito in POM 100

### ISTRUZIONI PER IL MONTAGGIO

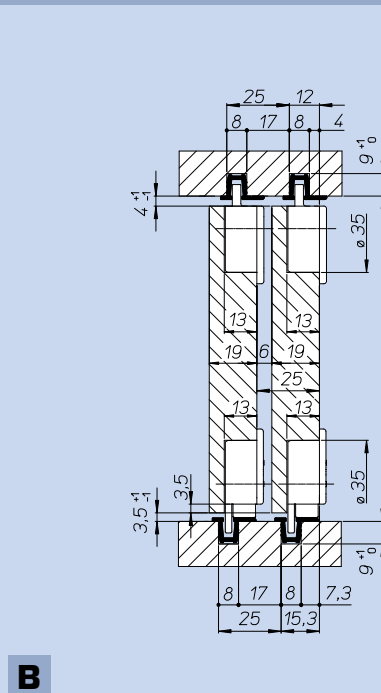
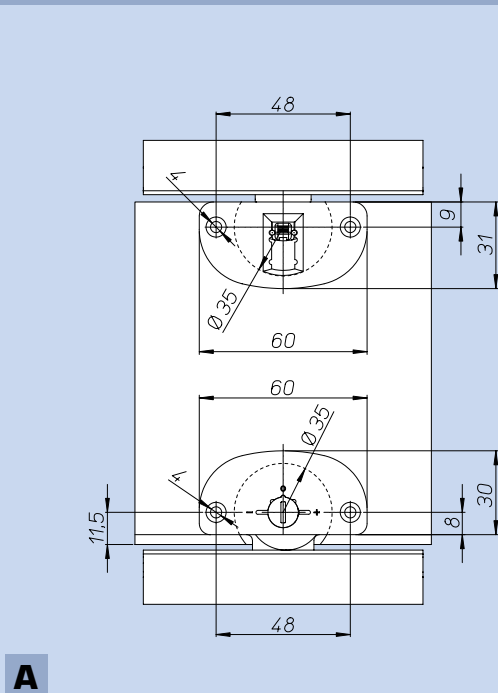

Kit VOLPE  
CUSCINETTO PIANO  
CODICE  
1004503P

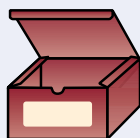

- 2 carrelli inferiori
- 2 carrelli superiori
- 2 fermi fine corsa

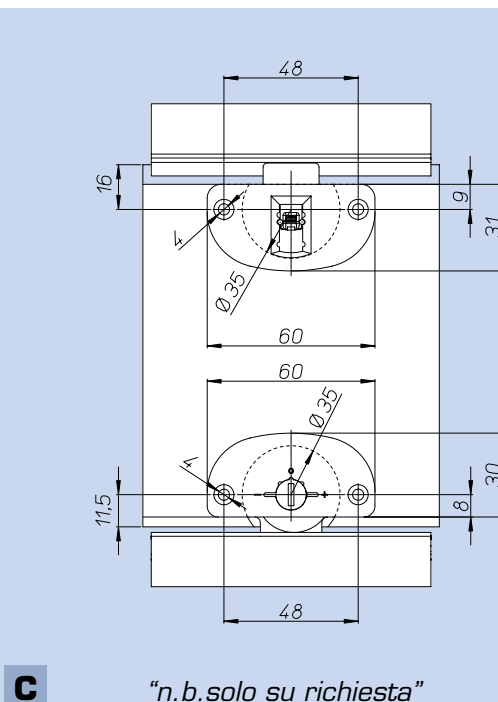

*"n.b. solo su richiesta"*

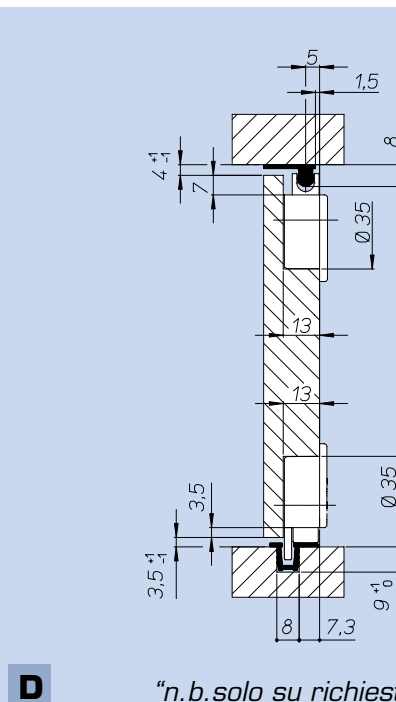

*"n.b. solo su richiesta"*

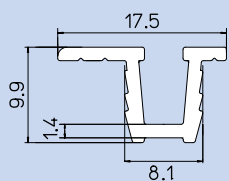

Profilo in plastica

<b>GRIGIO</b>	CODICE 1003501G
<b>BIANCO</b>	CODICE 1003501B
<b>MARRONE</b>	CODICE 1003501M
<b>NERO</b>	CODICE 1003501N

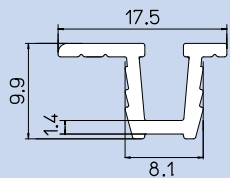
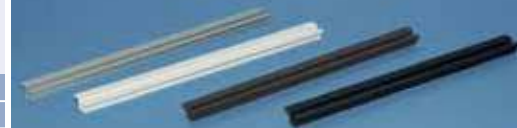

Profilo in plastica

<b>FRASSINO</b>	CODICE 1003501F
<b>CILIEGIO</b>	CODICE 1003501C
<b>DOUGLAS</b>	CODICE 1003501D

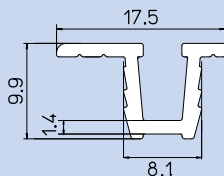

Profilo in alluminio ossidato

<b>ARGENTO</b>	CODICE 1004501A
<b>BRONZO</b>	CODICE 1004501B
<b>NERO</b>	CODICE 1004501N

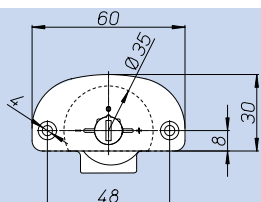

Carrello inferiore con regolazione con cuscinetto rettificato

CODICE 1004504

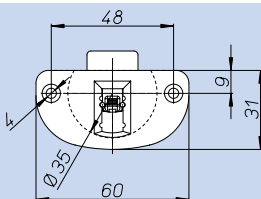

Carrello superiore con regolazione

CODICE 1004505

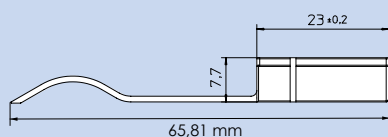

Fermo fine corsa

CODICE 1003508





## CARATTERISTICHE

1) Il kit polifunzionale che, grazie alla possibilità di sostituire il pattino superiore nel corpo carrello, consente di essere utilizzato con profili diversi, adattandosi a molteplici soluzioni.

2) Semplice regolazione

3) Ruota tornita

4) Perno lubrificato per una migliore scorrevolezza

## ISTRUZIONI PER IL MONTAGGIO

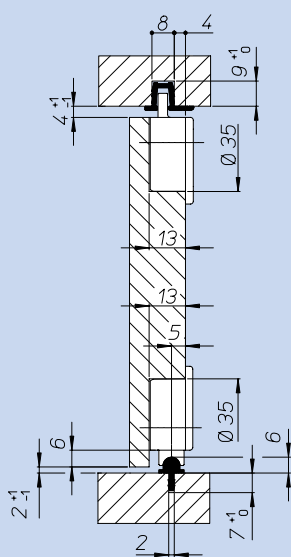

**A**

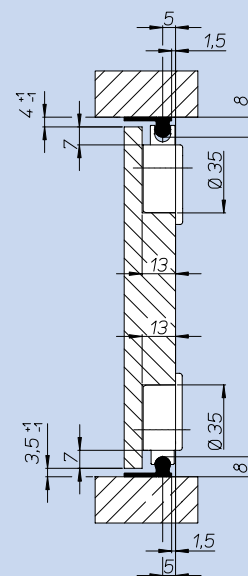

**B**

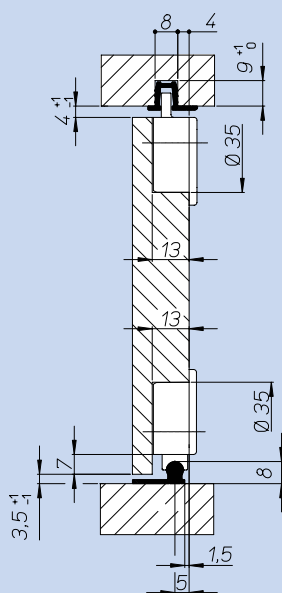

**C**

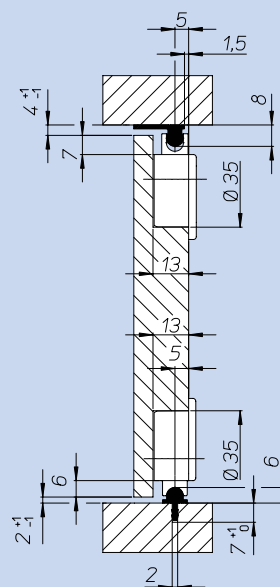

**D**

Kit VOLPE  
RUOTA GOLA  
CODICE  
1004512G2

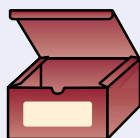

2 carrelli inferiori

2 carrelli superiori

2 fermi fine corsa

2 pattini superiori femmina

2 pattini superiori maschio

# VOLPE 30 KG RUOTA TORNITA GOLA Scorrevoli per Mobili

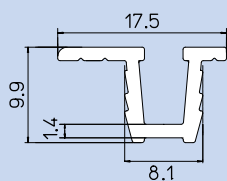

Profilo in plastica

GRIGIO	CODICE 1003501G
BIANCO	CODICE 1003501B
MARRONE	CODICE 1003501M
NERO	CODICE 1003501N

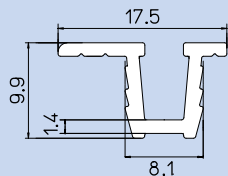

Profilo in plastica

FRASSINO	CODICE 1003501F
CILIEGIO	CODICE 1003501C
DOUGLAS	CODICE 1003501D

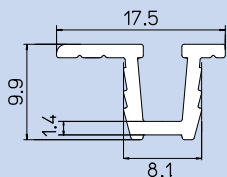

Profilo in alluminio ossidato

ARGENTO	CODICE 1004501A
BRONZO	CODICE 1004501B
NERO	CODICE 1004501N

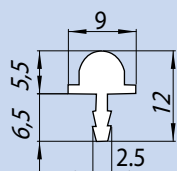
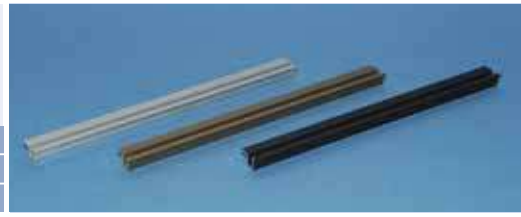

Profilo in alluminio ossidato

ARGENTO	CODICE 1004001A
BRONZO	CODICE 1004001B
NERO	CODICE 1004001N

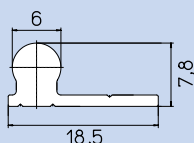

Profilo in alluminio ossidato, fori svasati ogni 30 cm, vite TSP Ø 3

ARGENTO	CODICE 1004502A
BRONZO	CODICE 1004502B
NERO	CODICE 1004502N

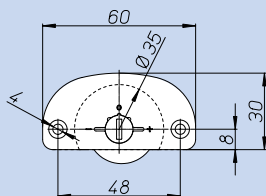

Carrello inferiore con regolazione con ruota tornita

CODICE 1004509

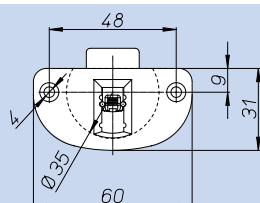

Carrello superiore con regolazione pattino maschio

CODICE 1004505

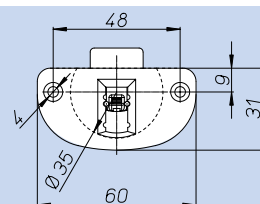

Carrello superiore con regolazione pattino femmina

CODICE 1004506

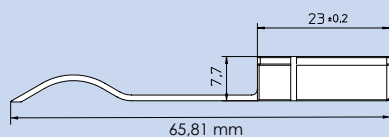

Fermo fine corsa

CODICE 1003508







### CARATTERISTICHE

1) Il kit polifunzionale che, grazie alla possibilità di sostituire il pattino superiore nel corpo carrello, consente di essere utilizzato con profili diversi, adattandosi a molteplici soluzioni

2) Semplice regolazione

3) Cuscinetto rettificato rivestito in POM 100

### ISTRUZIONI PER IL MONTAGGIO

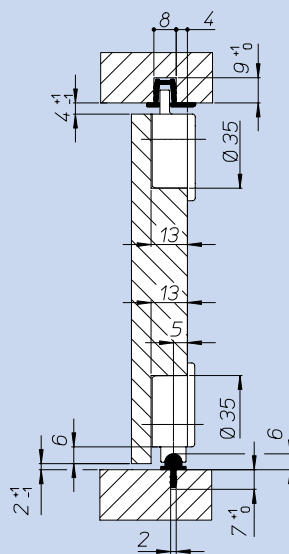

**A**

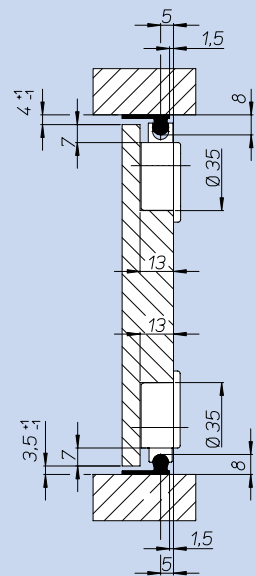

**B**

Kit VOLPE  
CUSCINETTO GOLA  
CODICE  
1004503G2

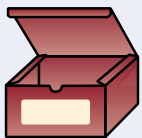

2 carrelli inferiori

2 carrelli superiori

2 fermi fine corsa

2 pattini superiori femmina

2 pattini superiori maschio

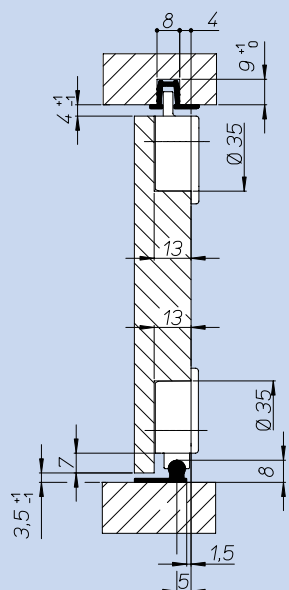

**C**

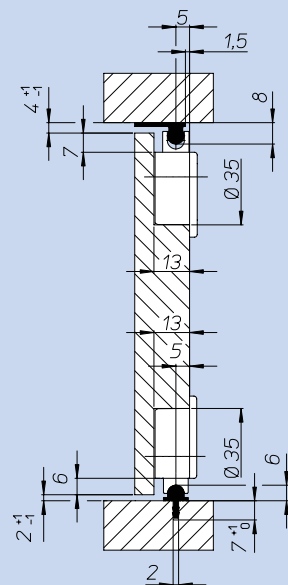

**D**

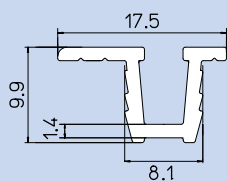

Profilo in plastica

GRIGIO	CODICE 1003501G
BIANCO	CODICE 1003501B
MARRONE	CODICE 1003501M
NERO	CODICE 1003501N

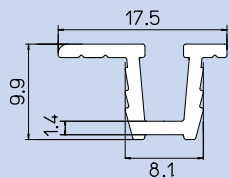
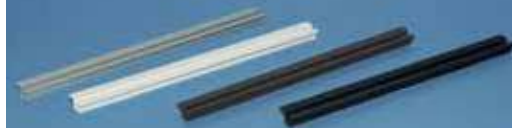

Profilo in plastica

FRASSINO	CODICE 1003501F
CILIEGIO	CODICE 1003501C
DOUGLAS	CODICE 1003501D

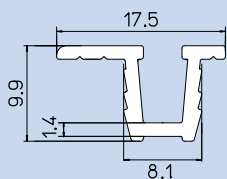

Profilo in alluminio ossidato

ARGENTO	CODICE 1004501A
BRONZO	CODICE 1004501B
NERO	CODICE 1004501N

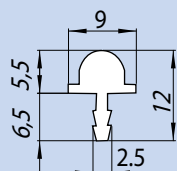

Profilo in alluminio ossidato

ARGENTO	CODICE 1004001A
BRONZO	CODICE 1004001B
NERO	CODICE 1004001N

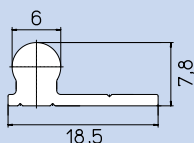

Profilo in alluminio ossidato, fori svasati ogni 30 cm, vite TSP Ø 3

ARGENTO	CODICE 1004502A
BRONZO	CODICE 1004502B
NERO	CODICE 1004502N

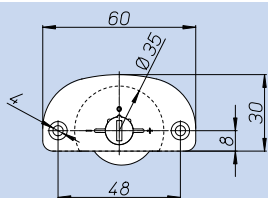

Carrello inferiore con regolazione con cuscinetto rettificato

CODICE 1004507

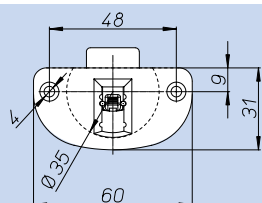

Carrello superiore con regolazione pattino maschio

CODICE 1004505

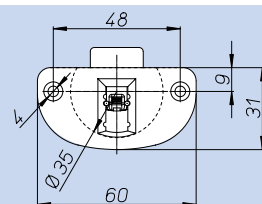

Carrello superiore con regolazione pattino femmina

CODICE 1004506

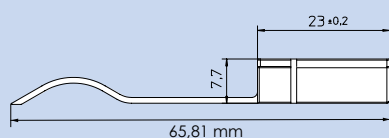

Fermo fine corsa

CODICE 1003508

