

RUOTE GOLA TONDA DIAMETRO 20mm E 8mm
 HALF-ROUND GROOVE WHEELS DIAMETER 20mm AND 8mm

VA1403

- IT Ruota gola tonda con supporto interno a saldare
- EN Half-round groove wheel with internal support to weld
- DE Runde-Rille Laufrollen mit Innenstützplatte zu befestigen
- FR Roue gorge ronde avec support intérieur à souder
- ES Rueda canal redondo con soporte interior para soldar

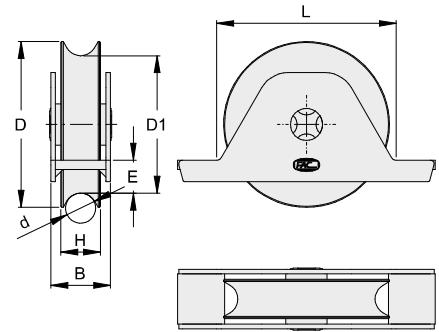

CODE	ARTICLE	D	D1	d	B	H	E	L	CAPACITY KG	PACK INFO	
ZINCATO / GALVANIZED											
⊙ x1	VA1403.090	107/20	90	72	20	33	24	17	97	200	6, 6,1
	VA1403.100	723.100/20	100	82	20	33	24	20	110	250	4, 5,4
	VA1403.120.2	207/20	120	101	20	38	25	23	130	400	2, 4,4
⊙ x2	VA1403.140.2	723.140	140	121	20	38	25	27	152	420	4, 12,4
	VA1403.160.2	723.160	160	140	20	42	30	32	175	450	4, 19,8
	VA1403.200.2	723.200	200	178.5	20	50	32	42	216	700	2, 17,0
INOX / STAINLESS STEEL											
⊙ x1	VA1403.090.i	1107/20	90	72	20	33	24	17	97	200	6, 6,1
⊙ x2	VA1403.120.i2	1207/20	120	101	20	38	25	23	130	400	2, 4,5

NOTE : Valore diametro esterno nominale / External diameter nominal value / Außendurchmesser
 Nominalwert / Valeur diamètre extérieur nominal / Medida de diámetro externo nominal



TECH. INFO

VA1404

- IT Ruota gola tonda con supporto interno forato ad avvitare
- EN Half-round groove wheel with drilled internal support to screw
- DE Runde-Rille Laufrollen mit Innenstützplatte mit Löchern
- FR Roue gorge ronde avec support intérieur percé à visser
- ES Rueda canal redondo con soporte interior perforado

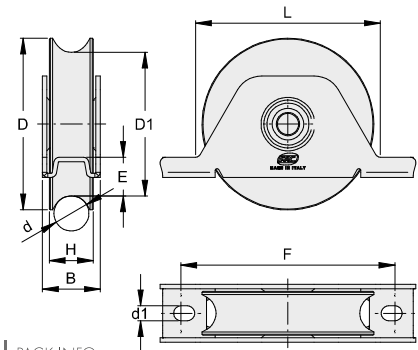

CODE	ARTICLE	D	D1	d	B	H	E	L	F	d1	CAPACITY KG	PACK INFO
ZINCATO / GALVANIZED												
⊙ x1	VA1404.090	733.90/20	90	72	20	33	24	17	106	122-115	8.5	200
	VA1404.100	-	100	82	20	33	24	22	106	122-115	8.5	200
	VA1404.120	-	120	102	20	38	24	23	130	150	9	250
	VA1404.090.2	-	90	72	20	33	25	17	106	122-115	8.5	360
⊙ x2	VA1404.100.2	-	100	82	20	33	25	22	106	122-115	8.5	360
	VA1404.120.2	733.120/20	120	102	20	38	25	23	130	150	9	400

NOTE : Valore diametro esterno nominale / External diameter nominal value / Außendurchmesser
 Nominalwert / Valeur diamètre extérieur nominal / Medida de diámetro externo nominal



TECH. INFO