

General Tolerances EN 22768-1 (ISO 2768-1)

| Class | 0,5 - 3mm | > 3 - 6mm | > 6 - 30mm | > 30 - 120mm | > 120 - 400mm |
|-------|-----------|-----------|------------|--------------|---------------|
| m | ±0,1 | ±0,1 | ±0,2 | ±0,3 | ±0,5 |
| c | ±0,2 | ±0,3 | ±0,5 | ±0,8 | ±1,2 |

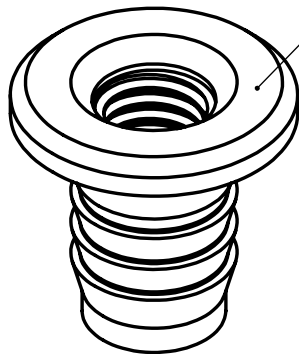

X Ray measuring point

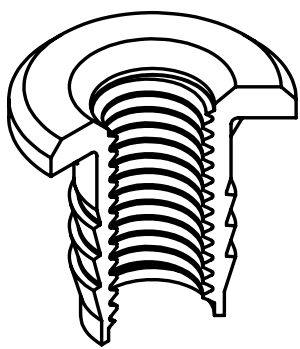
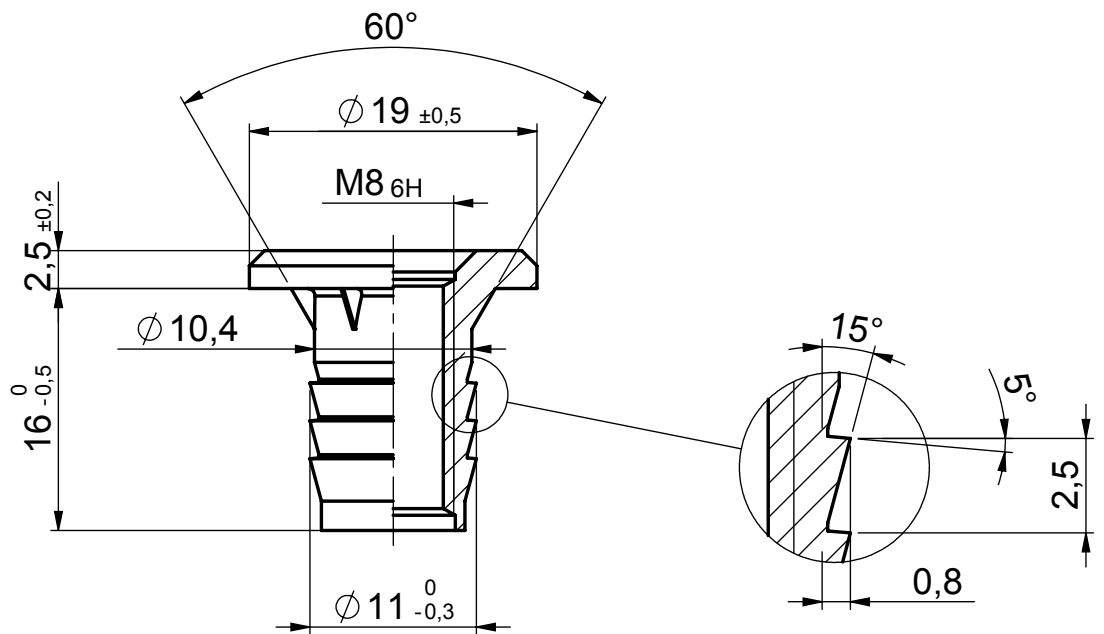
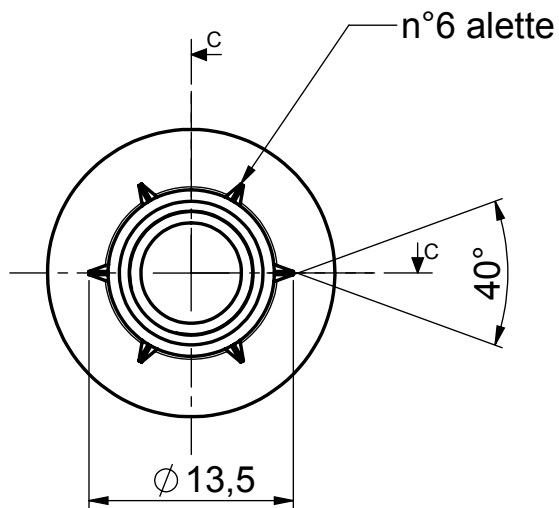

| article | d | diam | dk | ds | k | l |
|------------|-----|------|----|------|-----|-----|
| 645A00506M | M5 | 7,5 | 11 | 7,5 | 1 | 6,5 |
| 645A006014 | M6 | 9 | 14 | 8,3 | 1,5 | 14 |
| 645A008016 | M8 | 11 | 19 | 10,4 | 2,5 | 16 |
| 645A010017 | M10 | 13 | 22 | 12,4 | 2,5 | 17 |