

General Tolerances EN 22768-1 (ISO 2768-1)

Class	0,5 - 3mm	> 3 - 6mm	> 6 - 30mm	> 30 - 120mm	> 120 - 400mm
m	±0,1	±0,1	±0,2	±0,3	±0,5
c	±0,2	±0,3	±0,5	±0,8	±1,2

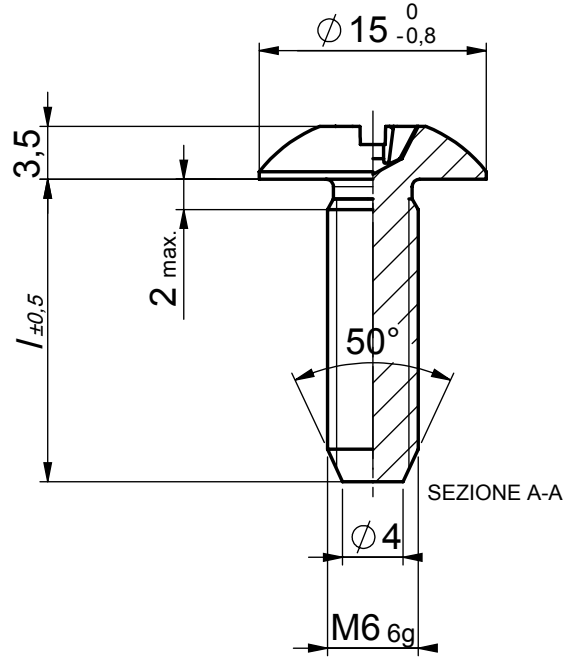

Impronta PZ3

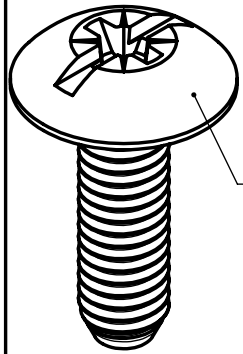
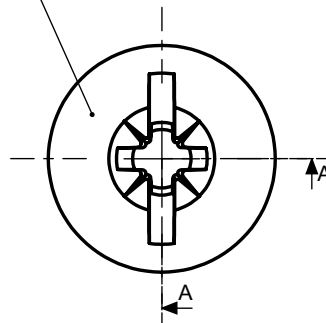

X Ray measuring point

l	Indicaz.
14	014
16	016
20	020

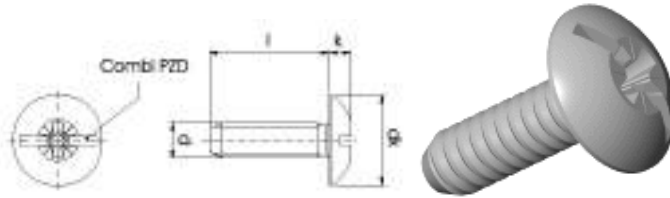

article	combi_pzd	d	dk	k	l
555C406014	3	M6	15	3,5	14
555C406016	3	M6	15	3,5	16
555C406020	M6	15	3,5	20	3