

General Tolerances EN 22768-1 (ISO 2768-1)

Class	0,5 - 3mm	> 3 - 6mm	> 6 - 30mm	> 30 - 120mm	> 120 - 400mm
m	±0,1	±0,1	±0,2	±0,3	±0,5
c	±0,2	±0,3	±0,5	±0,8	±1,2

X Ray measuring point

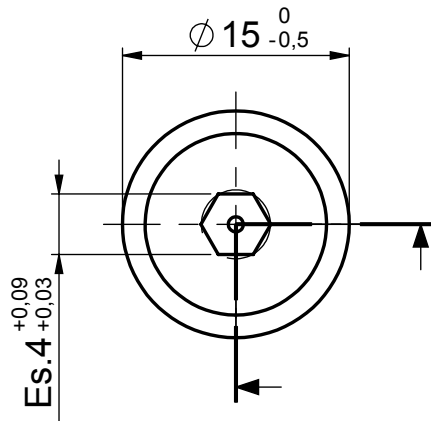
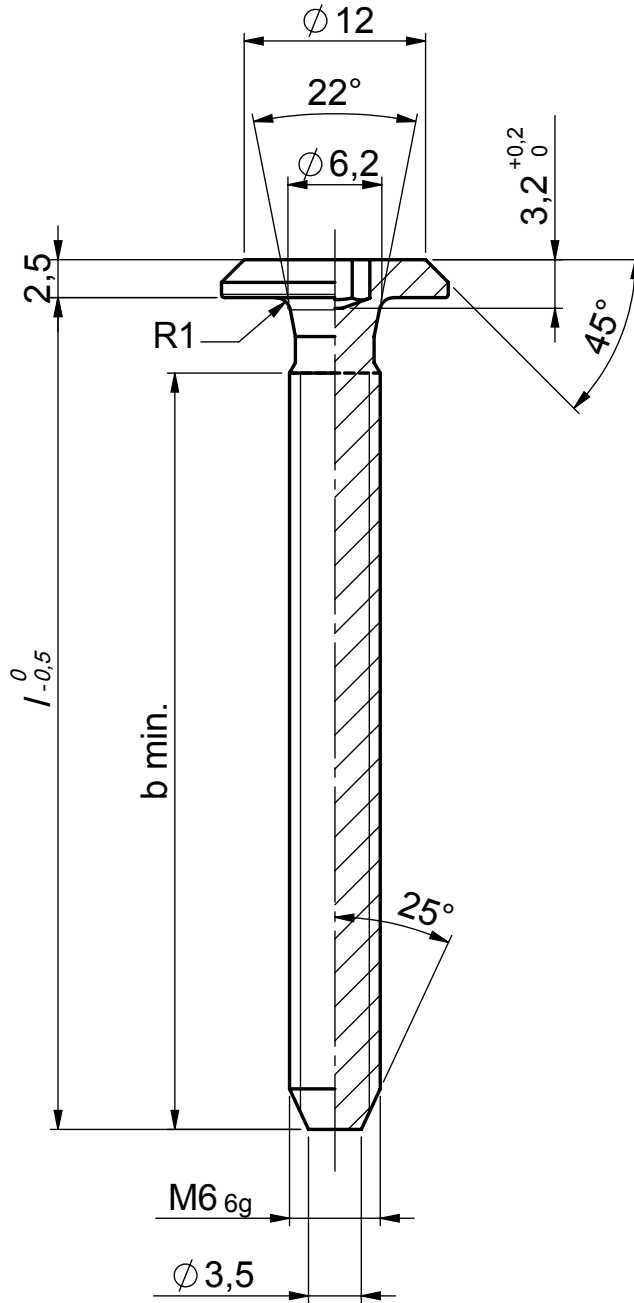
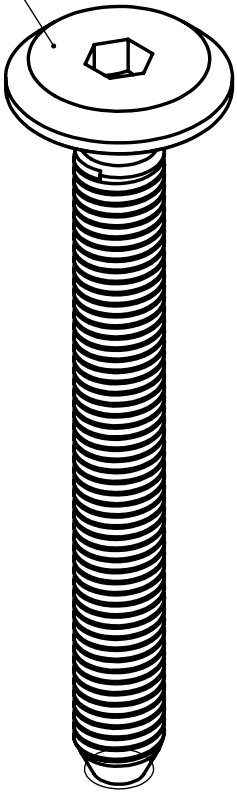

l	b	Indicaz.
12	Gambo interamente filettato	012
15		015
16		016
20		020
25		025
26		026
30		030
32		032
35		035
38		038
40		040
45		045
50		050
55		50
60	50	060
63	50	063
65	55	065
70	60	070
75	65	075
76	65	076
80	65	080
85	75	085
90	80	090
95	85	095
100	90	100
102	90	102

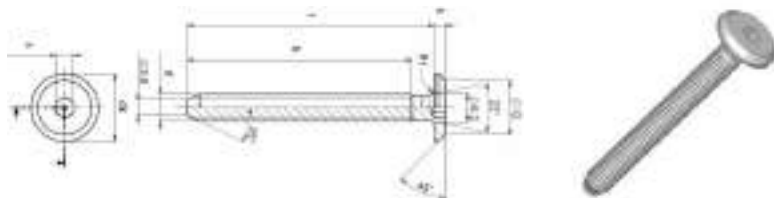

article	b	d	dk	k	l	s
562A006012	9	M6	15	2,5	12	4
562A006015	12	M6	15	2,5	15	4
562A006020	17	M6	15	2,5	20	4
562A006025	22	M6	15	2,5	25	4
562A006030	27	M6	15	2,5	30	4
562A006040	37	M6	15	2,5	40	4
562A006045	42	M6	15	2,5	45	4
562A006050	47	M6	15	2,5	50	4
562A006060	50	M6	15	2,5	60	4
562A006070	60	M6	15	2,5	70	4
562A006075	65	M6	15	2,5	75	4
562A006080	65	M6	15	2,5	80	4
562A006085	75	M6	15	2,5	85	4
562A006090	80	M6	15	2,5	90	4
562A006095	85	M6	15	2,5	95	4
562A006100	90	M6	15	2,5	100	4