

Tolleranze generali - General Tolerances EN 22768-1 (ISO 2768-1)

Class	0,5 - 3mm	> 3 - 6mm	> 6 - 30mm	> 30 - 120mm	> 120 - 400mm
f	±0,05	±0,05	±0,1	±0,15	±0,2
m	±0,1	±0,1	±0,2	±0,3	±0,5
c	±0,2	±0,3	±0,5	±0,8	±1,2

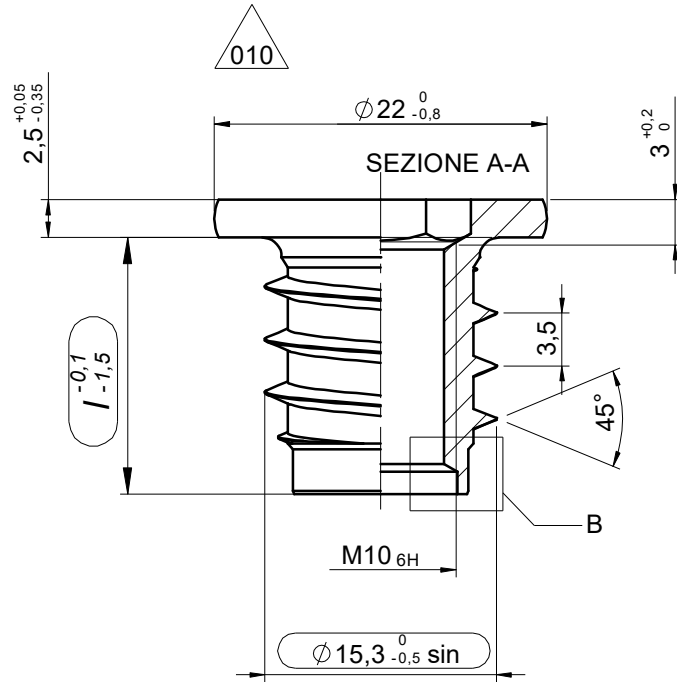

DETTAGLIO B
SCALA 4 : 1

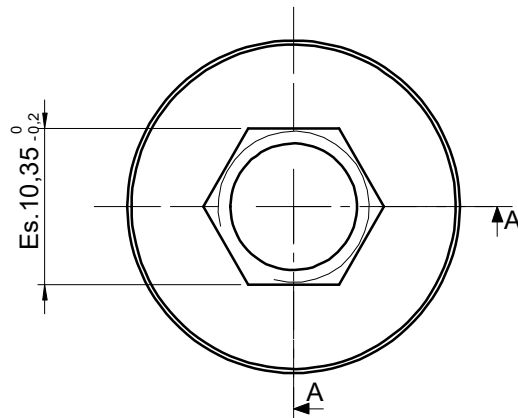
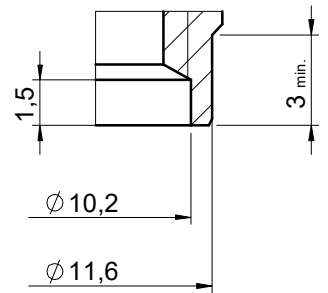

X-RAY MEASURING POINT

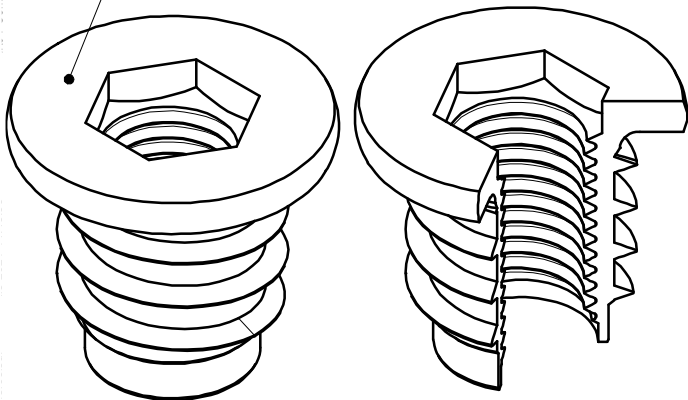

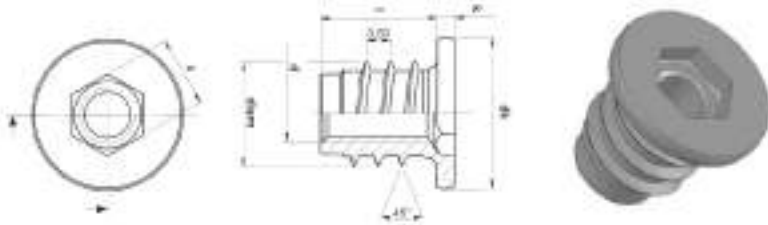

article	d	diam	dk	k	l	s	pilothole
318F508017	M8	15,3 SX	22	2,5	17	10	13
318F510017	M10	15,3 SX	22	2,5	17	10	13