



Fusital

H 369

Serie EG Duemilanove design Eri Goshen



# H 369

Serie EG Duemilanove design Eri Goshen

Materiale Nikrall Lega Zama UNI 3717	Material Nikrall Lega Zama UNI 3717
--	---

Finitura Cromsatin Cromo	Finish Satin chrome Chrome
--------------------------------	----------------------------------

## H 369

Maniglia per porta  
Door handle

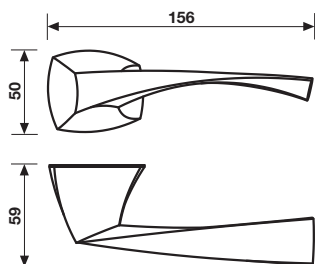

## H 369 F RS

Maniglia per finestra  
Window handle

Movimento  
4 scatti

Movement  
4 click positions

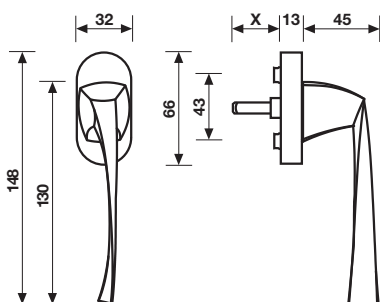

Quella che a prima vista sembra "una follia" in realtà è una maniglia molto bilanciata ed articolata. Quasi tutte le maniglie hanno tre parti distintive: la rosetta, il gambo e la impugnatura. Contrariamente a tutto questo, la "H 369" ha solo due volumi continuativi che insieme creano un'unica forma scultorea sia funzionale che molto espressiva all'apparenza. Inoltre le superfici concave e convesse che formano una "fiamma" rendono la maniglia molto dinamica ed interessante da tutte le angolazioni. Proprio simile ad una scultura molto attraente.

What looking to be just a "folly" at first glance, this handle is, in fact, very balanced and articulated; Almost all other handles have three distinctive parts: The rose, the collar and the lever. Contrary to this, the "H 369" has two continuous volumes; together they create a single, sculptured form. Being both functionally sound and very expressive in appearance. Furthermore, the concave and convex surfaces, resembling a flame, make the handle look dynamic and interesting from all angles. Very much like a fine piece of sculpture.