

cod.	mm.	pz/pcs	C	CodTek
266	GIGANTE	25	0 - 16	ASC026602LU



Sistemi di chiusura



- Componente da saldare.
- Realizzare una saldatura di dimensioni adatte a supportare le forze in gioco e con materiale d'apporto idoneo.
- Rinforzare adeguatamente le zone d'attacco.



Smaltire responsabilmente il prodotto e le sue parti d'imballaggio rispettando le normative locali nel Paese d'installazione.



Componenti in Acciaio



- Ogni 6/12 mesi controllare il prodotto.
- Nel caso si riscontrino delle anomalie, impedirne l'uso e far verificare il prodotto installato da personale professionale.

L'azienda si riserva di apportare modifiche tecniche ed estetiche senza nessun preavviso. Si declina ogni responsabilità per uso improprio dei prodotti. Ogni disegno, fotografia, marchio, logo, deve intendersi come proprietà esclusiva della Combi Arialdo. Tutti gli utilizzi non autorizzati saranno perseguiti penalmente.

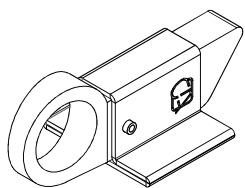
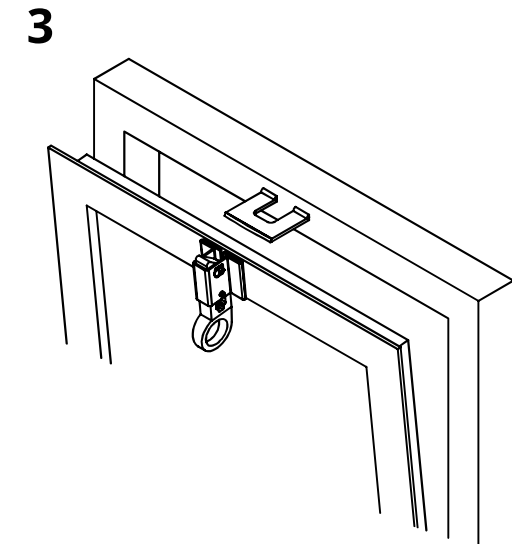
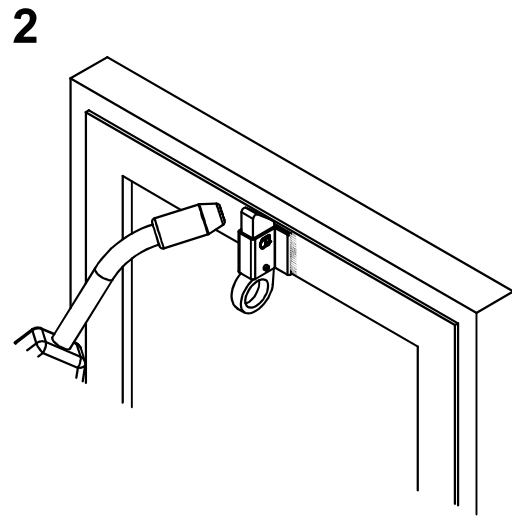
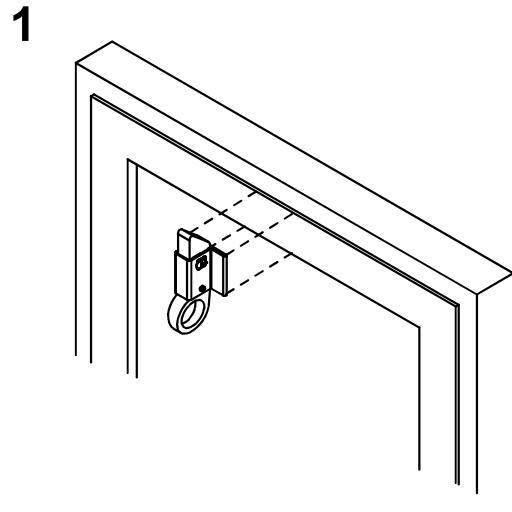
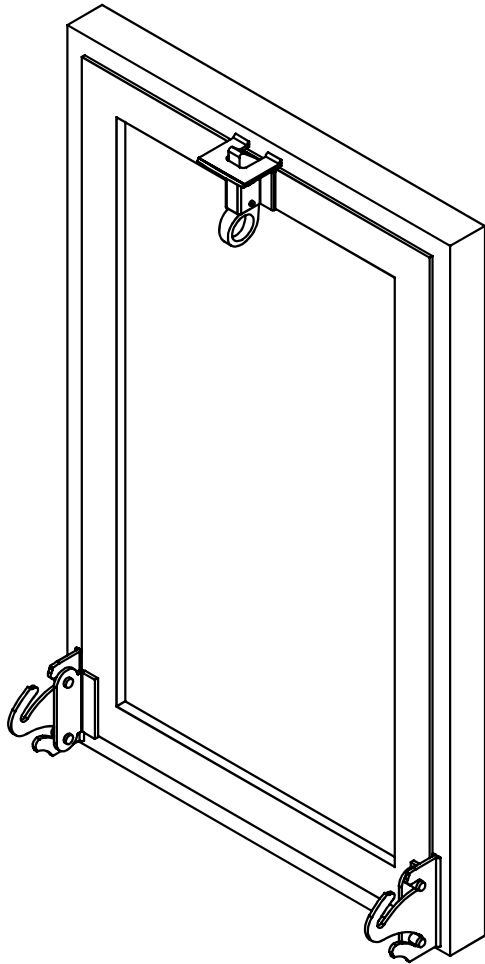

ART. 265

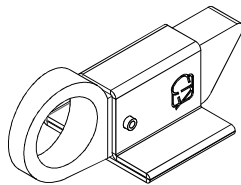

ART. 265 T

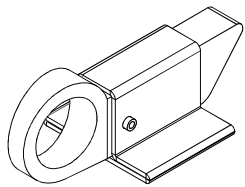

ART. 266

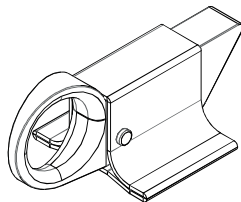

ART. 267

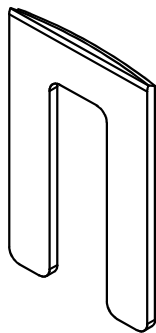
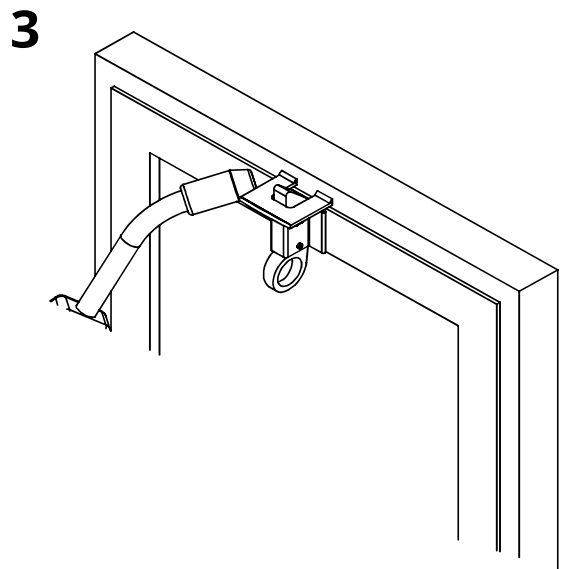
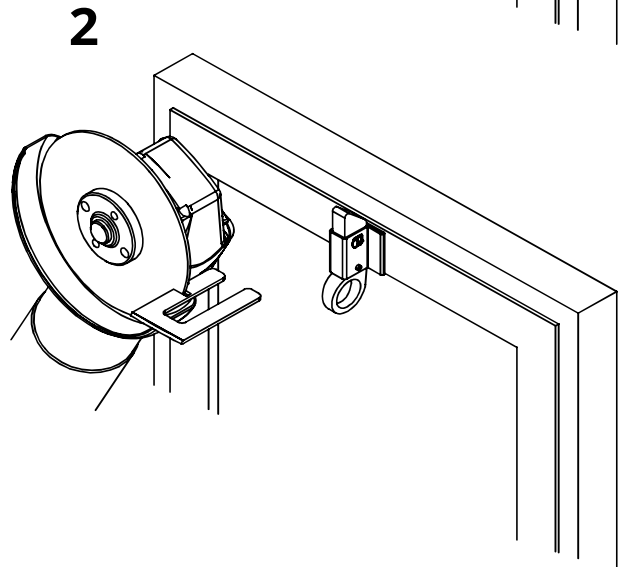
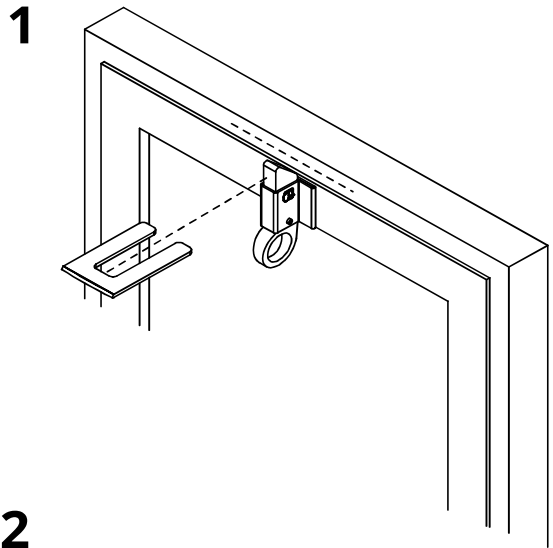
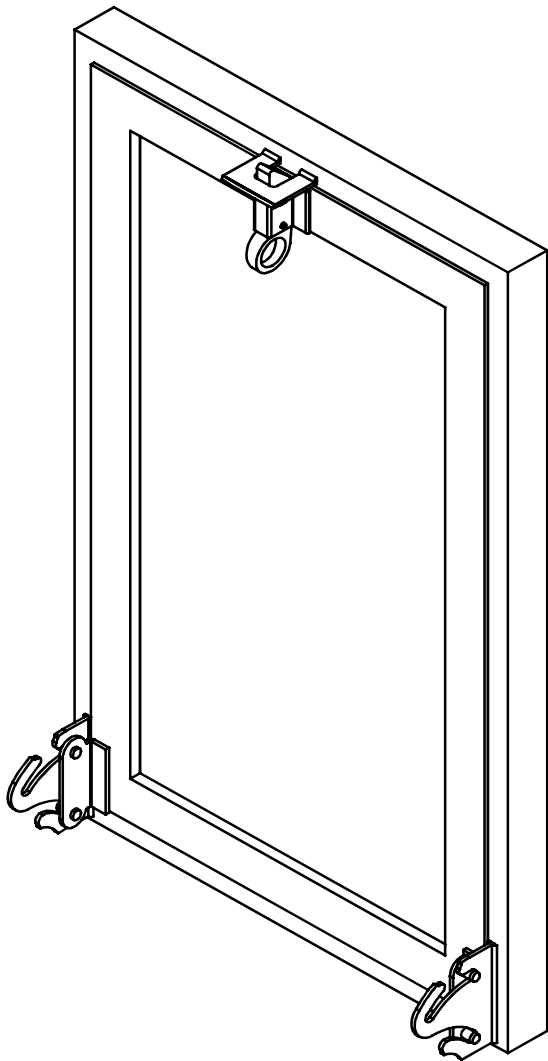

ART. 270