



EN 1627:2011 classe 2
EN 1627:2011 level 2



RIBANTA 5

Anta-ribalta Manovra tradizionale
per profili a Camera Unificata e NC International

Turn-first mechanism for traditional manoeuvre
for Euro-grooves profiles

CAMPO DI APPLICAZIONE:

- Eseguitabile con spessore Max del vetro di mm 50
- 20 Eseguitabile con spessore Max del vetro indicato (es. mm 20)
- ☒ Non eseguibile

N.B.: Lo spessore del vetro si riferisce allo spessore del materiale senza camera d'aria.

APPLICATION FIELD



- Feasible with max glass thickness of 50 mm
- 20 Feasible with max glass thickness shown (e.g. 20 mm)
- ☒ Not feasible

Note: The glass thickness refers to the thickness of the material without air space.

- Le portate e i campi di applicazione indicati sono garantiti utilizzando gli accessori su profili idonei. In caso di dimensioni e pesi importanti, contattare l'ufficio tecnico del produttore dei profili e quello di SAVIO.

- Carrying capacity and application fields are guaranteed if the accessories are fitted on suitable profiles. In case of big dimensions and weights, please contact the technical offices both of profile producer and SAVIO Spa.

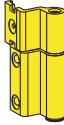
Peso max dell' anta **110 Kg** - Leaf max weight **110 Kg**

H	2630	46	39	31	26	22	19	17	15	14	13	12	11	10	9
	2600	46	39	31	26	22	19	17	15	14	13	12	11	10	9
	2500	49	41	33	27	23	20	18	16	15	13	12	11	11	10
	2400	●	43	34	29	24	21	19	17	15	14	13	12	11	10
	2300	●	45	36	30	26	22	20	18	16	15	13	12	12	11
	2200	●	48	38	32	27	23	21	19	17	15	14	13	12	11
	2100	●	●	40	33	28	25	22	20	18	16	15	14	12	11
	2000	●	●	42	35	30	26	23	21	19	17	16	14	12	11
	1900	●	●	45	37	32	28	25	22	20	18	16	14	12	11
	1800	●	●	48	40	34	29	26	23	21	19	16	14	12	11
	1700	●	●	●	42	36	31	28	25	23	19	16	14	12	11
	1600	●	●	●	45	39	34	30	27	23	20	16	14	12	11
	1500	●	●	●	49	41	36	32	28	23	20	16	14	12	10
	1400	●	●	●	●	45	39	35	28	23	20	16	14	12	10
	1300	●	●	●	●	49	42	35	29	23	20	16	14	12	9
	1200	●	●	●	●	45	36	29	24	20	16	13	10	7	
	1100	●	●	●	●	45	36	29	24	20	15	11	7	5	
	1000	●	●	●	●	45	36	29	24	17	12	8	5	X	
	900	●	●	●	●	46	36	28	19	13	8	4	X	X	
	800	●	●	●	●	46	34	22	13	7	X	X	X	X	
	X	●	●	●	●	45	28	16	8	X	X	X	X	X	
		440	500	600	700	800	900	1000	1100	1200	1300	1400	1500	1600	1700
		L													

Peso max dell' anta **140 Kg** - Leaf max weight **140 Kg**

H	2630	●	●	40	34	29	25	22	20	18	17	15	14	13	12
	2600	●	●	41	34	29	25	23	20	18	17	15	14	13	12
	2500	●	●	43	36	30	27	24	21	19	17	16	15	14	13
	2400	●	●	45	37	32	28	25	22	20	18	17	16	15	14
	2300	●	●	47	39	33	29	26	23	21	19	18	16	15	14
	2200	●	●	49	41	35	31	27	24	22	20	19	17	16	15
	2100	●	●	●	43	37	32	29	26	23	21	20	18	17	16
	2000	●	●	●	46	39	34	30	27	25	22	21	19	18	17
	1900	●	●	●	48	41	36	32	29	26	24	22	20	19	17
	1800	●	●	●	44	38	34	30	28	25	23	21	19	17	
	1700	●	●	●	47	41	36	32	29	27	25	22	19	17	
	1600	●	●	●	50	44	39	35	31	29	26	22	19	17	
	1500	●	●	●	●	47	42	37	34	31	26	22	19	17	
	1400	●	●	●	●	45	40	36	31	26	22	19	17		
	1300	●	●	●	●	49	44	37	31	26	22	19	17		
	1200	●	●	●	●	●	45	37	31	26	22	19	17		
	1100	●	●	●	●	●	45	37	31	26	22	18	14		
	1000	●	●	●	●	●	45	37	31	26	20	16	12		
	900	●	●	●	●	●	45	37	30	23	17	12	9		
	800	●	●	●	●	●	46	34	25	18	12	8	5		
	X	●	●	●	●	●	42	29	20	14	8	4	X		
		440	500	600	700	800	900	1000	1100	1200	1300	1400	1500	1600	1700
		L													

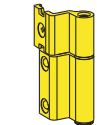
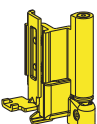
Peso max dell' anta **170 Kg** - Leaf max weight **170 Kg**

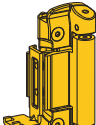

H	2630	●	●	●	42	36	31	28	25	22	20	19	17	16	15
	2600	●	●	●	42	36	31	28	25	23	21	19	18	16	15
	2500	●	●	●	44	38	33	29	26	24	22	20	18	17	16
	2400	●	●	●	46	39	34	30	27	25	23	21	19	18	17
	2300	●	●	●	48	41	36	32	29	26	24	22	20	19	17
	2200	●	●	●	●	43	38	33	30	27	25	23	21	19	17
	2100	●	●	●	●	46	40	35	32	29	26	24	22	19	17
	2000	●	●	●	●	48	42	37	33	30	28	25	22	19	17
	1900	●	●	●	●	44	39	35	32	29	26	22	19	17	
	1800	●	●	●	●	47	42	37	34	30	26	22	19	17	
	1700	●	●	●	●	44	40	36	30	26	22	19	17		
	1600	●	●	●	●	48	43	36	30	26	22	19	17		
	1500	●	●	●	●	●	44	36	31	26	22	19	17		
	1400	●	●	●	●	●	44	36	31	26	22	19	17		
	1300	●	●	●	●	●	44	37	31	26	22	19	17		
	1200	●	●	●	●	●	45	37	31	26	22	19	17		
	1100	●	●	●	●	●	45	37	31	26	22	18	14		
	1000	●	●	●	●	●	45	37	31	26	20	16	12		
	900	●	●	●	●	●	45	37	30	23	17	12	9		
	800	●	●	●	●	●	46	34	25	18	12	8	5		
	X	●	●	●	●	●	42	29	20	14	8	4	X		
		440	500	600	700	800	900	1000	1100	1200	1300	1400	1500	1600	1700
		L													

X = 730 con Cremonese / with handle



X = 765 con Martellina / with snap-latch

H = Altezza anta mobile / Moving leaf height
L = Larghezza anta mobile / Moving leaf width

Con cremonese / With handle

Pz. Pcs.	Descrizione Description	  Articoli / Code		Dimensioni anta / Leaf dimensions								
				H mm	730 1400	1401 2630	730 1400	1401 2630	730 1400	1401 2630	730 1400	1401 2630
				L mm	440 524		525 794		795 1287		1288 1700	
5	Braccio corto / Short arm	3200.750L	3200.750R	1								
5	Braccio standard / Standard arm	3200.751L	3200.751R	1								
5	Braccio lungo / Long arm	3200.752L	3200.752R	1								
5	Braccio supplementare / Supplementary arm	3200.800L	3200.800R	1								
5	Kit per 6 punti di chiusura (H>1400 mm) / Kit for 6 locking points (H>1400 mm)	3200.820L	3200.820R		1		1		1		1	
5	Kit per 8 punti di chiusura (L>1400 mm) / Kit for 8 locking points (L>1400 mm)	3200.825L	3200.825R	1								
5	Kit con fulcro orizzontale (con cardine e supporto) / Kit with horizontal fulcrum (with hinge pivot and support)	3200.2L	3200.2R	1								
5	Kit di cerniere ambidestre (portata 110 Kg) / Kit of non-handed hinges (weight capacity of 110 Kg)	3200.709	3200.709	1								
5	Kit di cerniere ambidestre (portata 70 Kg) per compl. int. / Kit for non-handed hinges (weight capacity of 70 Kg) for internally flush profiles	3200.740	3200.740	1								
5	Kit di cerniere ambidestre (portata 70 Kg) per compl. int. con dente da 4 mm / Kit for non-handed hinges (weight capacity of 70 Kg) for internally flush profiles	3200.745	3200.745	1								
5	Kit di rinforzo per cern. sup. (portata 140 Kg) / Reinforcement kit for top hinge (weight capacity of 140 Kg)	3200.708L	3200.708R	1								
5	Kit di cerniere ambidestre (portata 170 Kg) / Kit of non-handed hinges (weight capacity of 170 Kg)	3200.701	3200.701	1								
20	Supporto cerniera (portata 170 Kg) / Hinge support (weight capacity of 170 Kg)	3200.700L	3200.700R	1								
40	Innesto cremonese / Handle connection piece	3200.705L	3200.705R	1								
20	Kit rostro per cave telaio 14-18 mm / Anti-burglar device for groove 14-18 mm	3200.836		4	6	4	6	4	6	6	8	
20	Kit rostro per cave telaio 14-18 mm / Anti-burglar device for groove 10-14 mm	3200.838										
5	Kit di sicurezza SKG / SKG security kit	3200.837L	3200.837R	1								

Con martellina / With snap latch

Pz. Pcs.	Descrizione Description	  Articoli / Code		Dimensioni anta / Leaf dimensions								
				H mm	765 1400	1401 2630	765 1400	1401 2630	765 1400	1401 2630	765 1400	1401 2630
				L mm	440 524		525 794		795 1287		1288 1700	
5	Braccio corto / Short arm	3200.750L	3200.750R	1								
5	Braccio standard / Standard arm	3200.751L	3200.751R	1								
5	Braccio lungo / Long arm	3200.752L	3200.752R	1								
5	Braccio supplementare / Supplementary arm	3200.800L	3200.800R	1								
5	Kit per 6 punti di chiusura (H>1400 mm) / Kit for 6 locking points (H>1400 mm)	3200.820L	3200.820R		1		1		1		1	
5	Kit per 8 punti di chiusura (L>1400 mm) / Kit for 8 locking points (L>1400 mm)	3200.825L	3200.825R	1								
5	Kit con fulcro orizzontale (con cardine e supporto) / Kit with horizontal fulcrum (with hinge pivot and support)	3200.2L	3200.2R	1								
5	Kit di cerniere ambidestre (portata 110 Kg) / Kit of non-handed hinges (weight capacity of 110 Kg)	3200.709	3200.709	1								
5	Kit di cerniere ambidestre (portata 70 Kg) per compl. int. / Kit for non-handed hinges (weight capacity of 70 Kg) for internally flush profiles	3200.740	3200.740	1								
5	Kit di cerniere ambidestre (portata 70 Kg) per compl. int. con dente da 4 mm / Kit for non-handed hinges (weight capacity of 70 Kg) for internally flush profiles	3200.745	3200.745	1								
5	Kit di rinforzo per cern. sup. (portata 140 Kg) / Reinforcement kit for top hinge (weight capacity of 140 Kg)	3200.708L	3200.708R	1								
5	Kit di cerniere ambidestre (portata 170 Kg) / Kit of non-handed hinges (weight capacity of 170 Kg)	3200.701	3200.701	1								
20	Supporto cerniera (portata 170 Kg) / Hinge support (weight capacity of 170 Kg)	3200.700L	3200.700R	1								
40	Innesto per meccanismo monodirezionale / Handle connection piece for mono directional gearbox	3200.706		1								
20	Kit rostro per cave telaio 14-18 mm / Anti-burglar device for groove 14-18 mm	3200.836		4	6	4	6	4	6	6	8	
20	Kit rostro per cave telaio 14-18 mm / Anti-burglar device for groove 10-14 mm	3200.838										
5	Kit di sicurezza SKG / SKG security kit	3200.837L	3200.837R	1								

LAVORAZIONE ANTA MOBILE (Destra) - MOVING SASH MACHINING (RH)

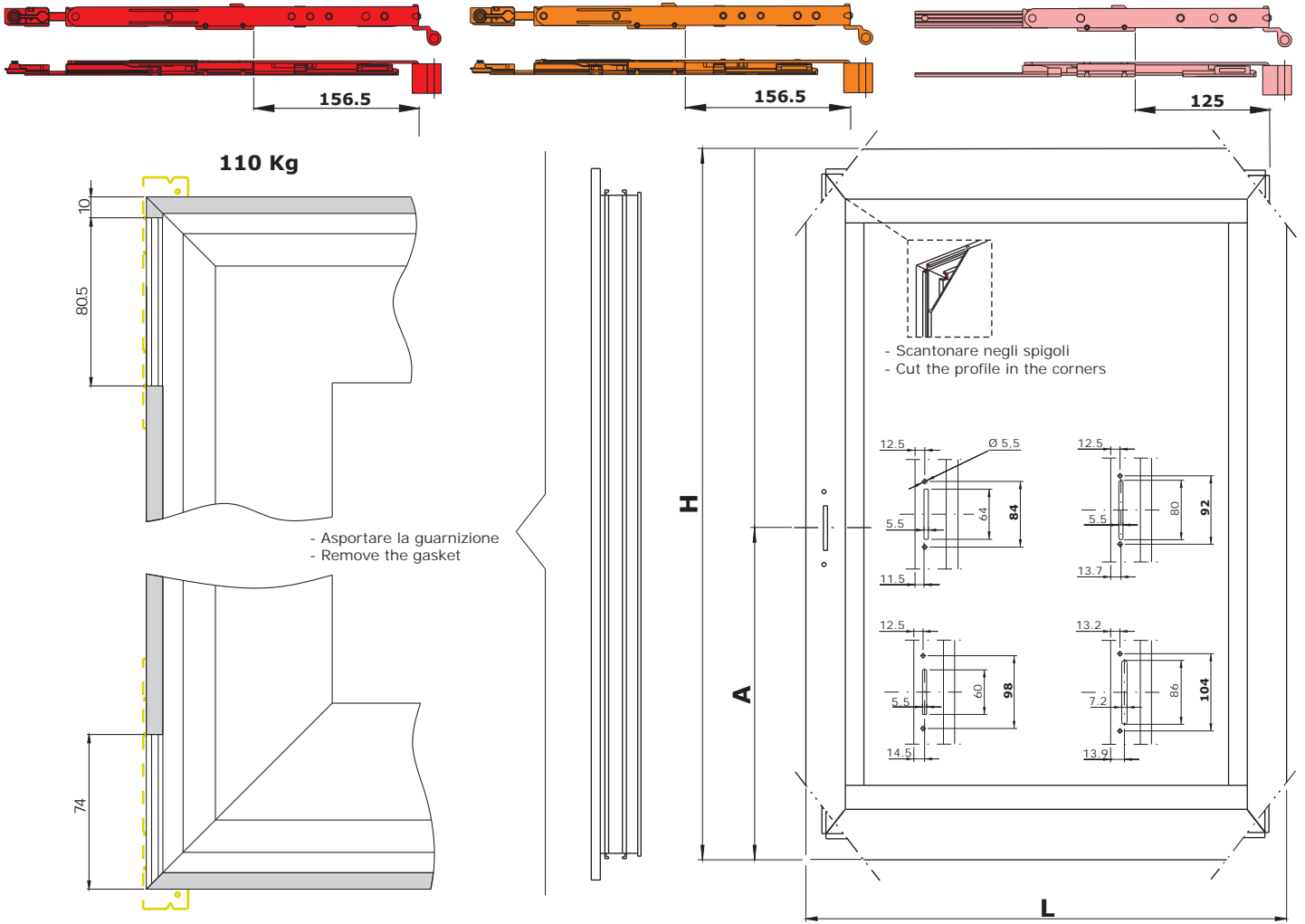

H < 1400 mm

con Cremonese / with Handle (**A** min. = 350 mm - **A** max. = H - 380 mm)
 con Martellina / with Snap-latch (**A** min. = 350 mm - **A** max. = H - 415 mm)

H > 1400 mm

con Cremonese / with Handle (**A** min. = 850 mm - **A** max. = H - 800 mm)
 con Martellina / with Snap-latch (**A** min. = 900 mm - **A** max. = H - 850 mm)

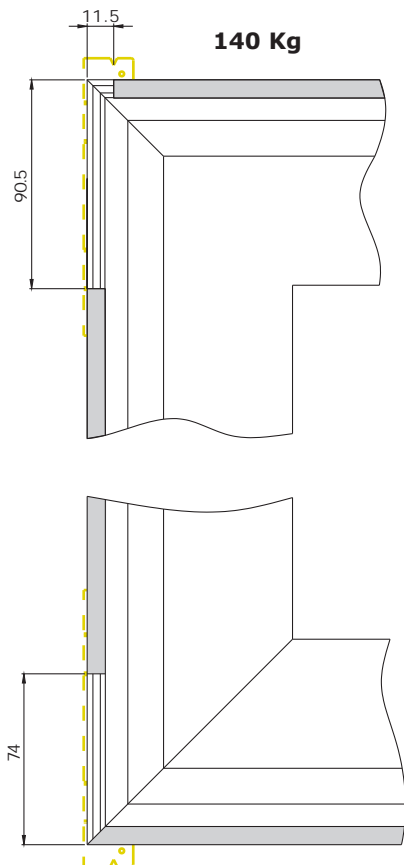

140 Kg

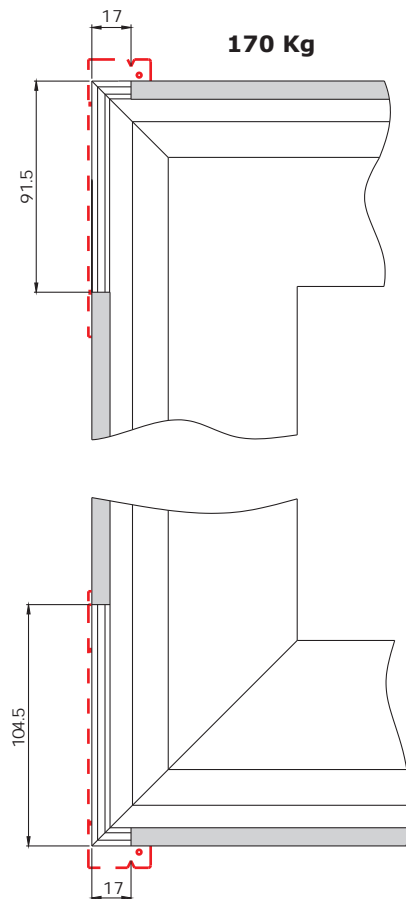

170 Kg

Asportare la guarnizione - Remove the gasket

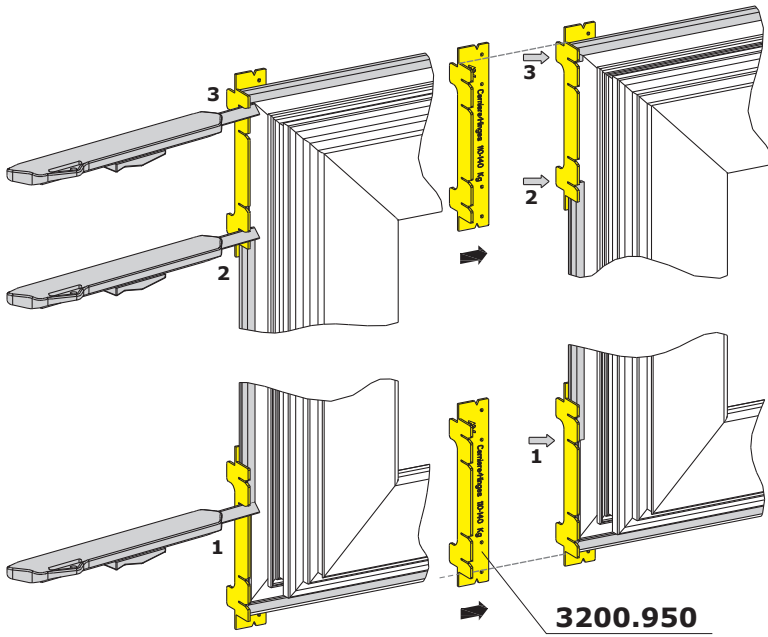

110 Kg

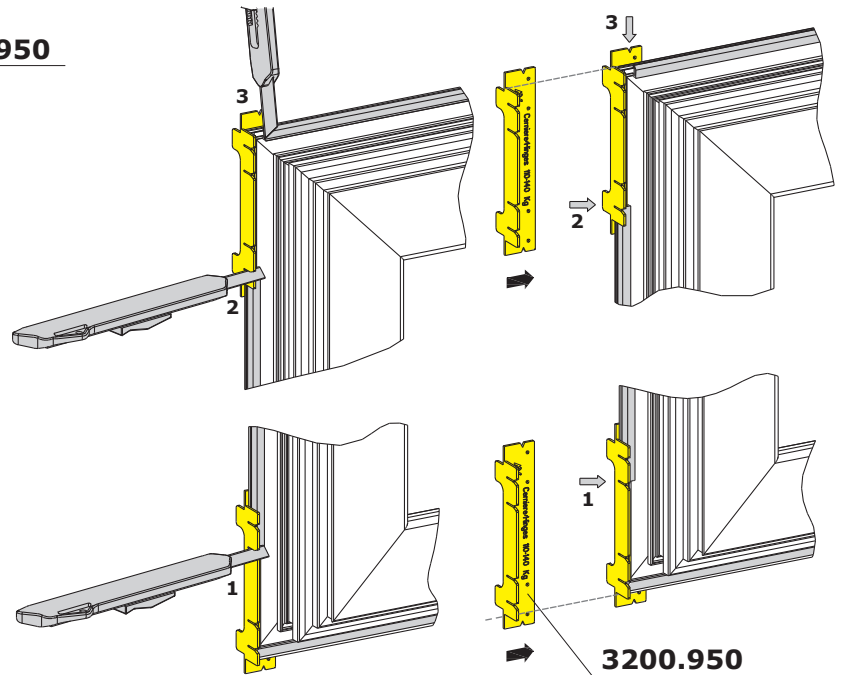

140 Kg

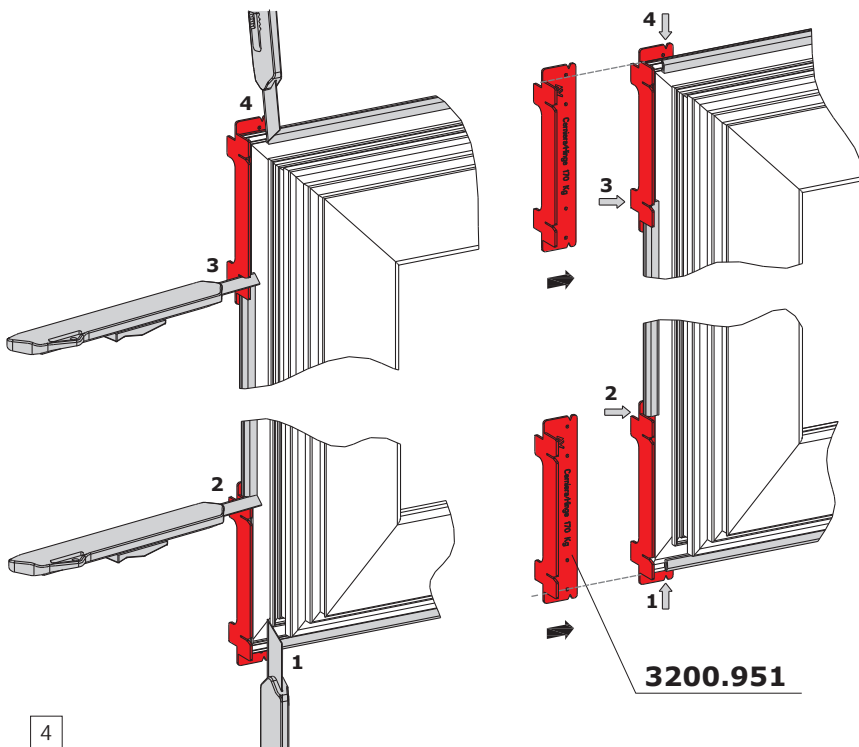

170 Kg

POSIZIONAMENTO ACCESSORI SU TELAIO FISSO (DESTRO) - ACCESSORIES POSITIONING ON FIXED FRAME (RH)

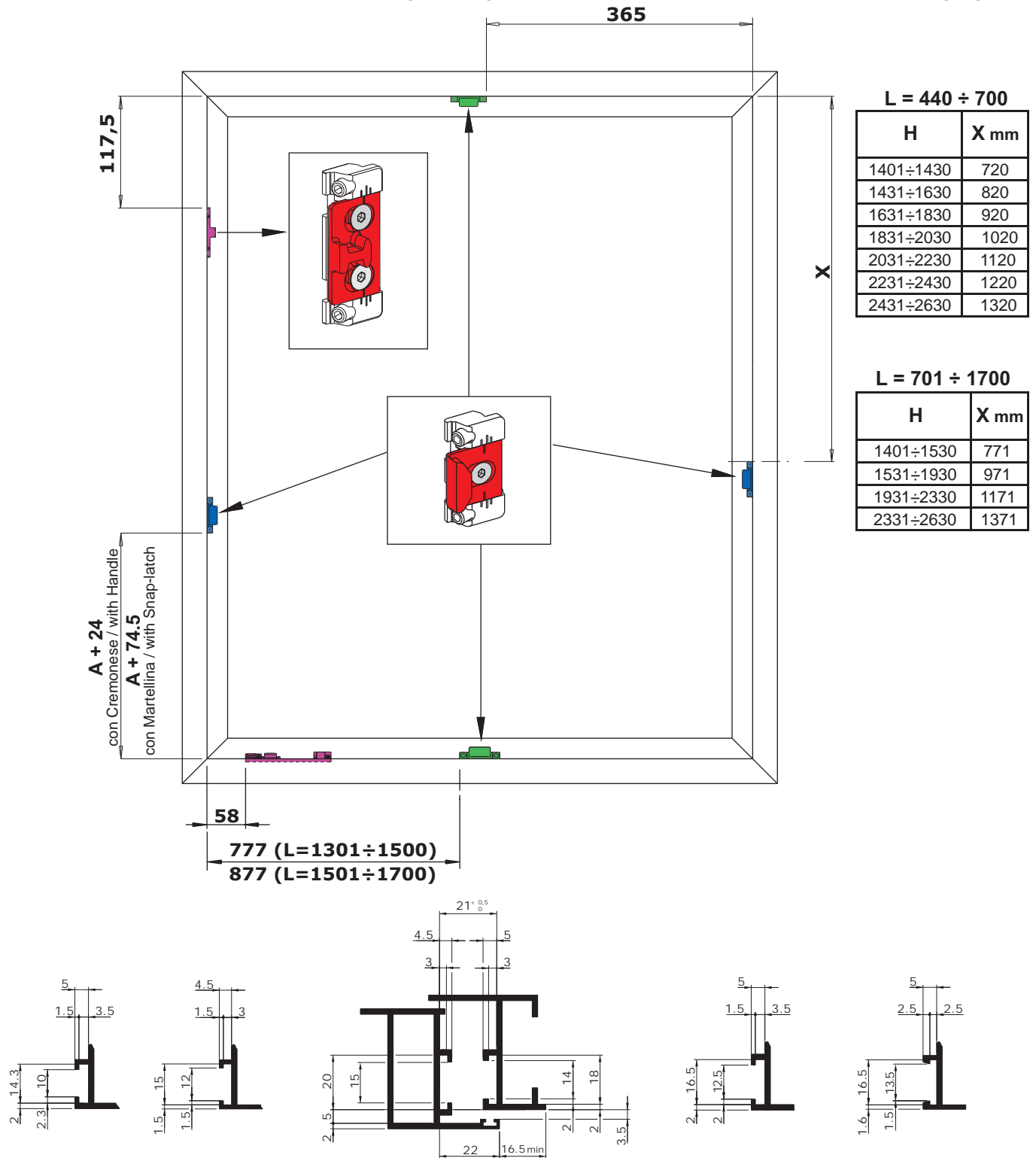

Dima di posizionamento accessori su telaio fisso - Accessories positioning jig on fixed frame

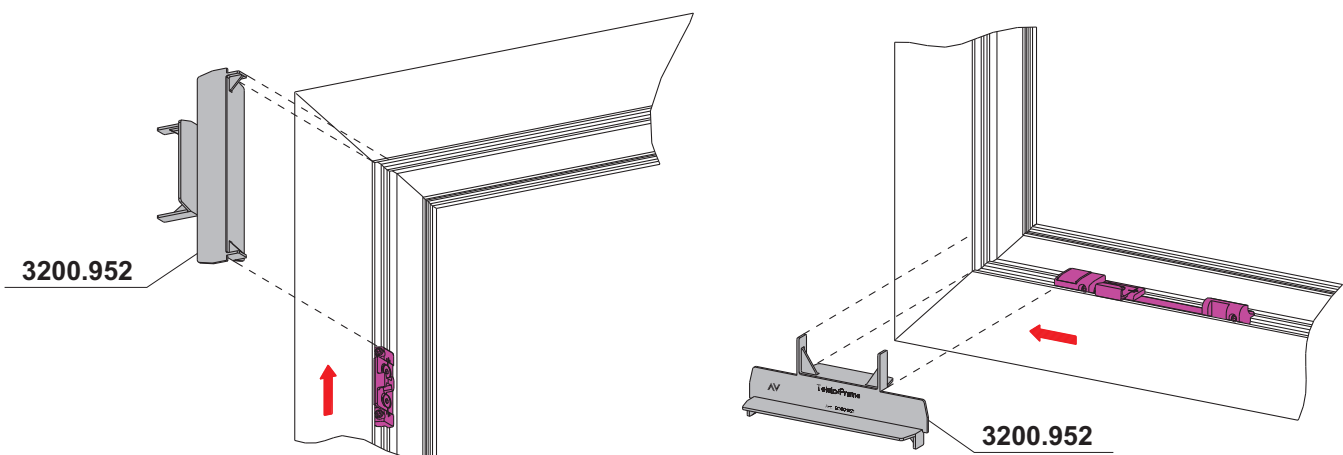

POSIZIONAMENTO KIT DI SICUREZZA SKG ART. 3200.837R/L SU TELAIO FISSO (DESTRO) H<1400
SKG SECURITY KIT POSITIONING ART. 3200.837R/L ON FIXED FRAME (RH) H<1400

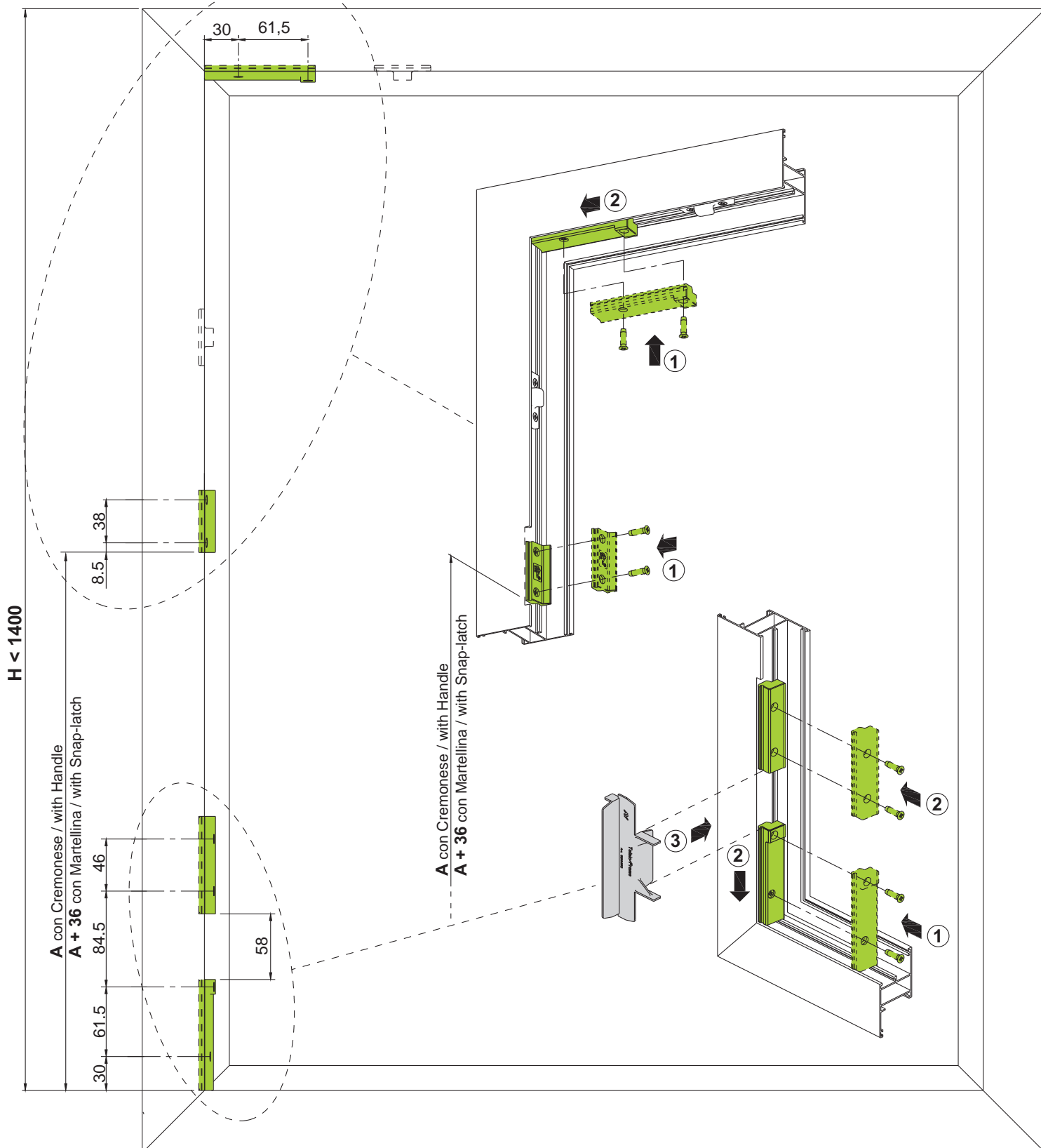
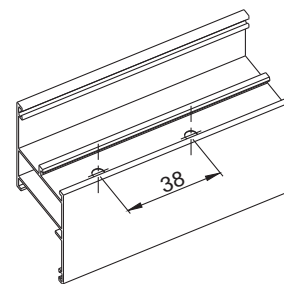
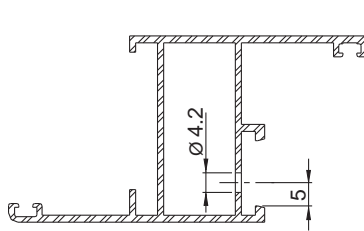
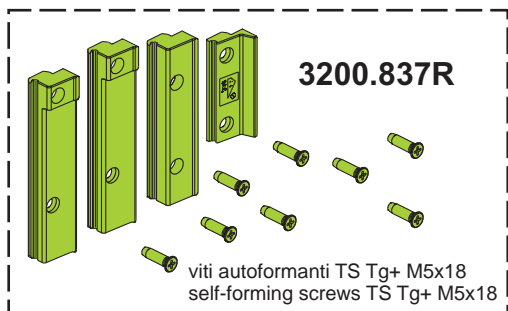

POSIZIONAMENTO KIT DI SICUREZZA SKG ART. 3200.837R/L SU TELAIO FISSO (DESTRO) H>1400
SKG SECURITY KIT POSITIONING ART. 3200.837R/L ON FIXED FRAME (RH) H>1400

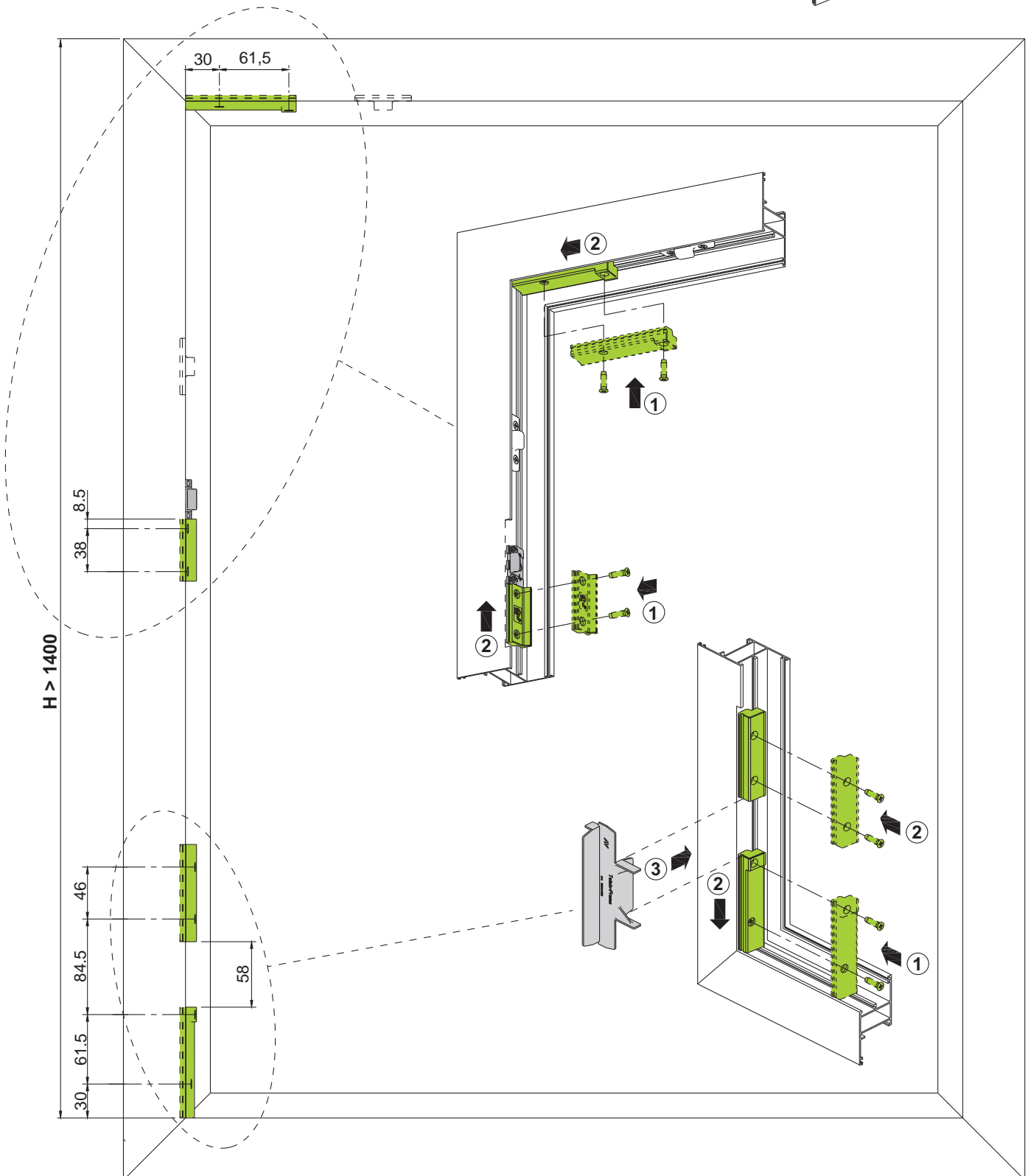
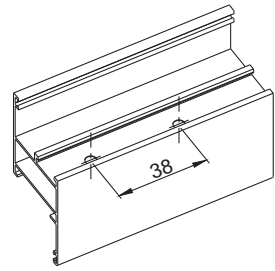
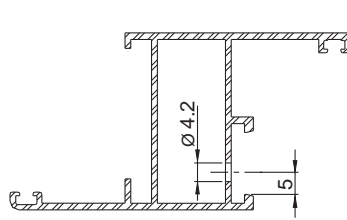
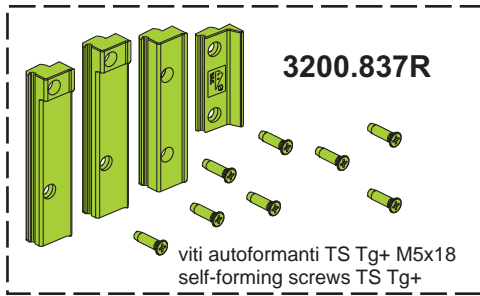

Foratura del telaio fisso - Fixed frame drilling

-Forare Ø 4,2 mm. Se occorre forare la squadretta, aumentare il foro a Ø 4,5 mm per una profondità di almeno 15 mm e lubrificare.
 -Drill Ø 4.2 mm. If you need to drill the corner cleat, increase the hole to Ø 4.5 mm to a depth of at least 15 mm and lubricate.

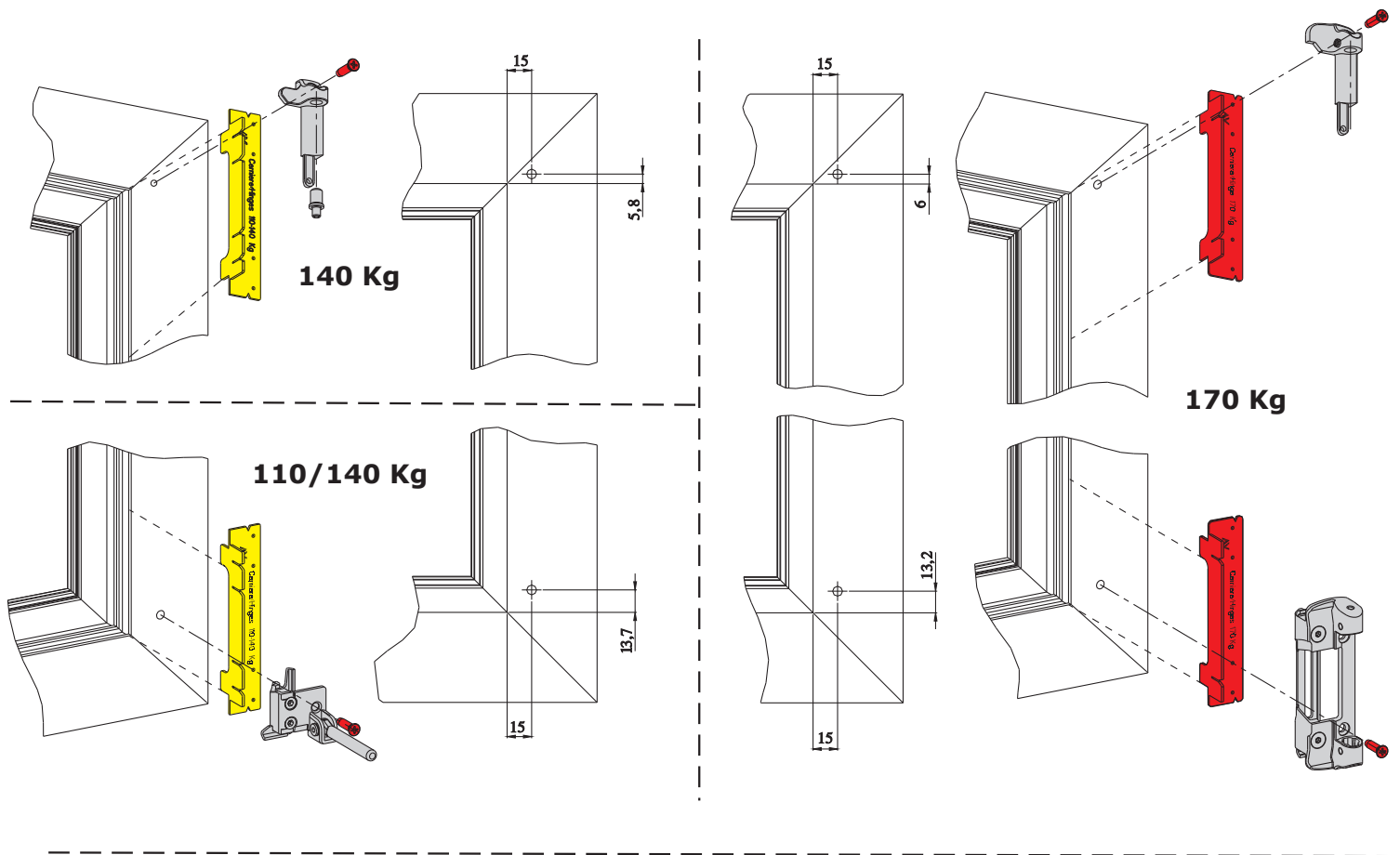

Montaggio delle cerniere sul telaio fisso (dx) -Hinges assembly on the fixed frame (RH)

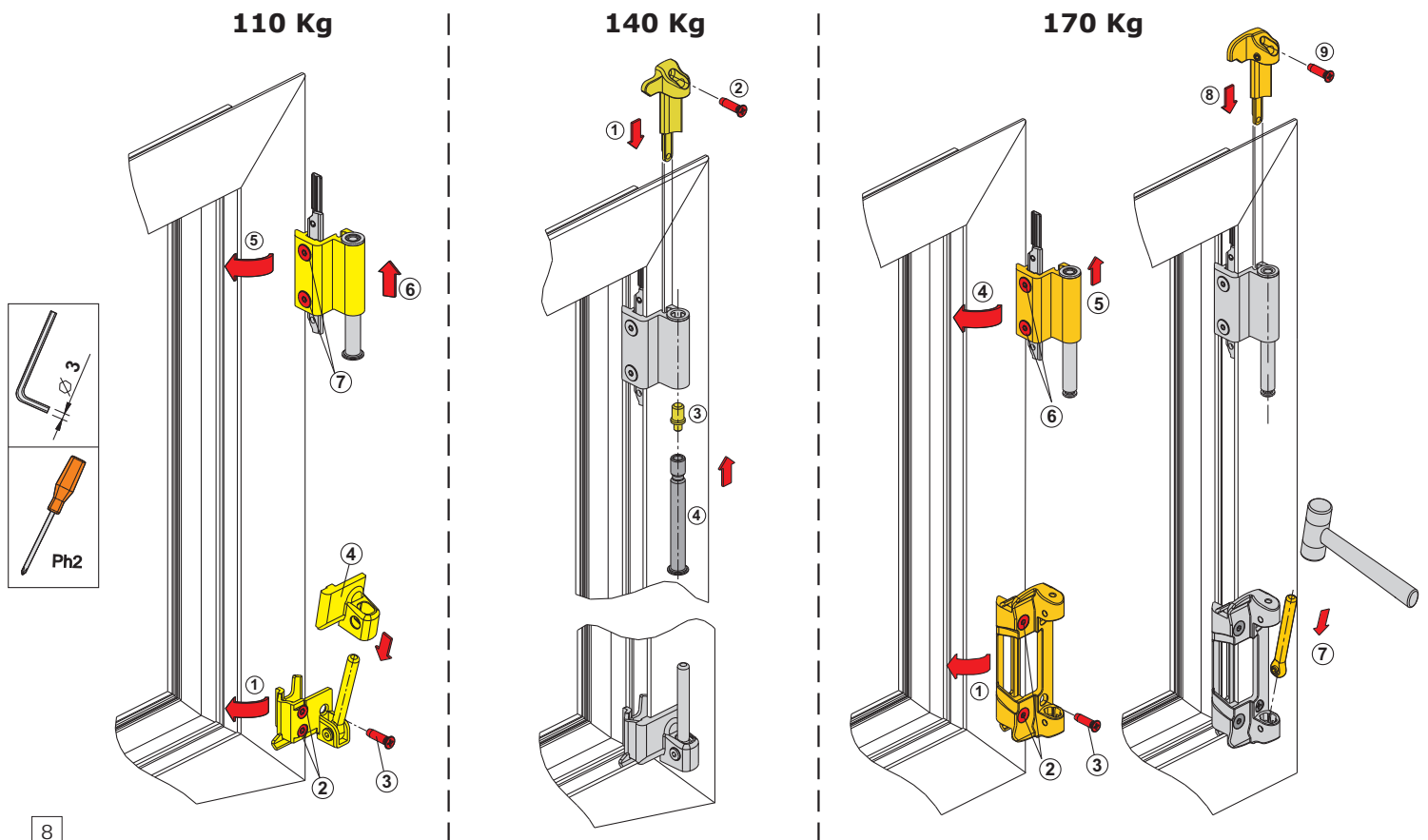

Assemblaggio anta su telaio - Leaf assembly on the frame

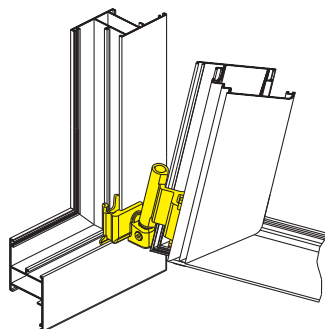
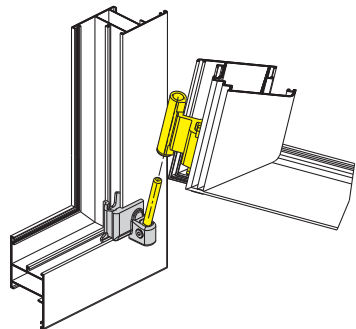
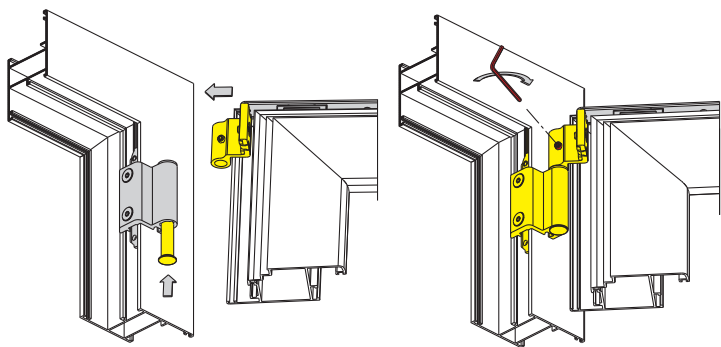

110 Kg

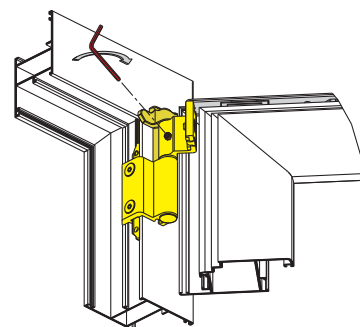
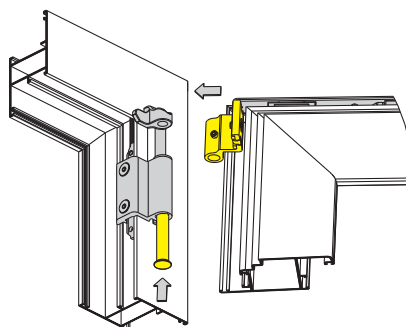

140 Kg

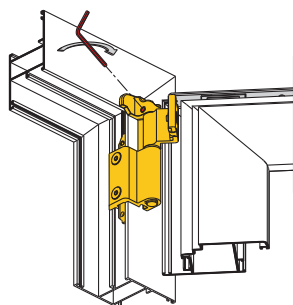
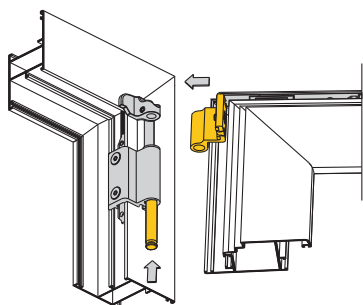
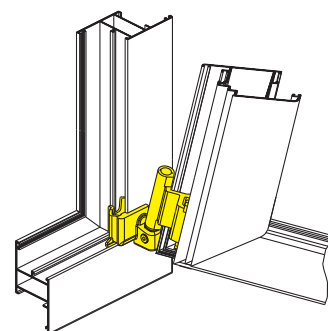
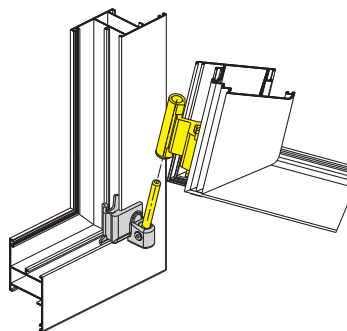

170 Kg

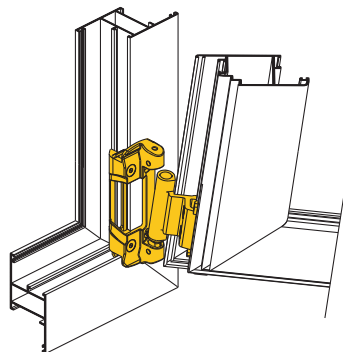
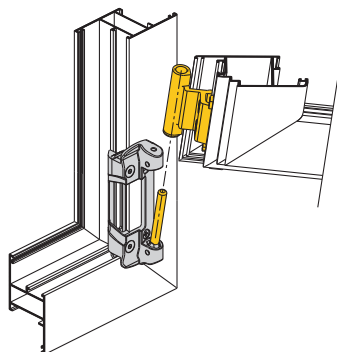

POSIZIONAMENTO ACCESSORI SU TELAIO FISSO (DESTRO)
ACCESSORIES POSITIONING ON FIXED FRAME (RH)

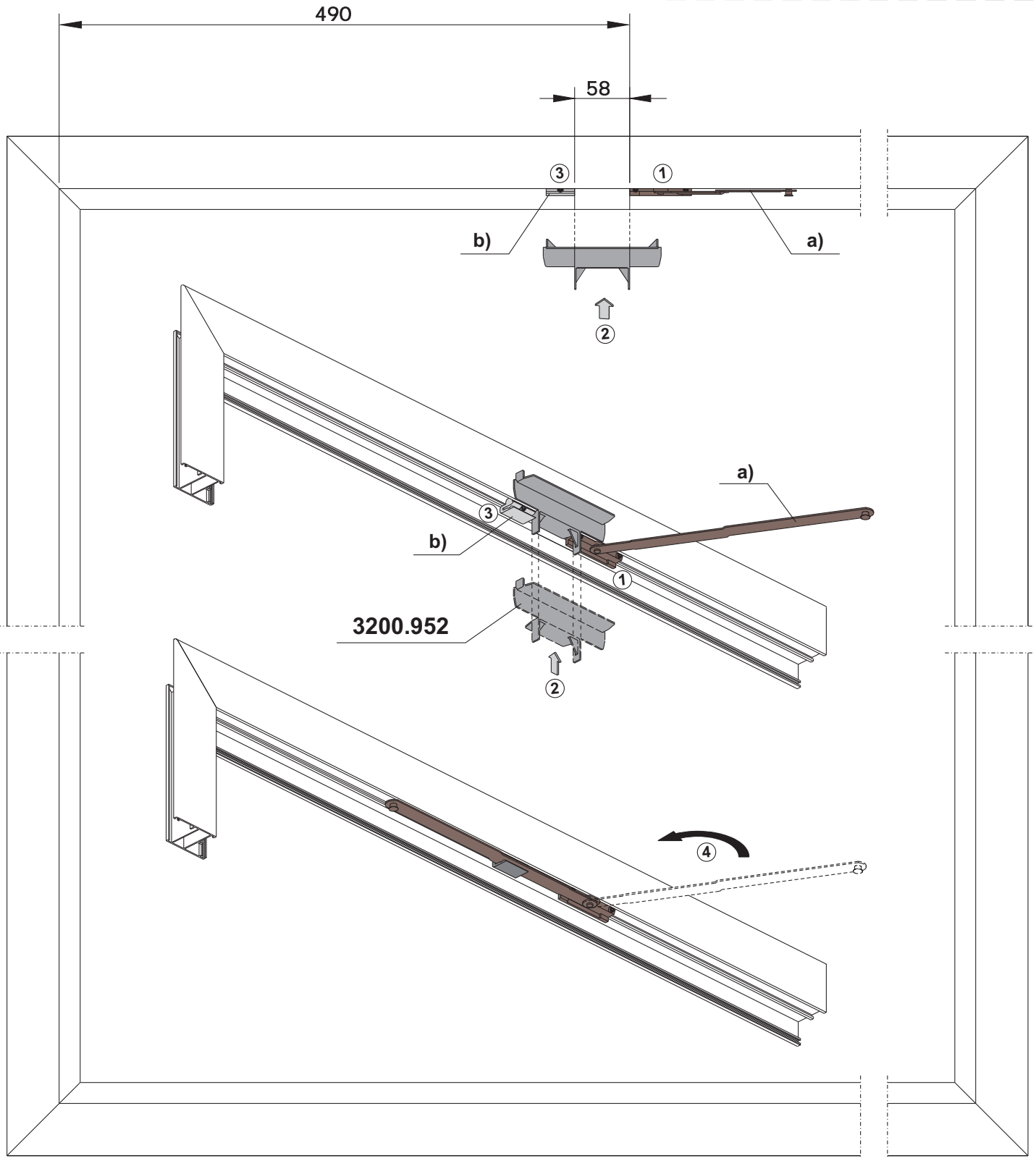
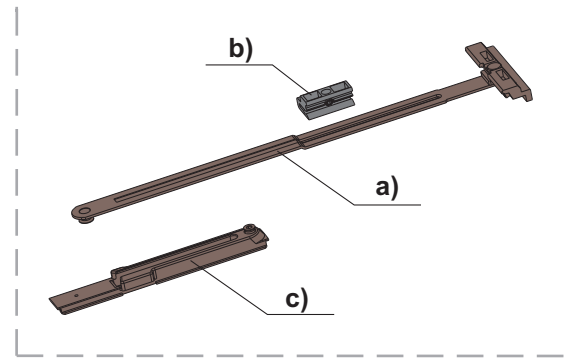

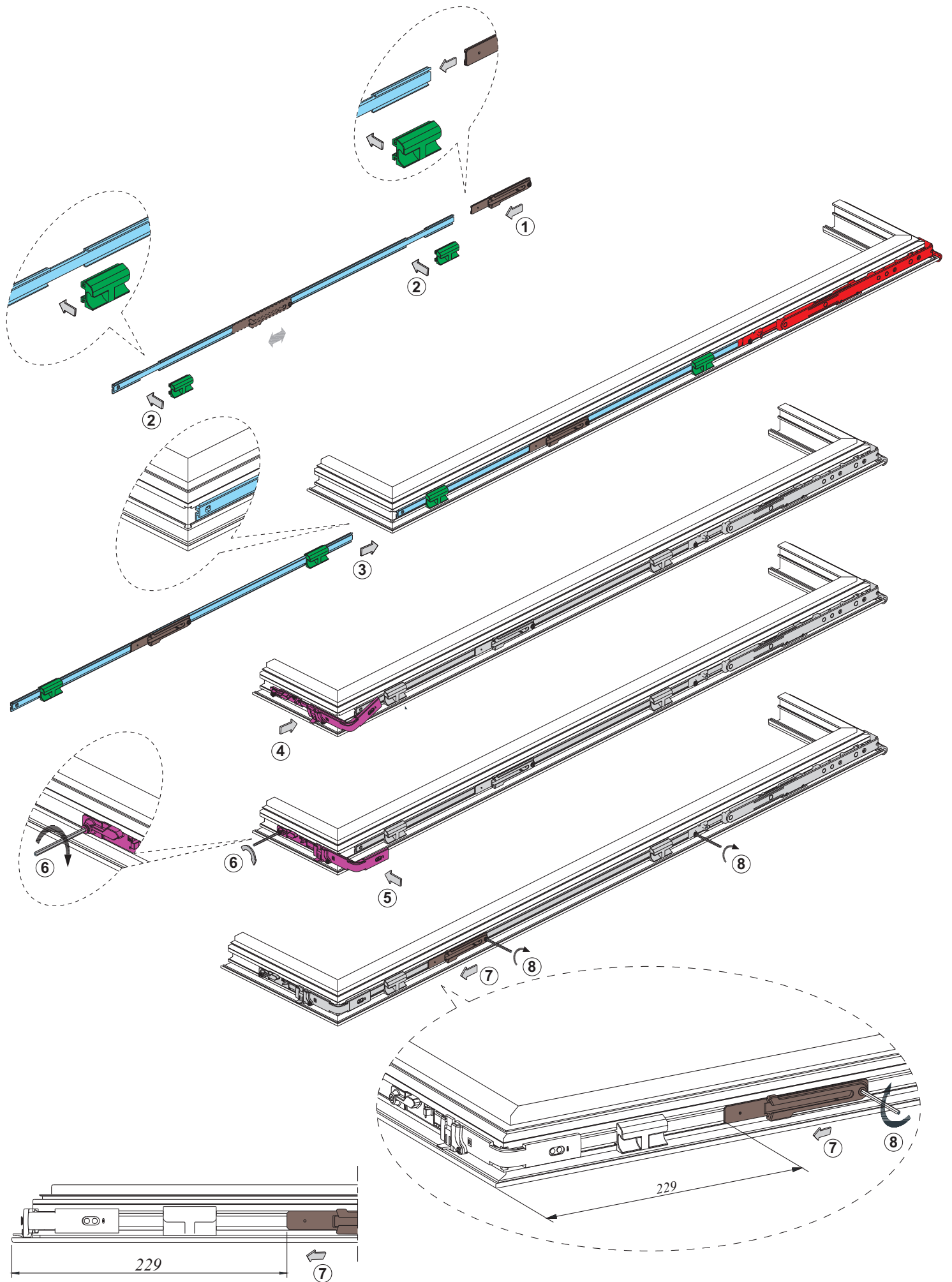

POSIZIONAMENTO KIT ROSTRI SU TELAIO FISSO (DESTRO) - ANTI-BURGLAR DEVICE POSITIONING ON FIXED FRAME (RH)

Per il posizionamento degli accessori sull'anta vedere pag. 24/25 - For accessories positioning on leaf, see page 24/25

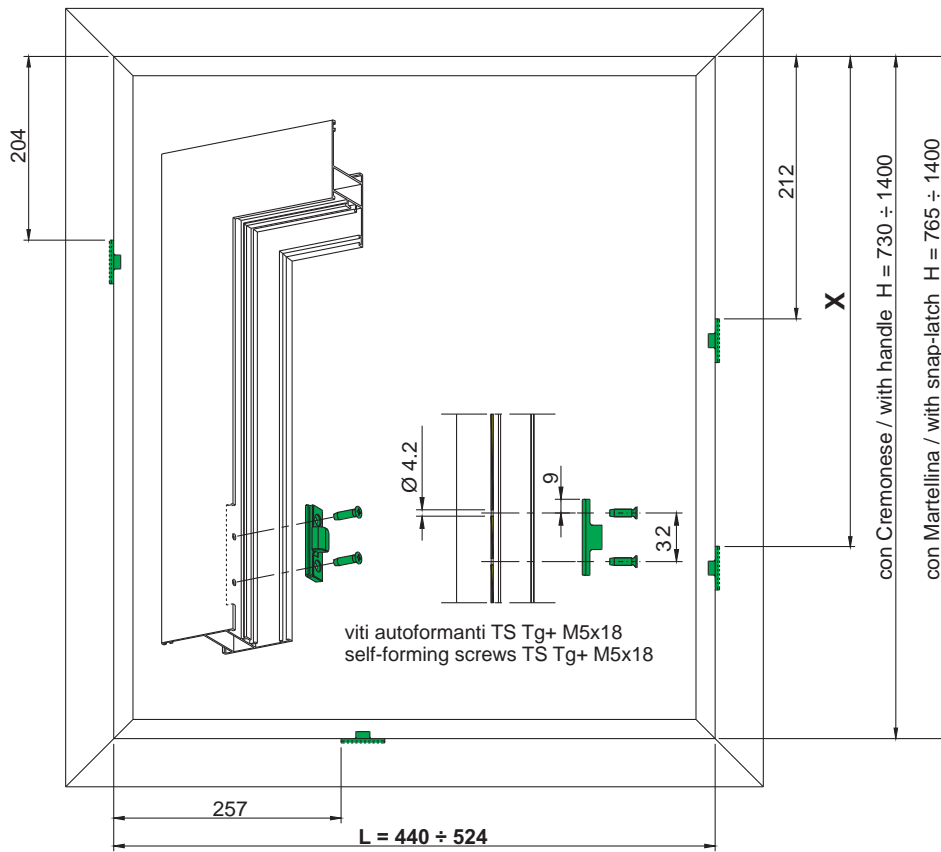

H	X mm
(730-765)÷830	438
831÷1030	638
1031÷1230	838
1231÷1400	1038

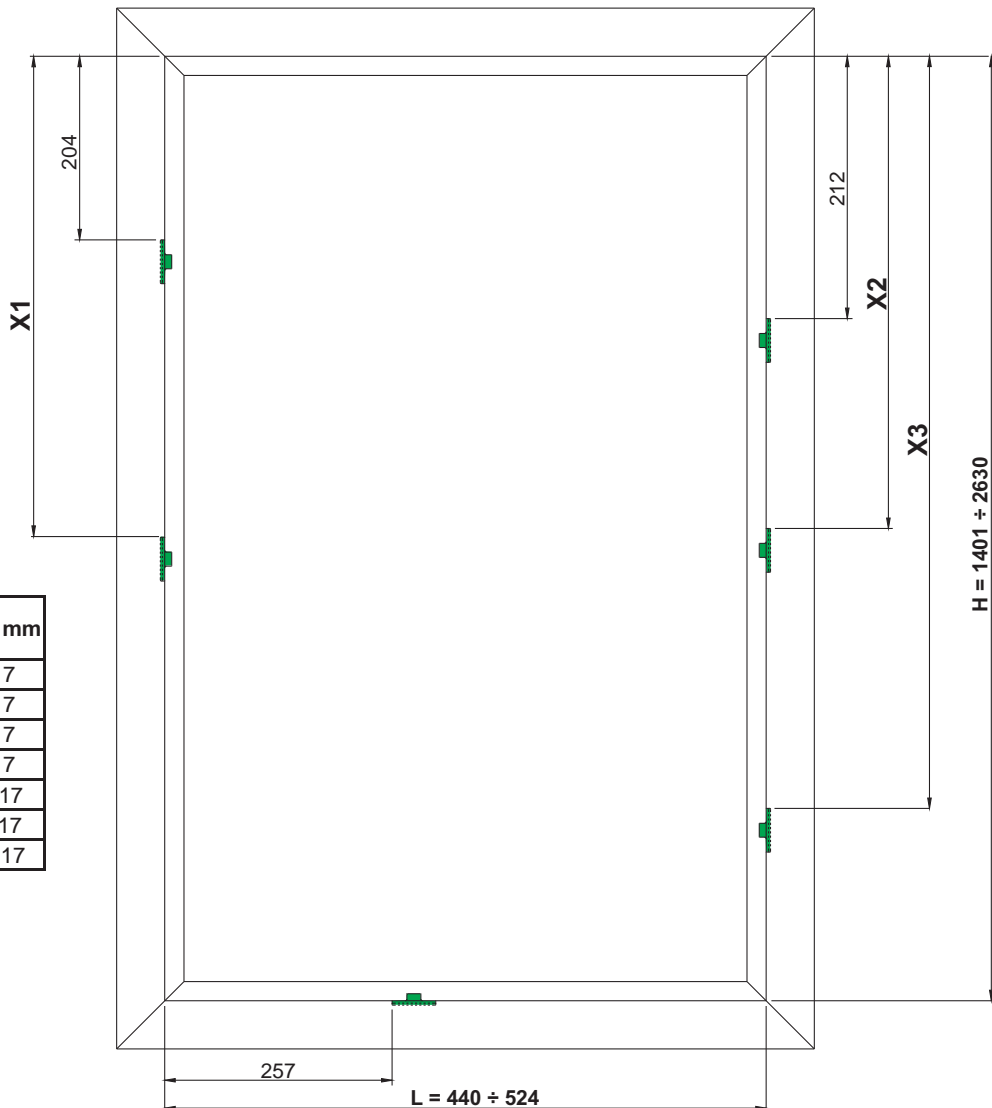

H	X2 mm
1401÷1430	625
1431÷1630	725
1631÷1830	825
1831÷2030	925
2031÷2230	1025
2231÷2430	1125
2431÷2630	1225

H	X1 mm
1401÷1500	617
1501÷1700	717
1701÷1900	817
1901÷2100	917
2101÷2300	1017
2301÷2500	1117
2501÷2630	1217

H	X3 mm
1401÷1430	1038
1431÷1630	1238
1631÷1830	1438
1831÷2030	1638
2031÷2230	1838
2231÷2430	2038
2431÷2630	2238

POSIZIONAMENTO KIT ROSTRI SU TELAIO FISSO (DESTRO) - ANTI-BURGLAR DEVICE POSITIONING ON FIXED FRAME (RH)

Per il posizionamento degli accessori sull'anta vedere pag. 26/27 - For accessories positioning on leaf, see page 26/27

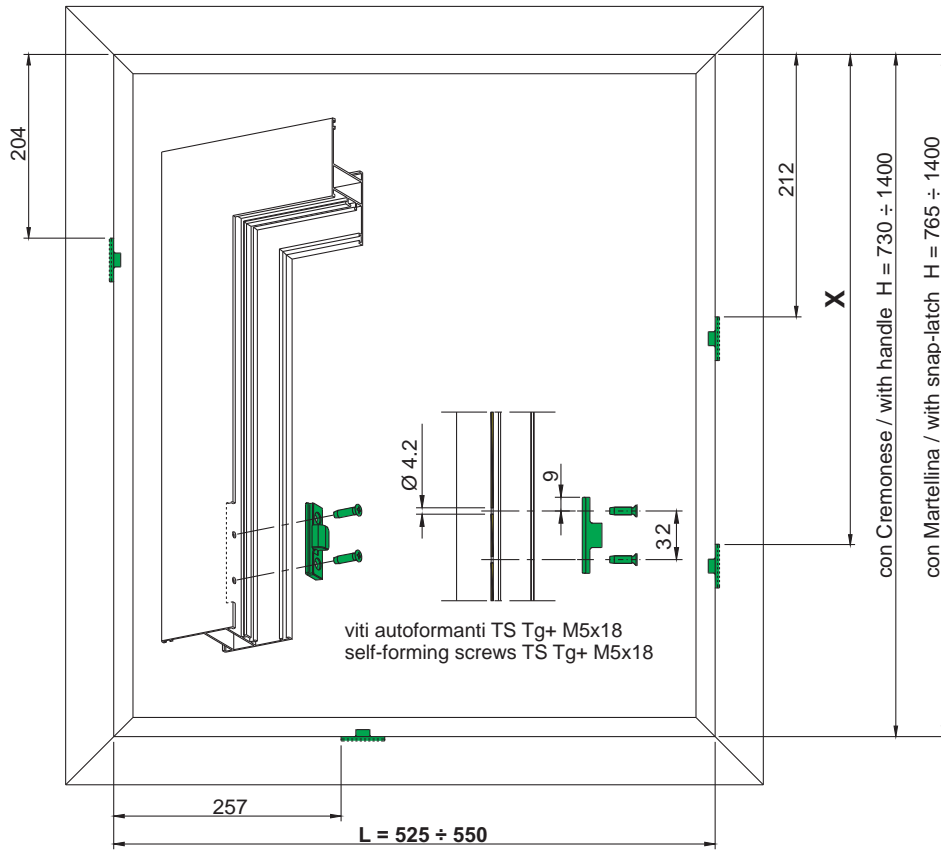

H	X mm
(730-765)÷830	438
831÷1030	638
1031÷1230	838
1231÷1400	1038

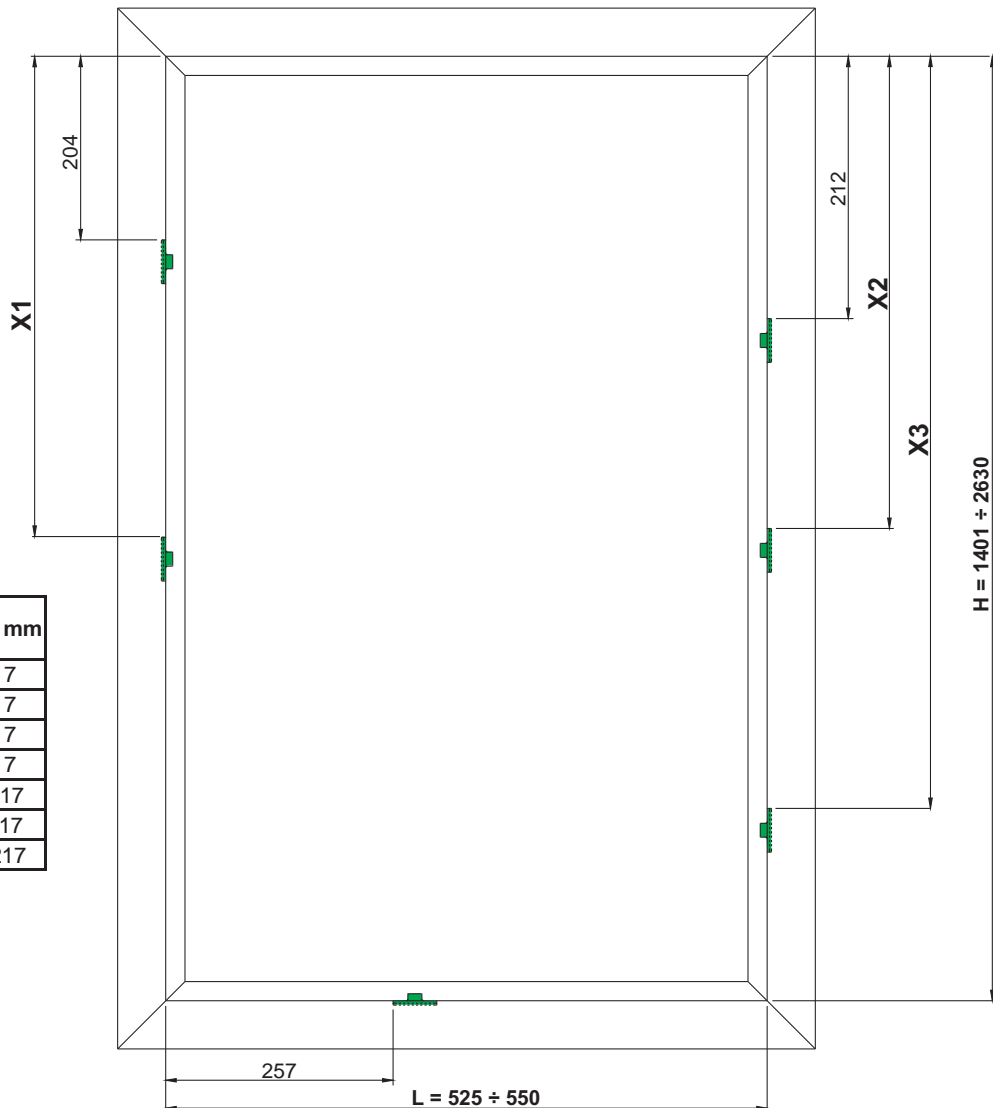

H	X1 mm
1401÷1500	617
1501÷1700	717
1701÷1900	817
1901÷2100	917
2101÷2300	1017
2301÷2500	1117
2501÷2630	1217

H	X2 mm
1401÷1430	625
1431÷1630	725
1631÷1830	825
1831÷2030	925
2031÷2230	1025
2231÷2430	1125
2431÷2630	1225

H	X3 mm
1401÷1430	1038
1431÷1630	1238
1631÷1830	1438
1831÷2030	1638
2031÷2230	1838
2231÷2430	2038
2431÷2630	2238

POSIZIONAMENTO KIT ROSTRI SU TELAIO FISSO (DESTRO) - ANTI-BURGLAR DEVICE POSITIONING ON FIXED FRAME (RH)

Per il posizionamento degli accessori sull'anta vedere pag. 28/29 - For accessories positioning on leaf, see page 28/29

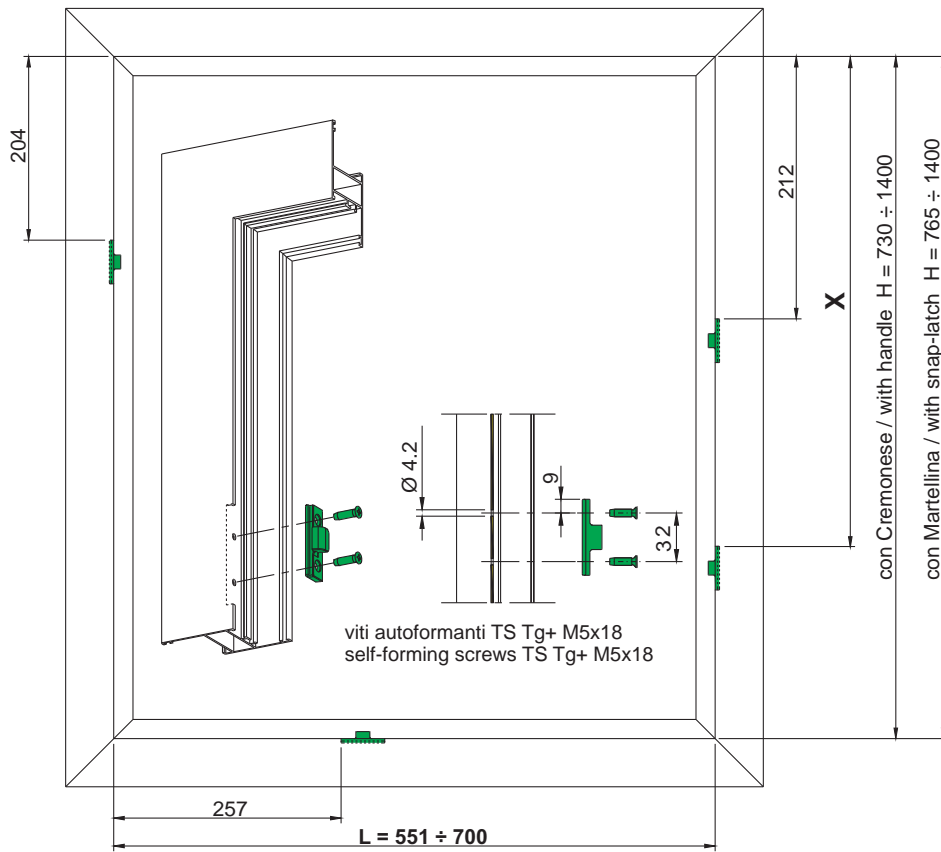

H	X mm
(730-765)÷830	438
831÷1030	638
1031÷1230	838
1231÷1400	1038

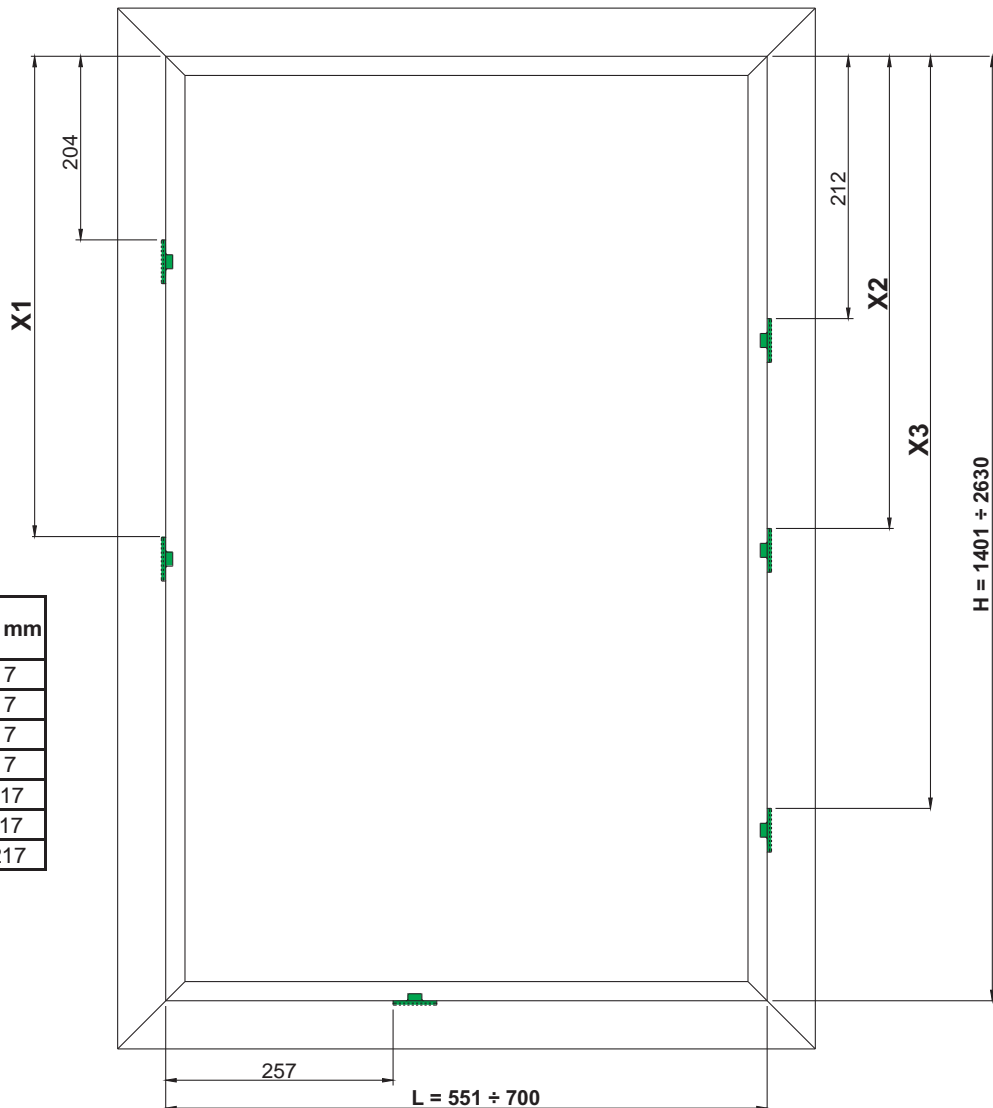

H	X2 mm
1401÷1430	625
1431÷1630	725
1631÷1830	825
1831÷2030	925
2031÷2230	1025
2231÷2430	1125
2431÷2630	1225

H	X1 mm
1401÷1500	617
1501÷1700	717
1701÷1900	817
1901÷2100	917
2101÷2300	1017
2301÷2500	1117
2501÷2630	1217

H	X3 mm
1401÷1430	1038
1431÷1630	1238
1631÷1830	1438
1831÷2030	1638
2031÷2230	1838
2231÷2430	2038
2431÷2630	2238

POSIZIONAMENTO KIT ROSTRI SU TELAIO FISSO (DESTRO) - ANTI-BURGLAR DEVICE POSITIONING ON FIXED FRAME (RH)

Per il posizionamento degli accessori sull'anta vedere pag. 30/31 - For accessories positioning on leaf, see page 30/31

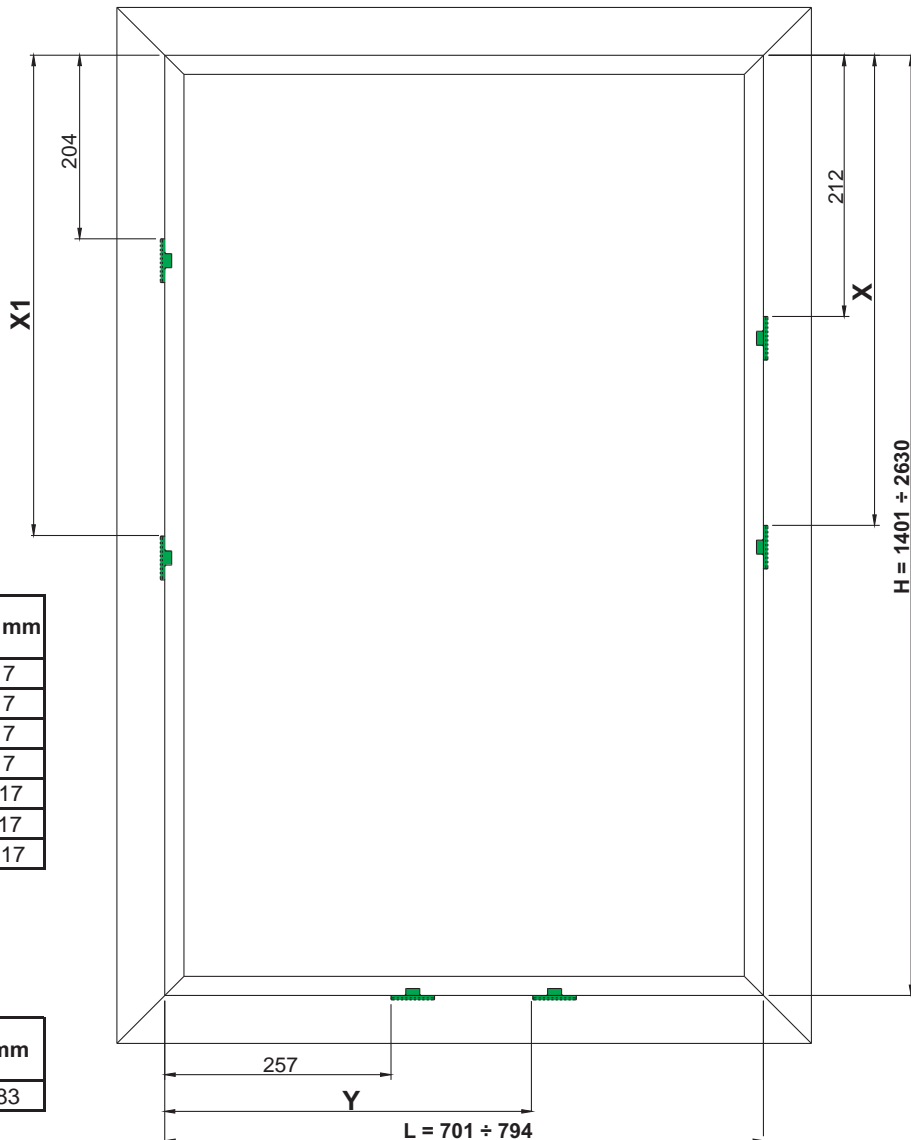
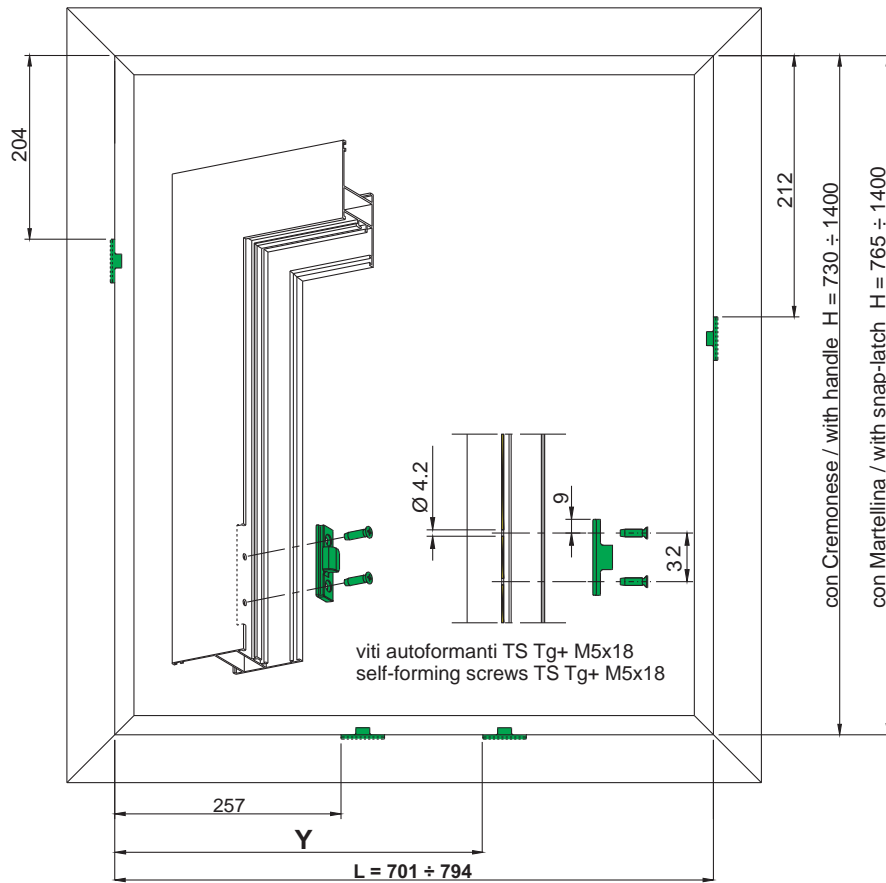

POSIZIONAMENTO KIT ROSTRI SU TELAIO FISSO (DESTRO) - ANTI-BURGLAR DEVICE POSITIONING ON FIXED FRAME (RH)

Per il posizionamento degli accessori sull'anta vedere pag. 32/33 - For accessories positioning on leaf, see page 32/33

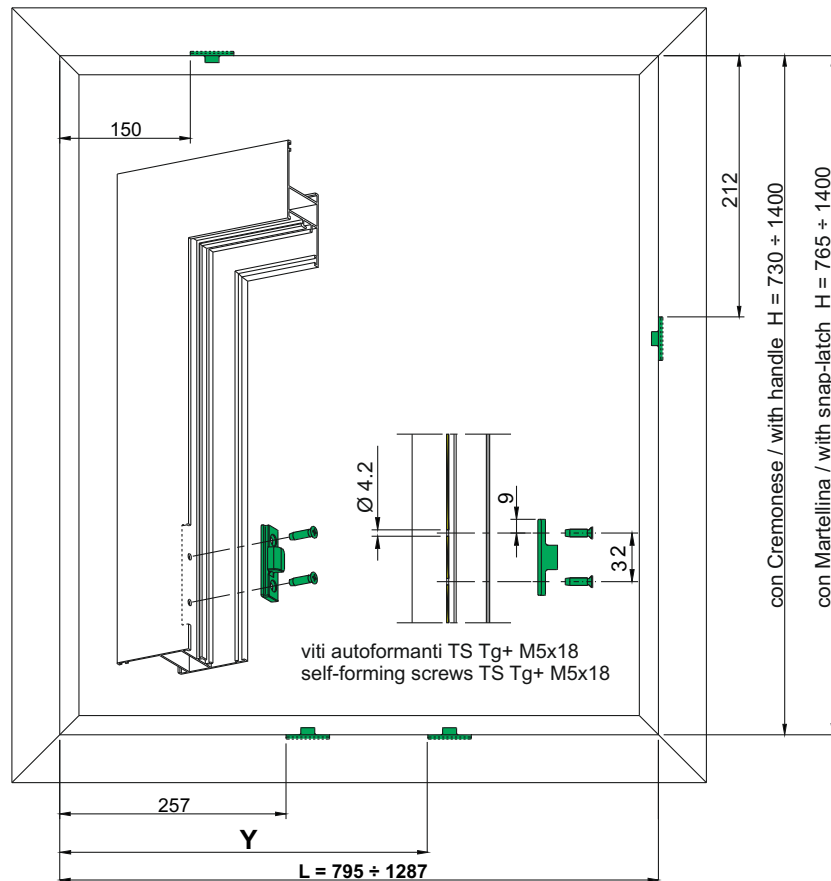

L	Y mm
795+900	483
901+1100	683
1101+1287	883

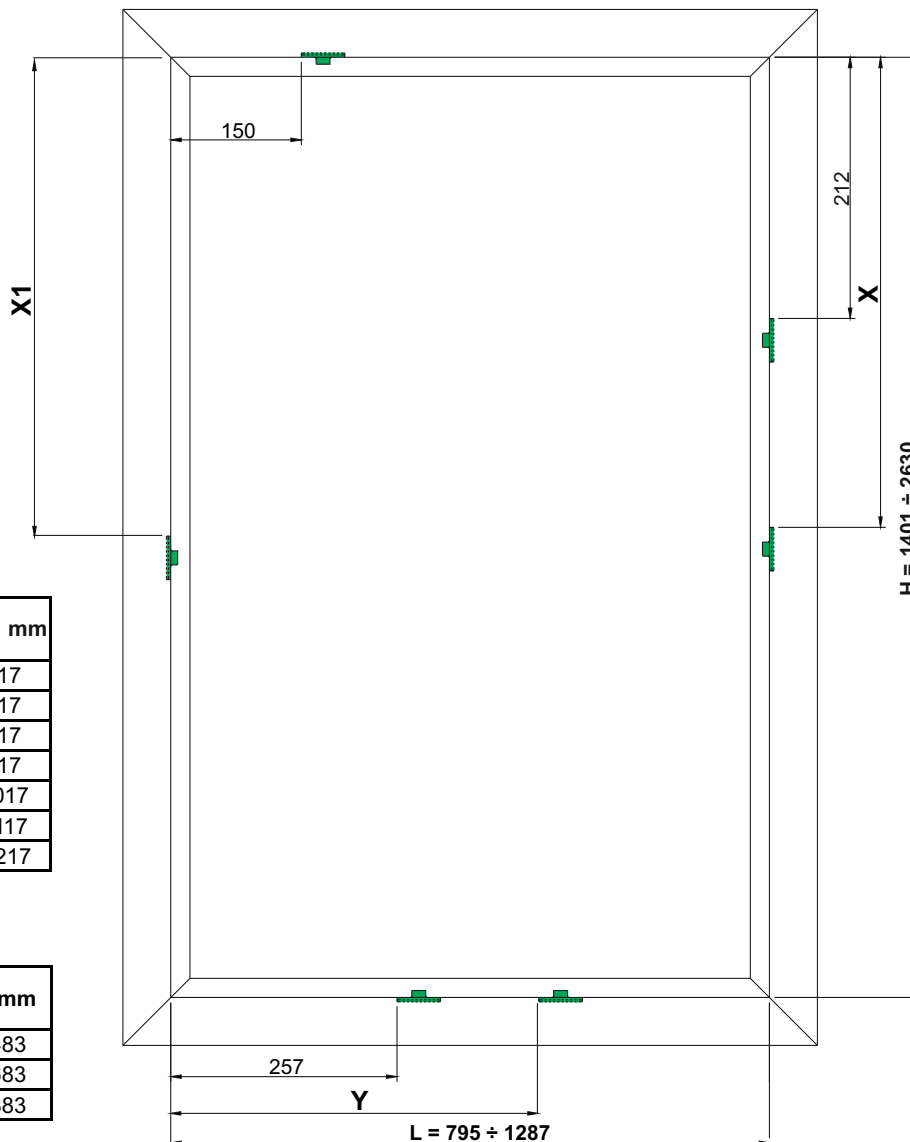

H	X mm
1401+1530	638
1531+1930	838
1931+2330	1038
2331+2630	1238

H	X1 mm
1401+1500	617
1501+1700	717
1701+1900	817
1901+2100	917
2101+2300	1017
2301+2500	1117
2501+2630	1217

L	Y mm
795+900	483
901+1100	683
1101+1287	883

POSIZIONAMENTO KIT ROSTRI SU TELAIO FISSO (DESTRO) - ANTI-BURGLAR DEVICE POSITIONING ON FIXED FRAME (RH)

Per il posizionamento degli accessori sull'anta vedere pag. 34/35 - For accessories positioning on leaf, see page 34/35

L	Y1 mm
1288÷1300	663

L	Y mm
1288÷1300	883

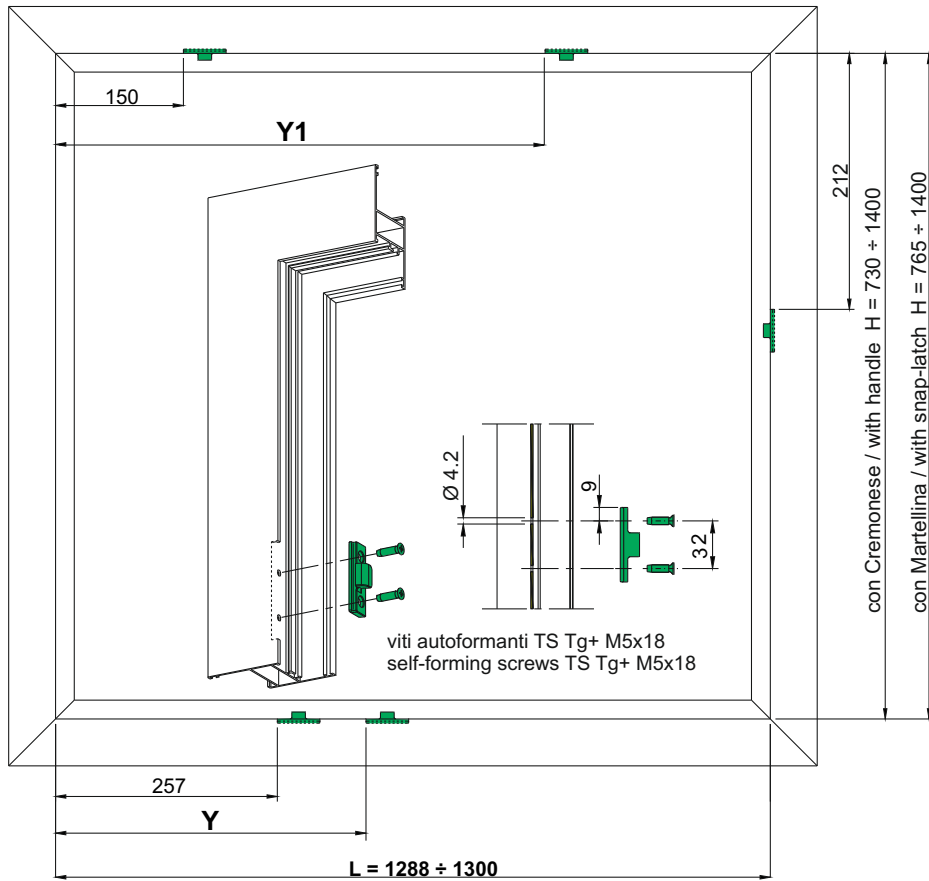

L	Y1 mm
1288÷1300	663

H	X mm
1401+1530	638
1531+1930	838
1931+2330	1038
2331+2630	1238

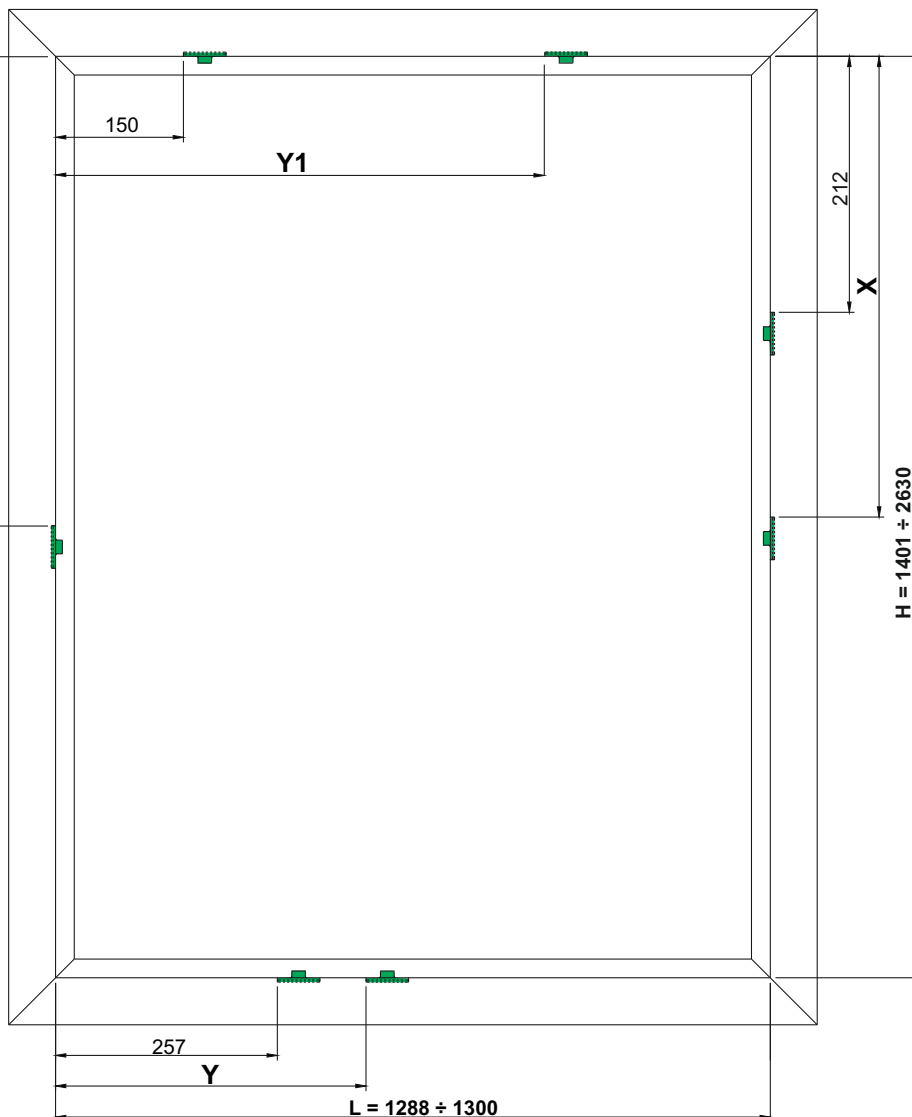

H	X1 mm
1401÷1500	617
1501÷1700	717
1701÷1900	817
1901÷2100	917
2101÷2300	1017
2301÷2500	1117
2501÷2630	1217

L	Y mm
1288÷1300	883

POSIZIONAMENTO KIT ROSTRI SU TELAIO FISSO (DESTRO) - ANTI-BURGLAR DEVICE POSITIONING ON FIXED FRAME (RH)

Per il posizionamento degli accessori sull'anta vedere pag. 36/37 - For accessories positioning on leaf, see page 36/37

L	Y1 mm
1301+1487	663
1488+1687	763
1688+1700	863

L	Y2 mm
1301+1500	670
1501+1700	770

L	Y3 mm
1301+1500	1083
1501+1700	1283

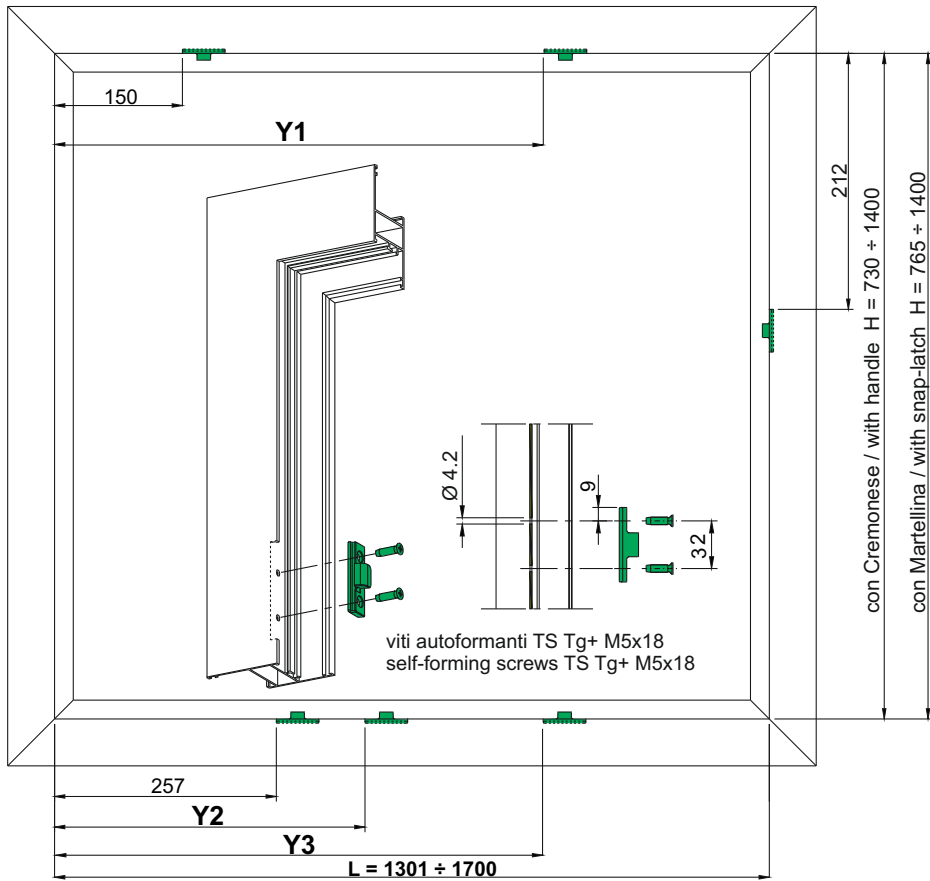

L	Y1 mm
1301+1487	663
1488+1687	763
1688+1700	863

H	X1 mm
1401+1500	617
1501+1700	717
1701+1900	817
1901+2100	917
2101+2300	1017
2301+2500	1117
2501+2630	1217

H	X mm
1401+1530	638
1531+1930	838
1931+2330	1038
2331+2630	1238

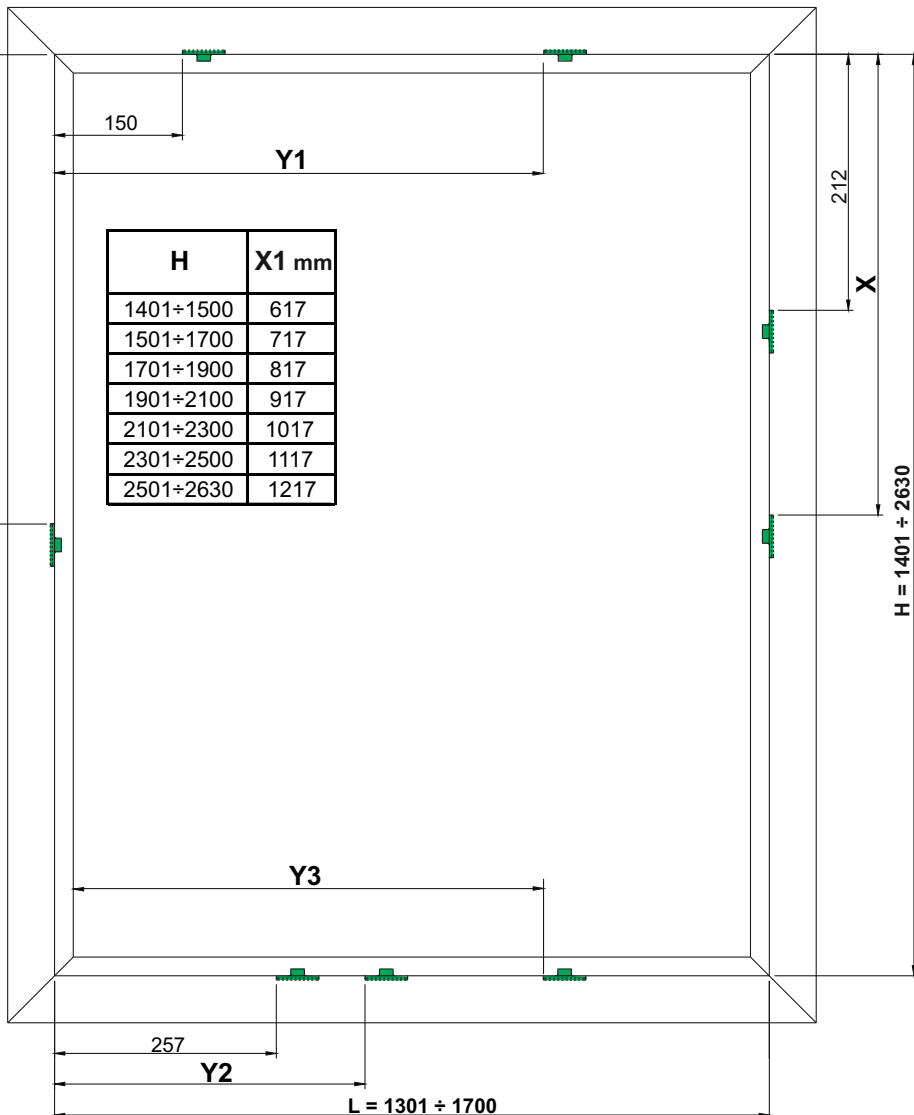

L	Y2 mm
1301+1500	670
1501+1700	770

L	Y3 mm
1301+1500	1083
1501+1700	1283

Lavorazione aste - Rods machining

lavorazione per rostri di sicurezza
anti-burglar device machining

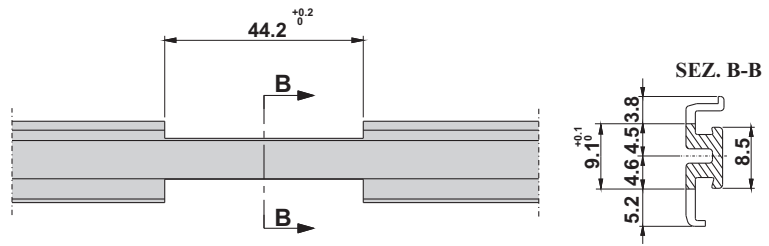

L > 795 mm

asta di trasmissione
transmission rod

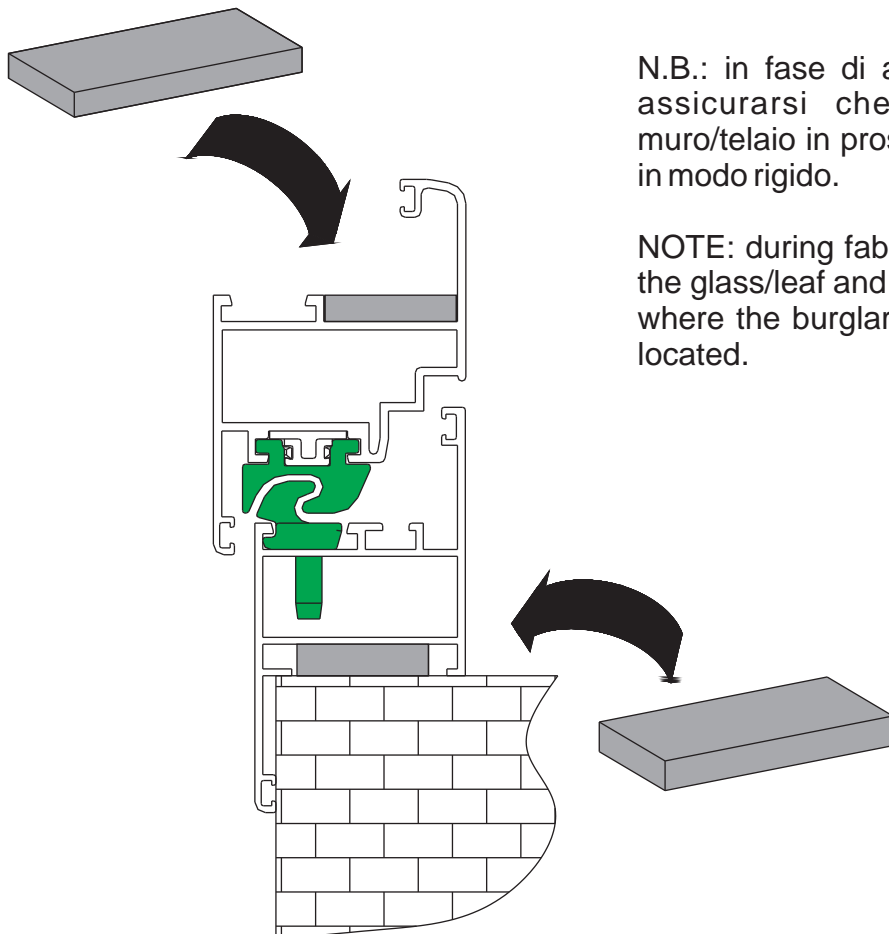
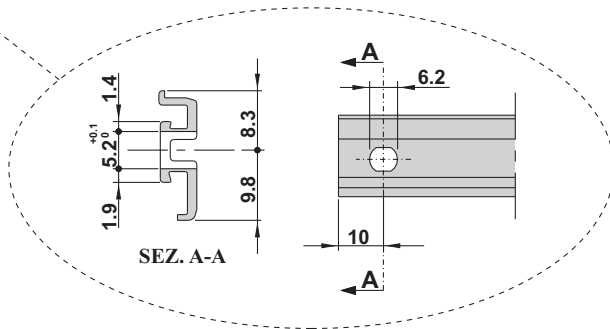
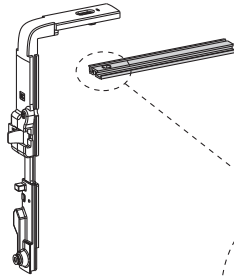
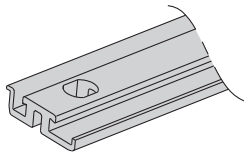

N.B.: in fase di assemblaggio del serramento assicurarsi che il sistema vetro/anta e muro/telaio in prossimità dei rostri, sia vincolato in modo rigido.

NOTE: during fabrication of the window, ensure the glass/leaf and wall/frame profiles are in-filled where the burglar resistance locking points are located.

FISSAGGIO TELAIO FISSO (DESTRO) - RH FIXED FRAME FASTENING

L = 440 ÷ 700

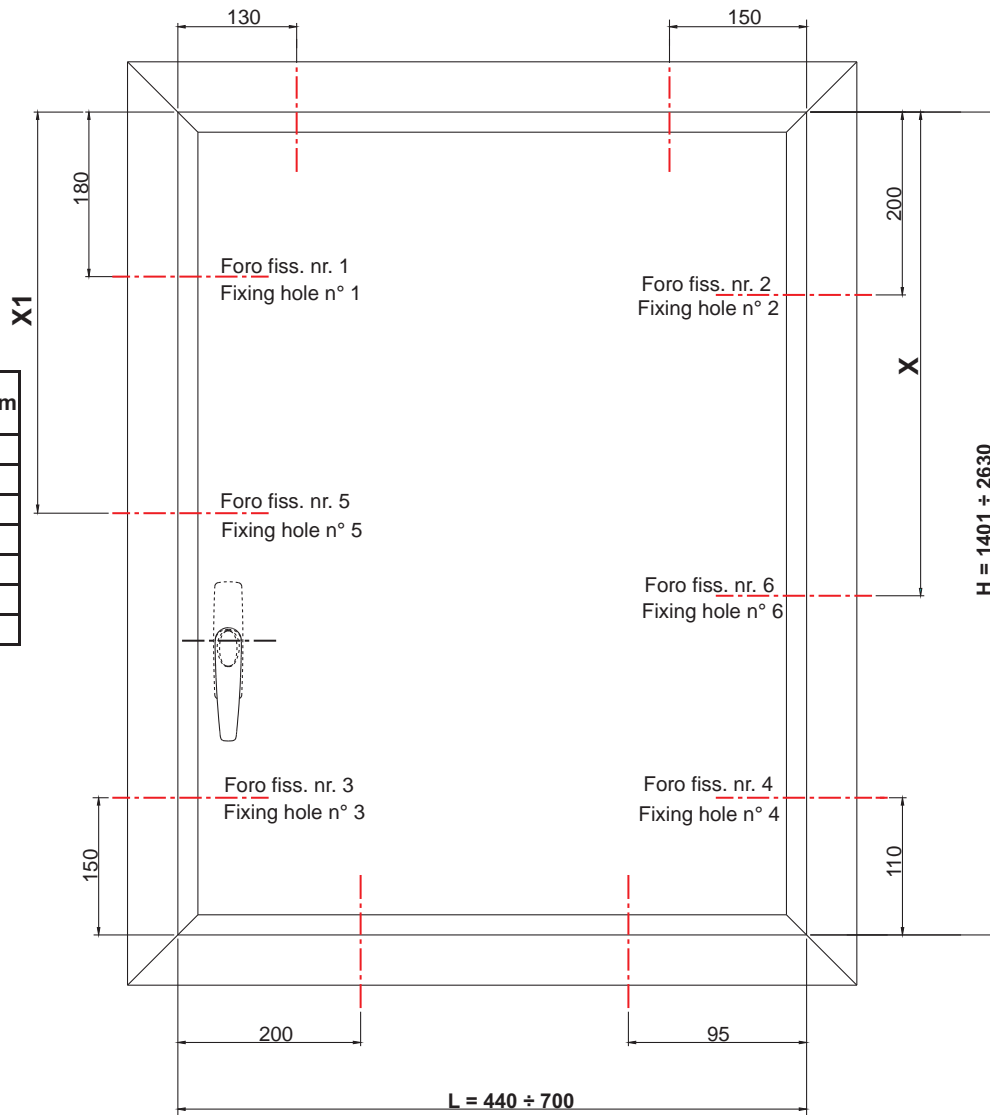
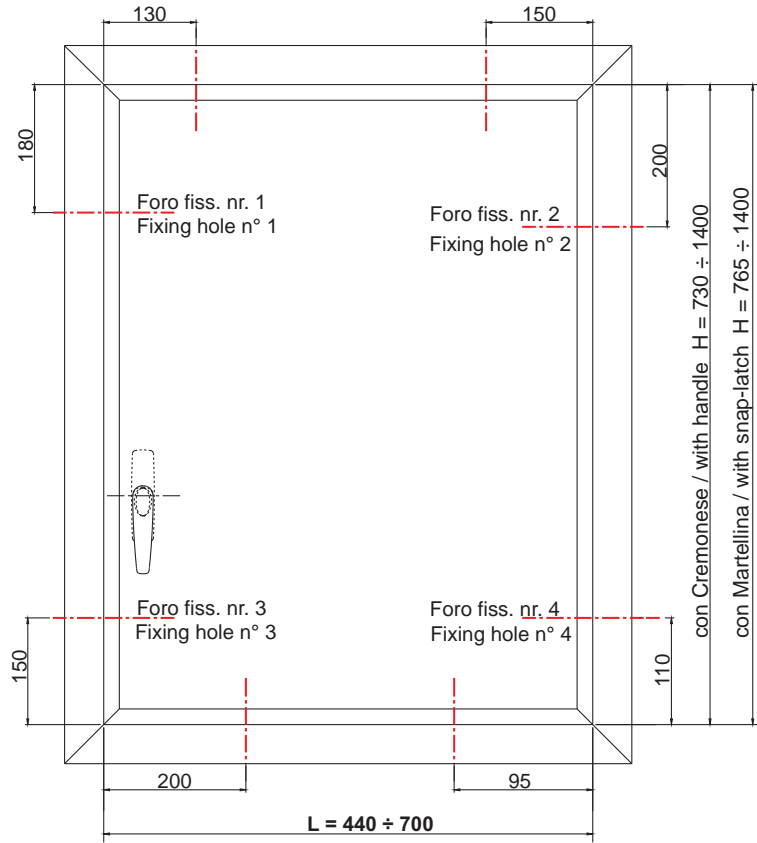

H	X1 mm
1401÷1500	700
1501÷1700	800
1701÷1900	900
1901÷2100	1000
2101÷2300	1100
2301÷2500	1200
2501÷2630	1300

H	X mm
1401÷1430	710
1431÷1630	810
1631÷1830	910
1831÷2030	1010
2031÷2230	1110
2231÷2430	1210
2431÷2630	1310

FISSAGGIO TELAIO FISSO (DESTRO) - RH FIXED FRAME FASTENING

L = 701 ÷ 1300

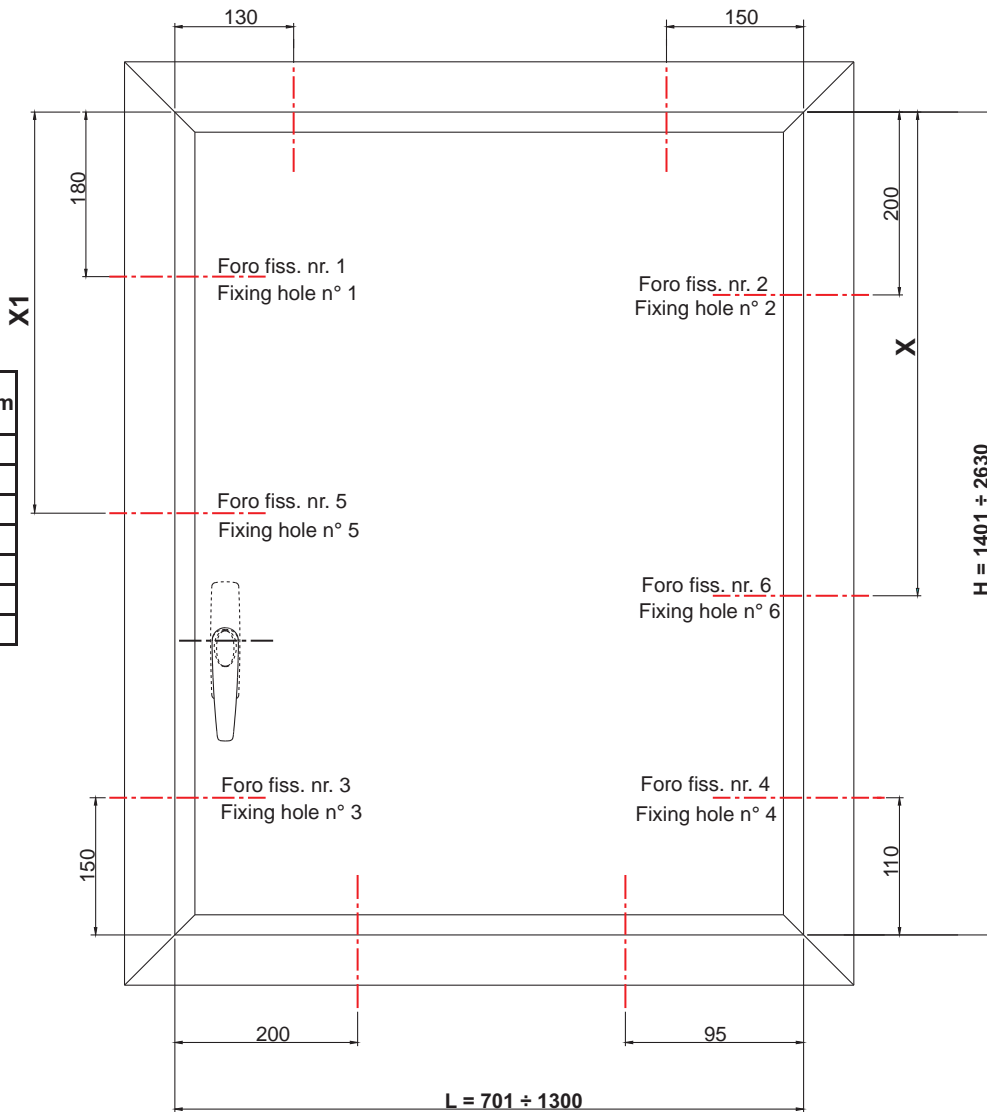
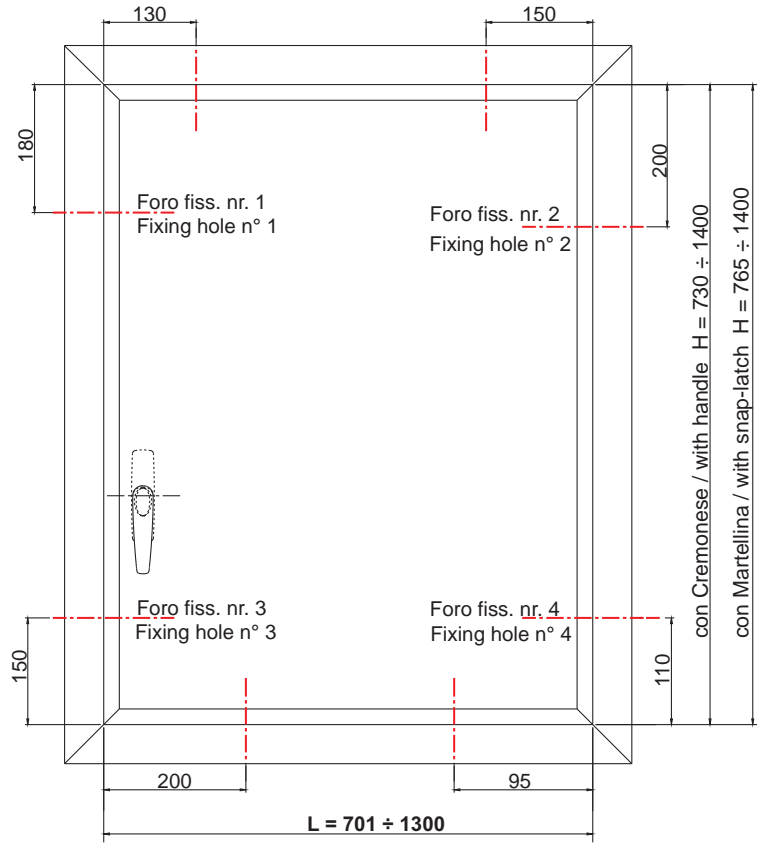

H	X1 mm
1401÷1500	700
1501÷1700	800
1701÷1900	900
1901÷2100	1000
2101÷2300	1100
2301÷2500	1200
2501÷2630	1300

H	X mm
1401÷1530	710
1531÷1730	810
1731÷1930	910
1931÷2130	1010
2131÷2330	1110
2331÷2530	1210
2531÷2630	1310

L = 1301 ÷ 1700

L	Y mm
1301÷1487	750
1488÷1687	850
1688÷1700	950

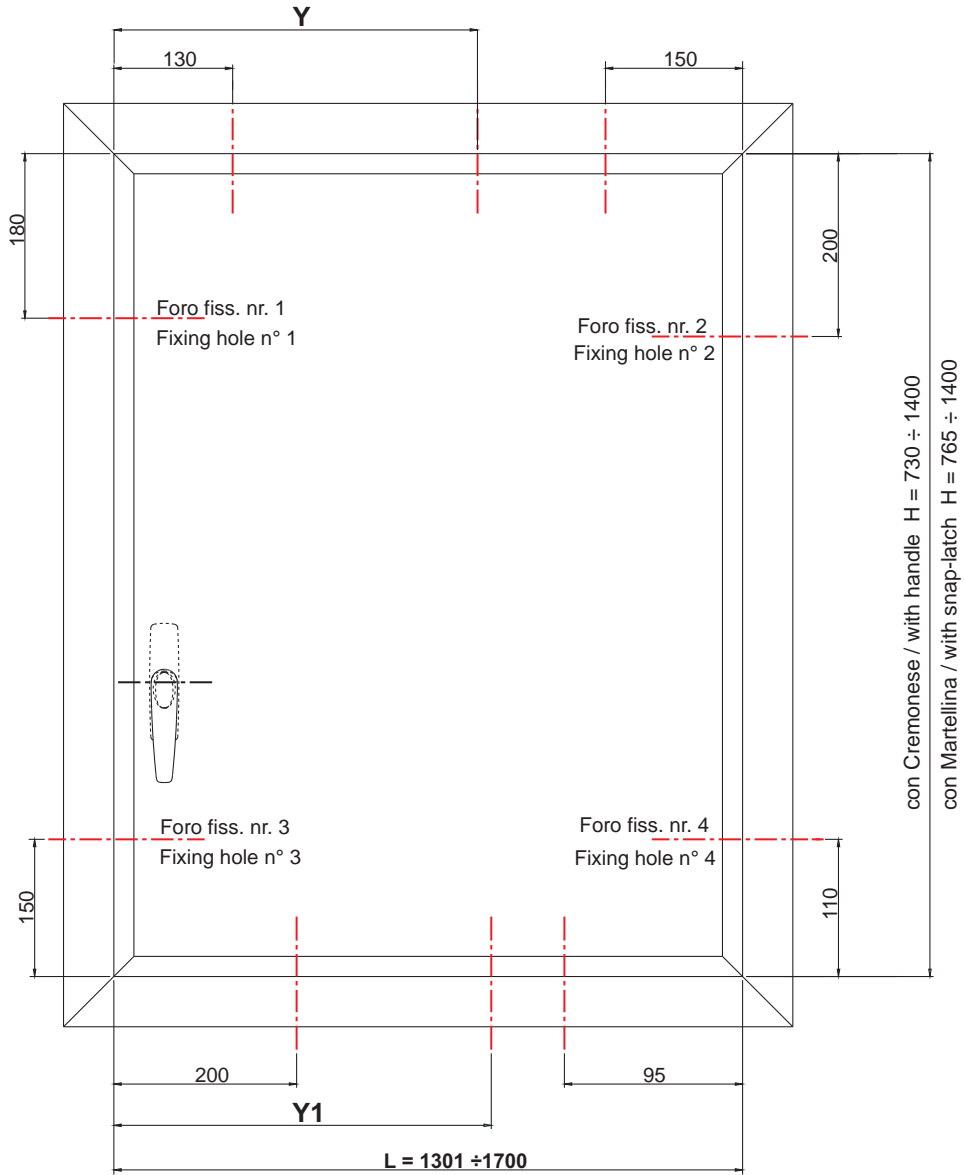

L	Y1 mm
1301÷1500	750
1501÷1700	850

FISSAGGIO TELAIO FISSO (DESTRO) - RH FIXED FRAME FASTENING

L = 1301 ÷ 1700

L	Y mm
1301÷1487	750
1488÷1687	850
1688÷1700	950

H	X1 mm
1401÷1500	700
1501÷1700	800
1701÷1900	900
1901÷2100	1000
2101÷2300	1100
2301÷2500	1200
2501÷2630	1300

H	X mm
1401÷1530	710
1531÷1730	810
1731÷1930	910
1931÷2130	1010
2131÷2330	1110
2331÷2530	1210
2531÷2630	1310

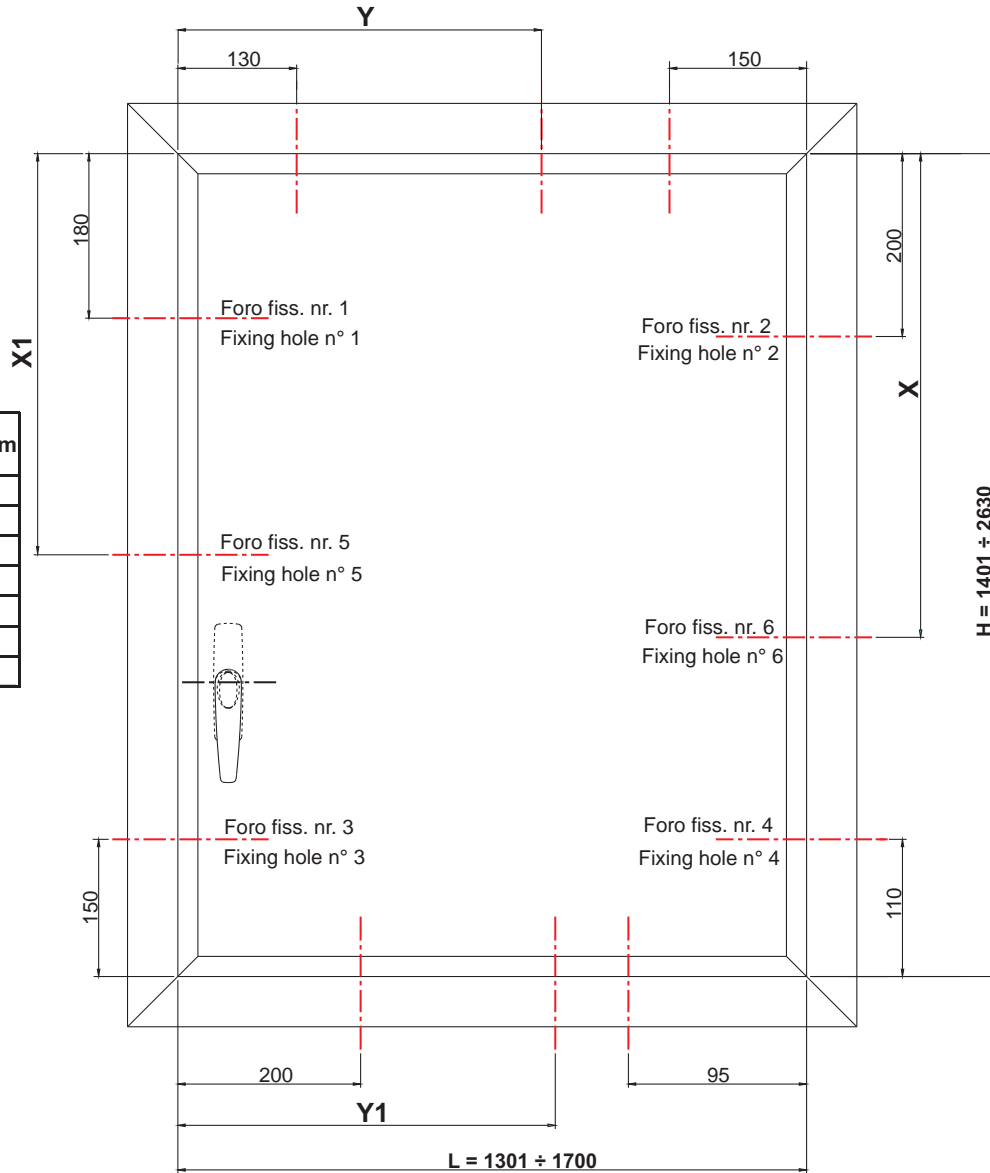

L	Y1 mm
1301÷1500	750
1501÷1700	850

I**(A) L=440 ÷ 524****H=730 ÷ 1400****(B) L=440 ÷ 524****H=765 ÷ 1400****A = cremonese / handle****B = martellina / snap-latch**

H	Asta Rod mm	Codice Code
730/765÷900	400	A1D
901÷1100	600	A2D
1101÷1300	800	A3D
1301÷1400	1000	A4D

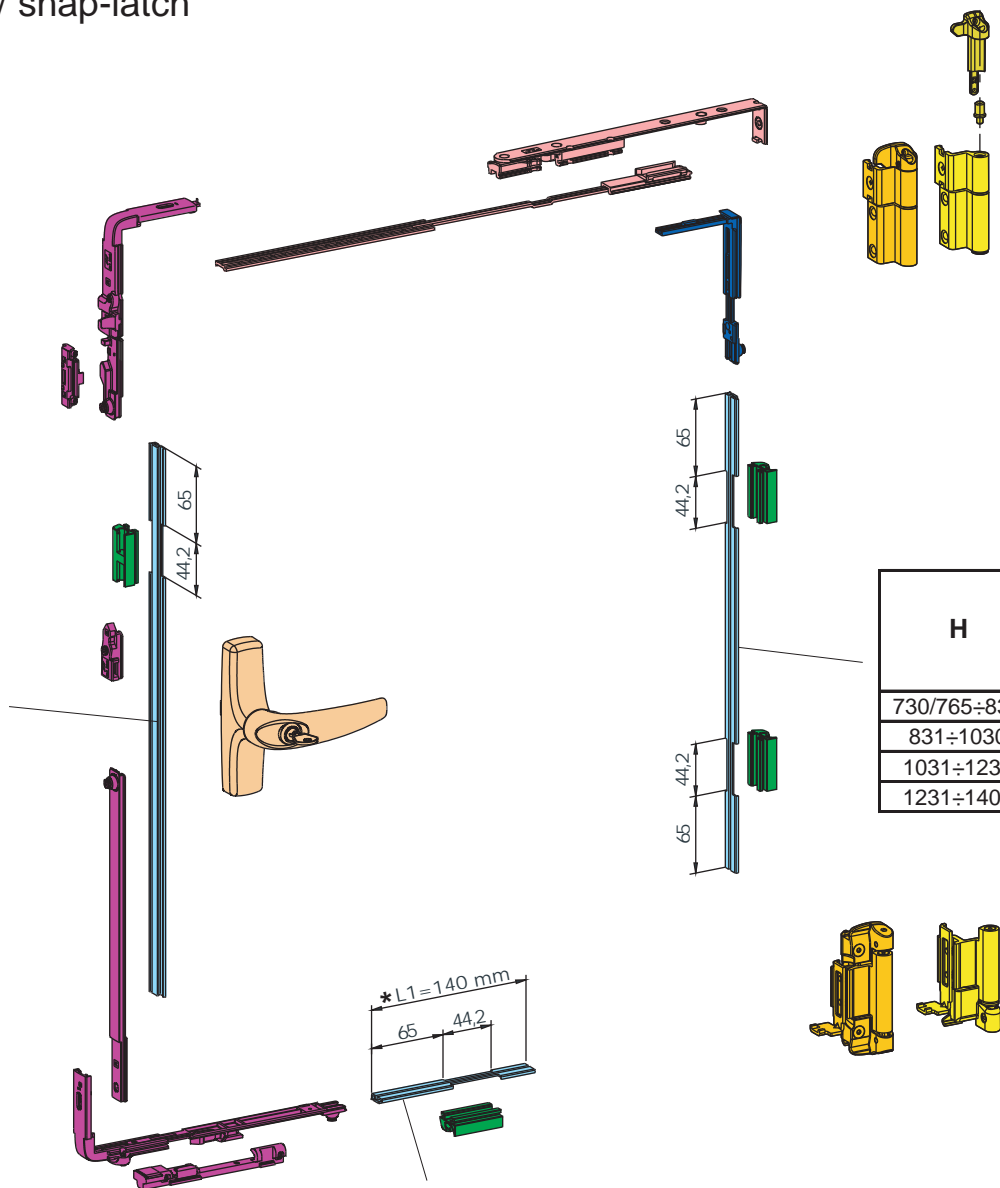

H	Asta Rod mm	Codice Code
730/765÷830	400	A9
831÷1030	600	A10
1031÷1230	800	A11
1231÷1400	1000	A29

L	Asta Rod mm	Codice Code
440÷524	250	A8D

* N.B.: Tagliare astina A8D a 140 mm
 Note: Cut A8D rod to 140 mm

Per il posizionamento degli accessori sul telaio vedere pag. 12 - For accessories positioning on frame, see page 12

H	Asta Rod mm	Codice Code
1401÷1500	1000	A5D
1501÷1700	1200	A6D
1701÷1900	1400	A7D
1901÷2100	1600	A14D
2101÷2300	1800	A15D
2301÷2500	2000	A16D
2501÷2700	2200	A17D

H	Asta Rod mm	Codice Code
1401÷1430	1000	A12
1431÷1630	1200	A13
1631÷1830	1400	A30
1831÷2030	1600	A31
2031÷2230	1800	A32
2231÷2430	2000	A33
2431÷2630	2200	A34

H	X mm
1401÷1430	564
1431÷1630	664
1631÷1830	764
1831÷2030	864
2031÷2230	964
2231÷2430	1064
2431÷2630	1164

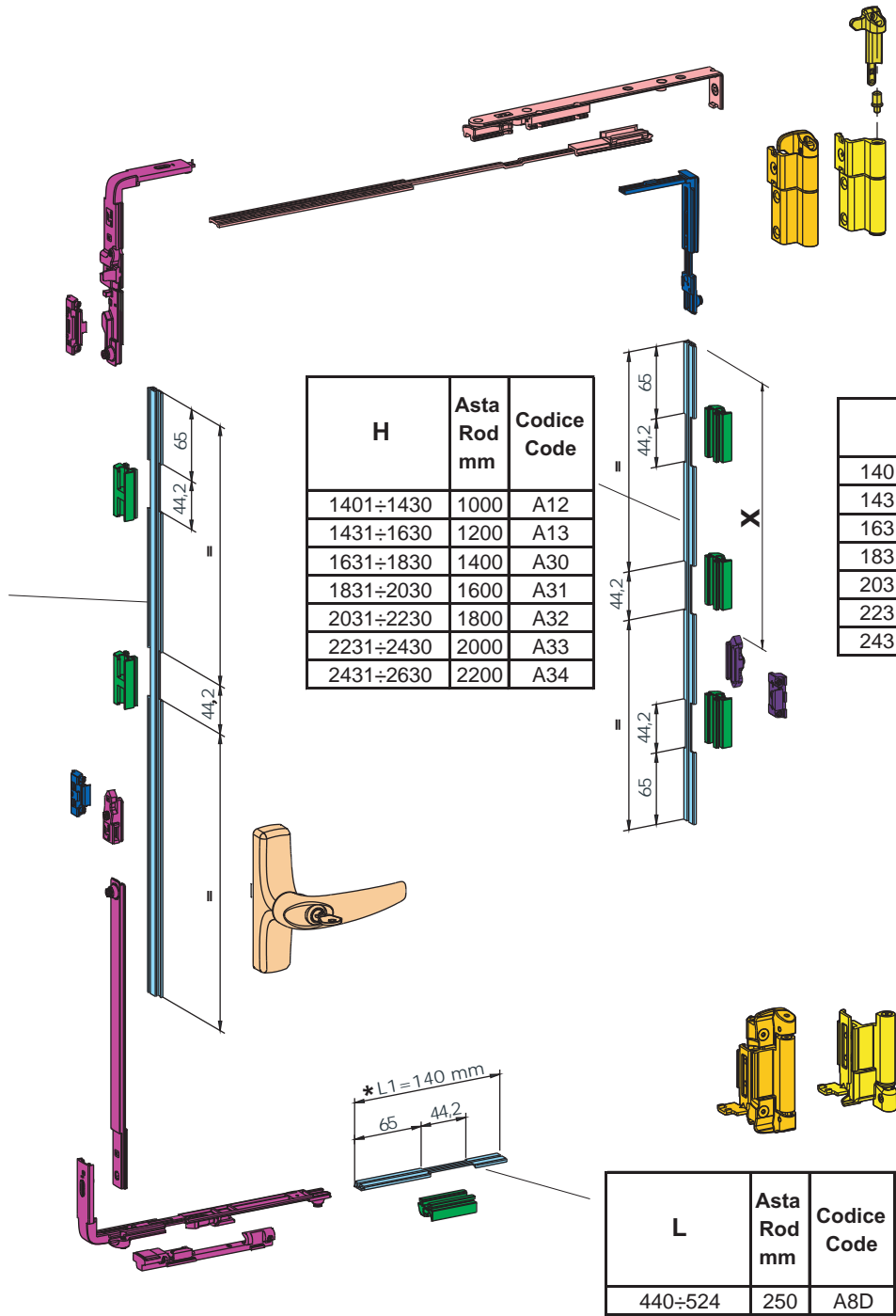

* N.B.: Tagliare astina A8D a 140 mm
 * Note: Cut A8D rod to 140 mm

Per il posizionamento degli accessori sul telaio vedere pag. 12 - For accessories positioning on frame, see page 12

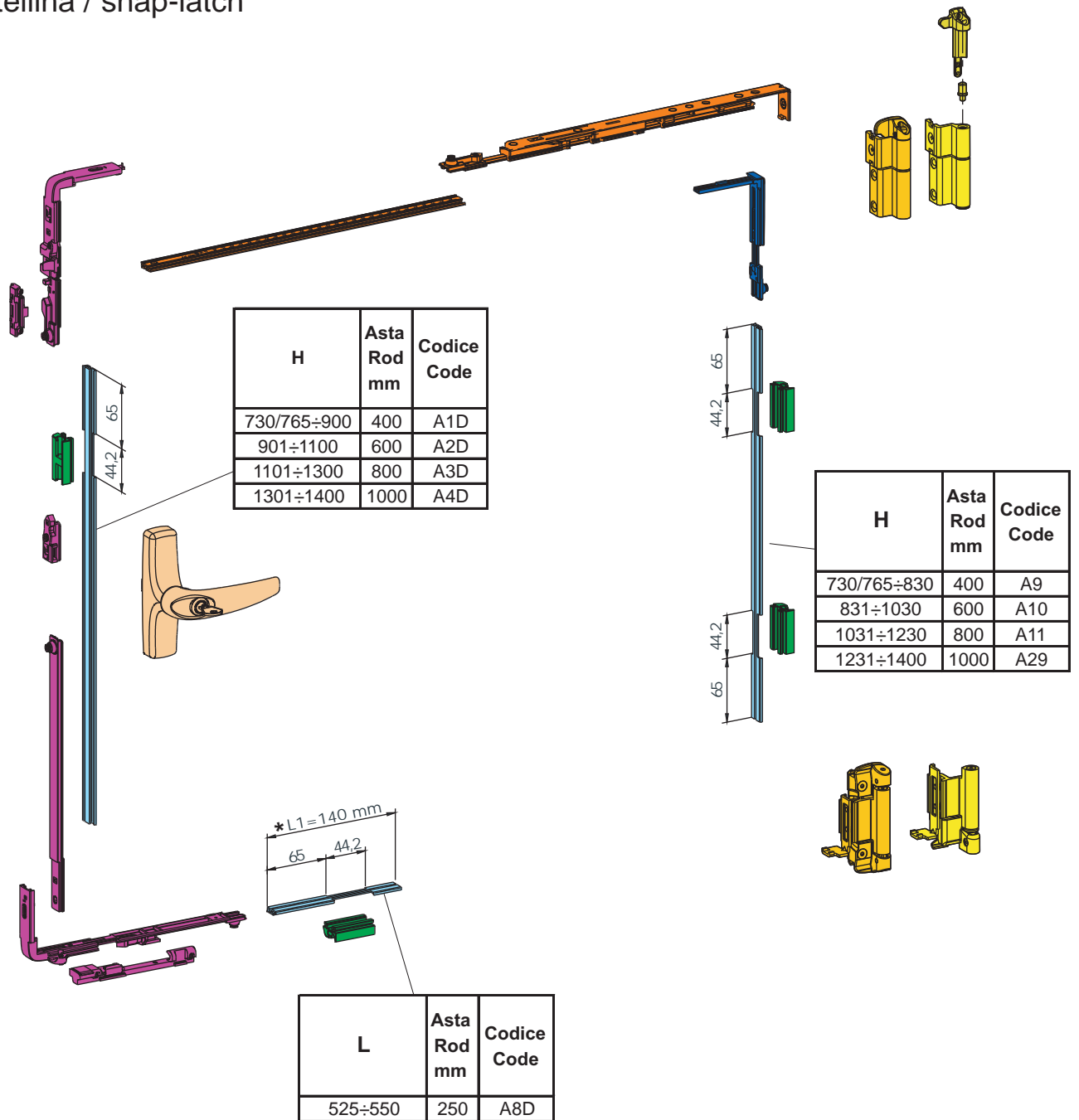
I**(A) L=525 ÷ 550****H=730 ÷ 1400****(B) L=525 ÷ 550****H=765 ÷ 1400****A = cremonese / handle****B = martellina / snap-latch**

* N.B.: Tagliare astina A8D a 140 mm
 * Note: Cut A8D rod to 140 mm

Per il posizionamento degli accessori sul telaio vedere pag. 13 - For accessories positioning on frame, see page 13

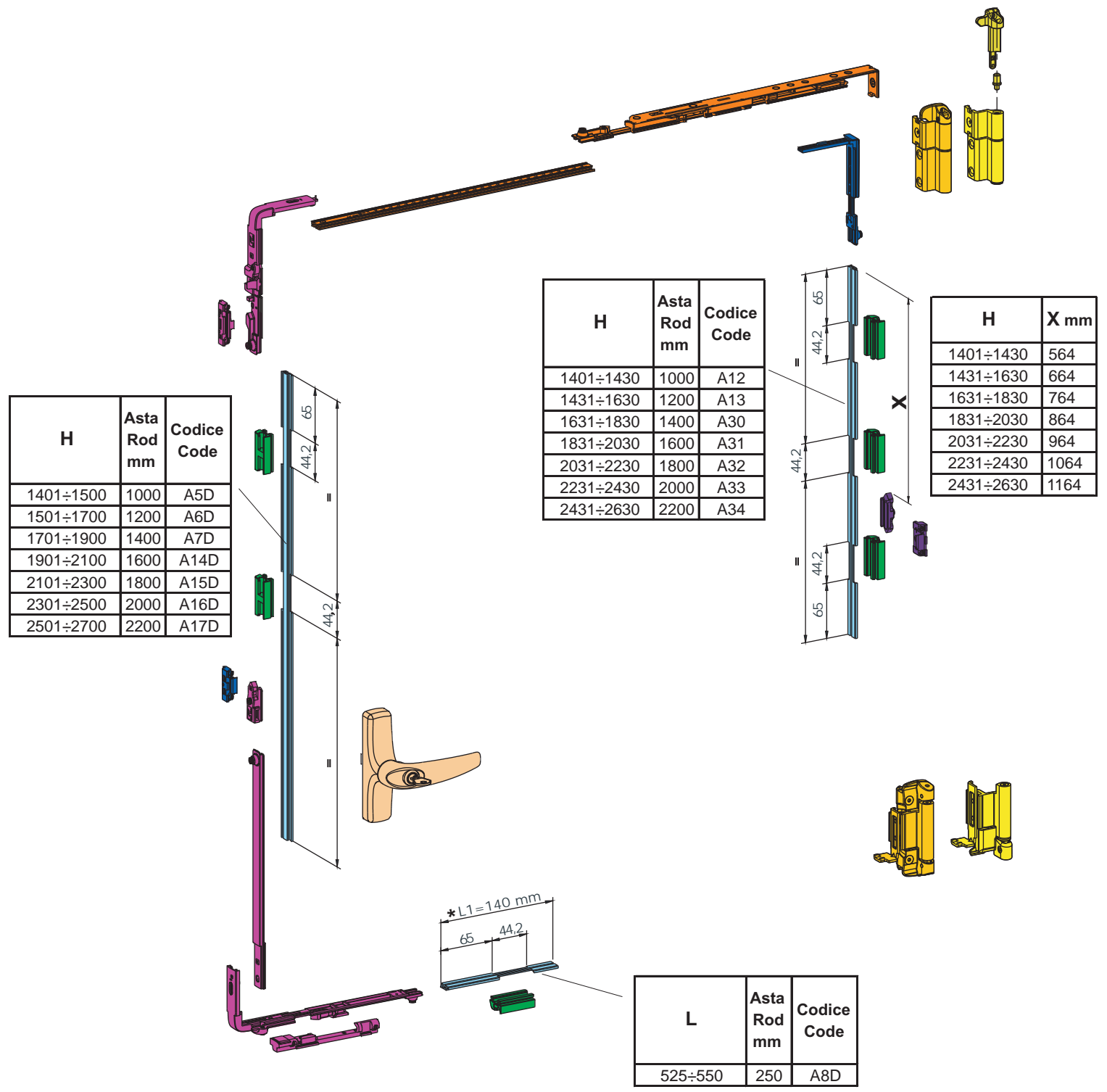

H	Asta Rod mm	Codice Code
1401÷1500	1000	A5D
1501÷1700	1200	A6D
1701÷1900	1400	A7D
1901÷2100	1600	A14D
2101÷2300	1800	A15D
2301÷2500	2000	A16D
2501÷2700	2200	A17D

H	Asta Rod mm	Codice Code
1401÷1430	1000	A12
1431÷1630	1200	A13
1631÷1830	1400	A30
1831÷2030	1600	A31
2031÷2230	1800	A32
2231÷2430	2000	A33
2431÷2630	2200	A34

H	X mm
1401÷1430	564
1431÷1630	664
1631÷1830	764
1831÷2030	864
2031÷2230	964
2231÷2430	1064
2431÷2630	1164

L	Asta Rod mm	Codice Code
525÷550	250	A8D

* N.B.: Tagliare astina A8D a 140 mm
 Note: Cut A8D rod to 140 mm

Per il posizionamento degli accessori sul telaio vedere pag. 13 - For accessories positioning on frame, see page 13

(A) L=551 ÷ 700

H=730 ÷ 1400

(B) L=551 ÷ 700

H=765 ÷ 1400

A = cremonese / handle
B = martellina / snap-latch

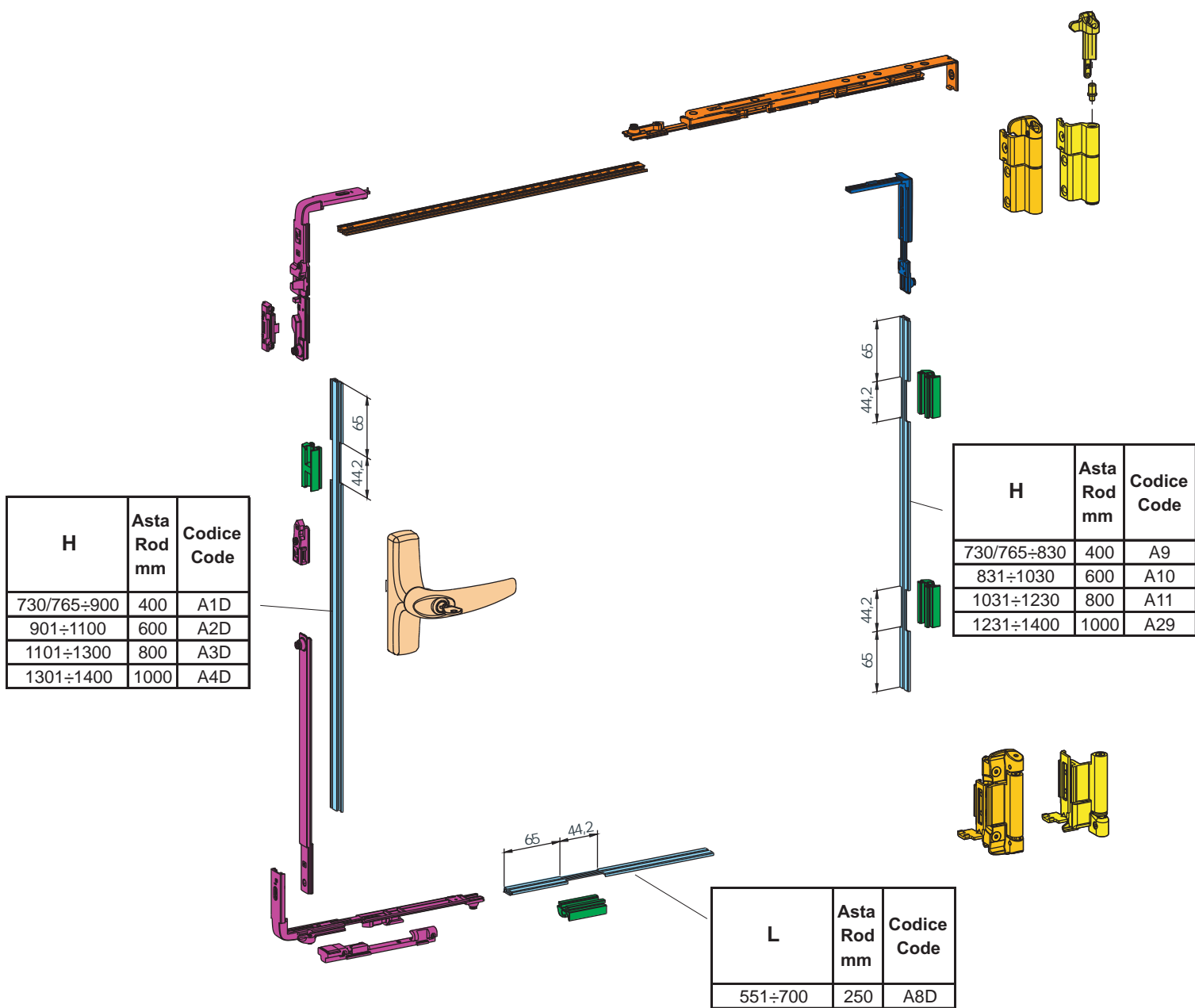

Per il posizionamento degli accessori sul telaio vedere pag. 14 - For accessories positioning on frame, see page 14

The diagram shows a window frame assembly with various accessories. The main frame is shown in blue, with accessories in purple, orange, and yellow. Dimensions are indicated: 65 mm for the top and bottom offsets, and 44.2 mm for the vertical spacing between accessories. A central table lists the height (H) ranges, the corresponding Asta Rod mm, and the Codice Code. To the right, another table lists the height (H) ranges and the corresponding X mm dimension. At the bottom, a table lists the length (L) range, the corresponding Asta Rod mm, and the Codice Code. A door handle is also shown in orange.

H	Asta Rod mm	Codice Code
1401÷1500	1000	A5D
1501÷1700	1200	A6D
1701÷1900	1400	A7D
1901÷2100	1600	A14D
2101÷2300	1800	A15D
2301÷2500	2000	A16D
2501÷2700	2200	A17D

H	X mm
1401÷1430	564
1431÷1630	664
1631÷1830	764
1831÷2030	864
2031÷2230	964
2231÷2430	1064
2431÷2630	1164

L	Asta Rod mm	Codice Code
551÷700	250	A8D

Per il posizionamento degli accessori sul telaio vedere pag. 14 - For accessories positioning on frame, see page 14

(A) L=701 ÷ 794

H=730 ÷ 1400

(B) L=701 ÷ 794

H=765 ÷ 1400

A = cremonese / handle

B = martellina / snap-latch

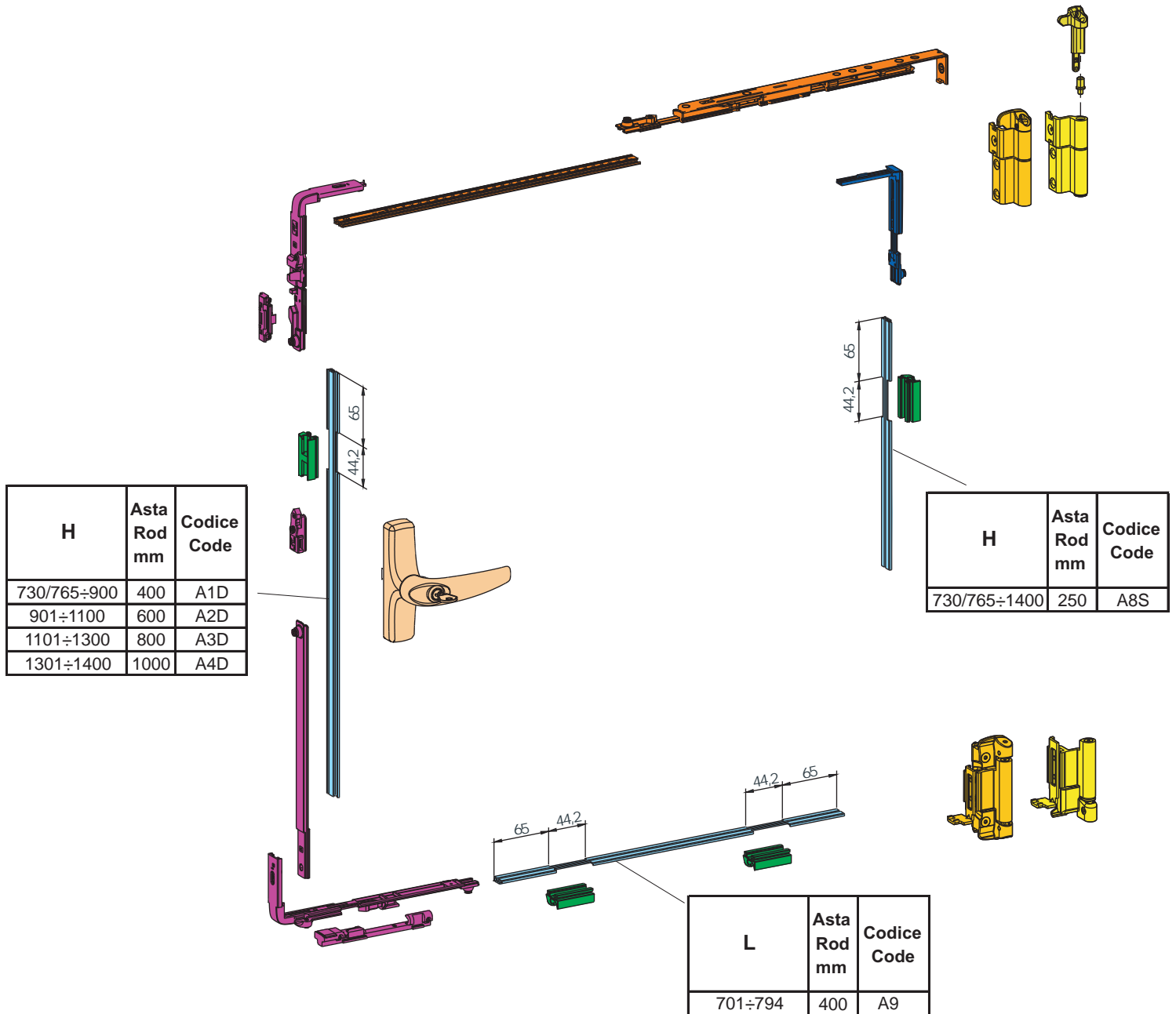

Per il posizionamento degli accessori sul telaio vedere pag. 15 - For accessories positioning on frame, see page 15

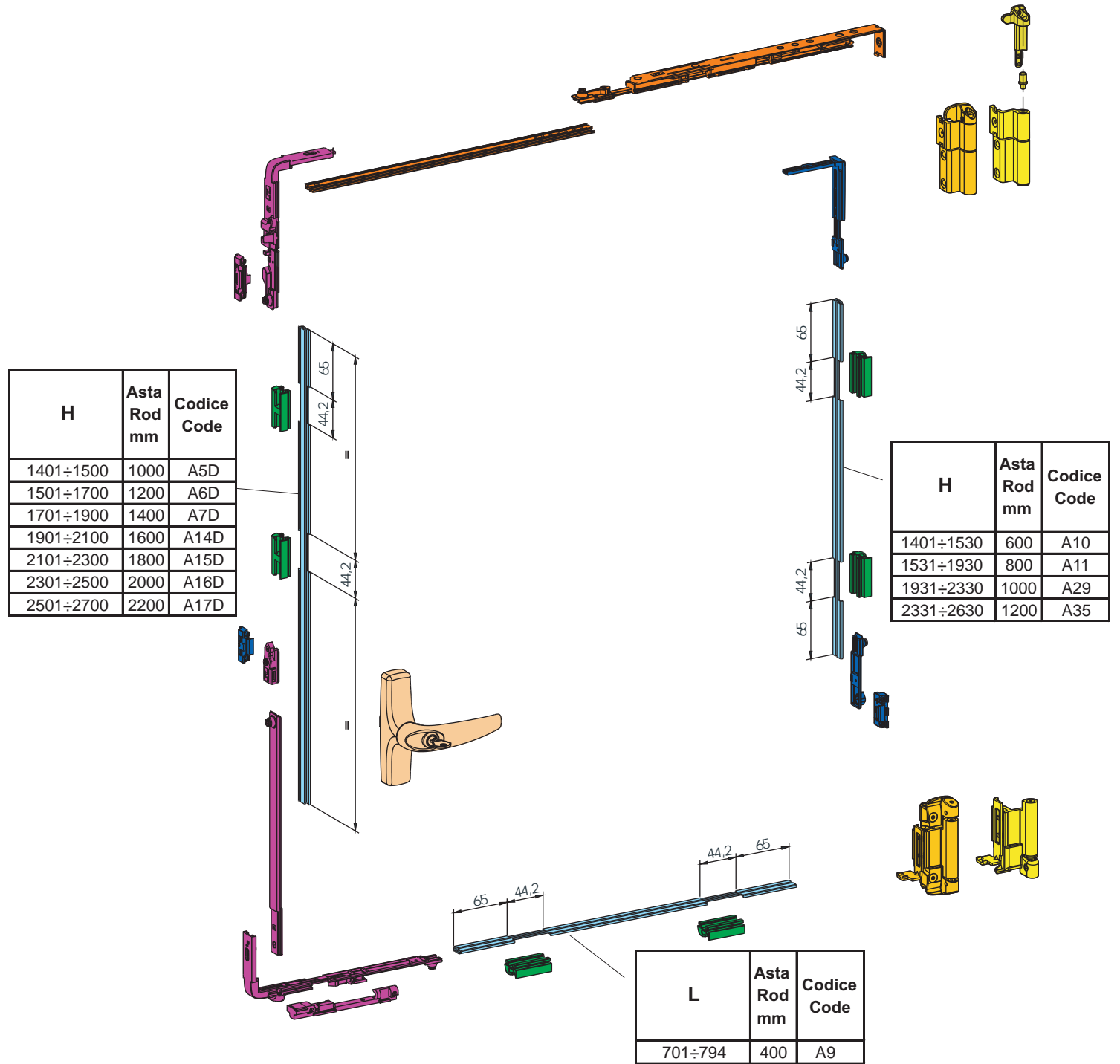

Per il posizionamento degli accessori sul telaio vedere pag. 15 - For accessories positioning on frame, see page 15

(A) L=795 ÷ 1287

H=730 ÷ 1400

(B) L=795 ÷ 1287

H=765 ÷ 1400

A = cremonese / handle
 B = martellina / snap-latch

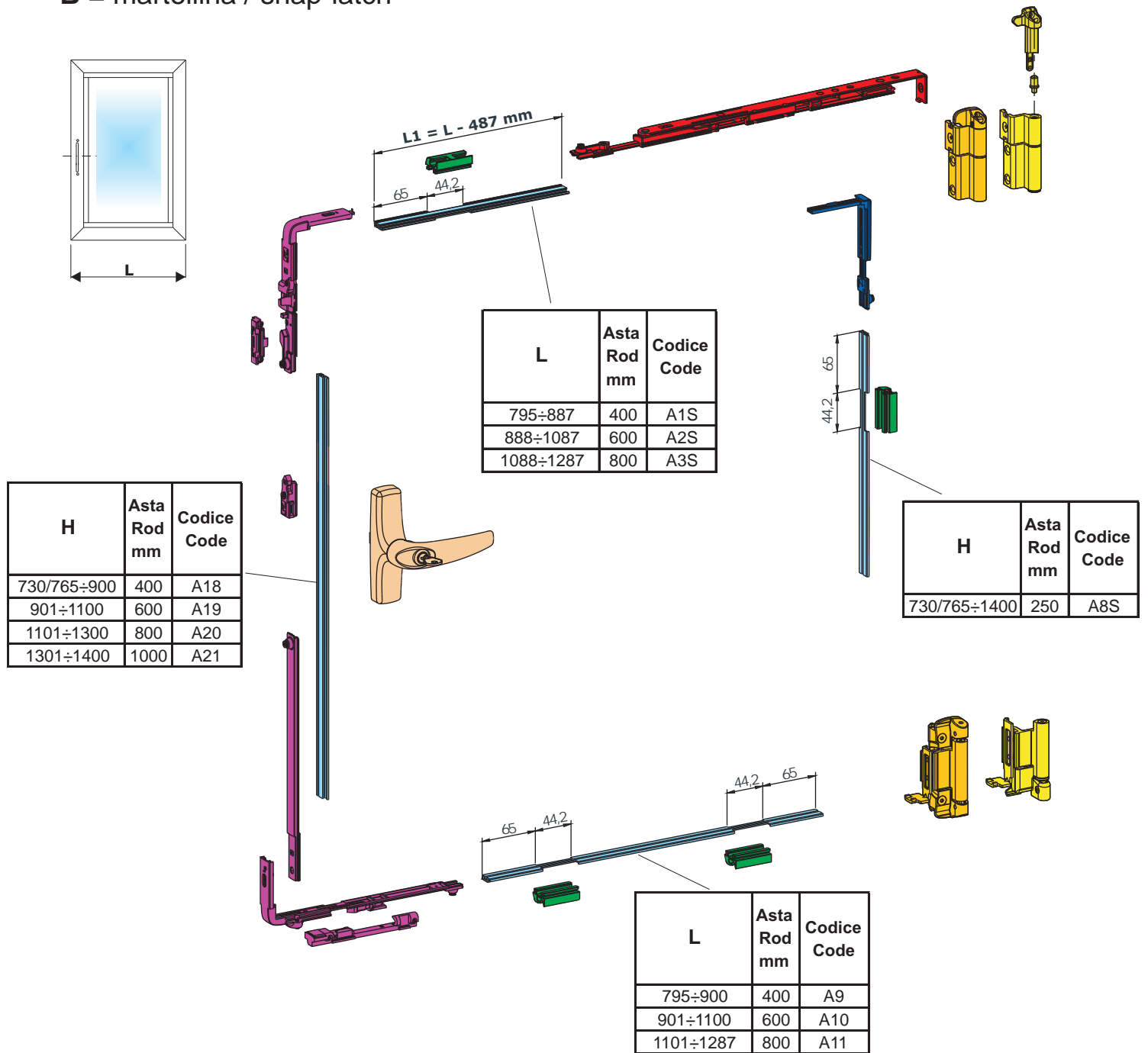

Per il posizionamento degli accessori sul telaio vedere pag. 16 - For accessories positioning on frame, see page 16

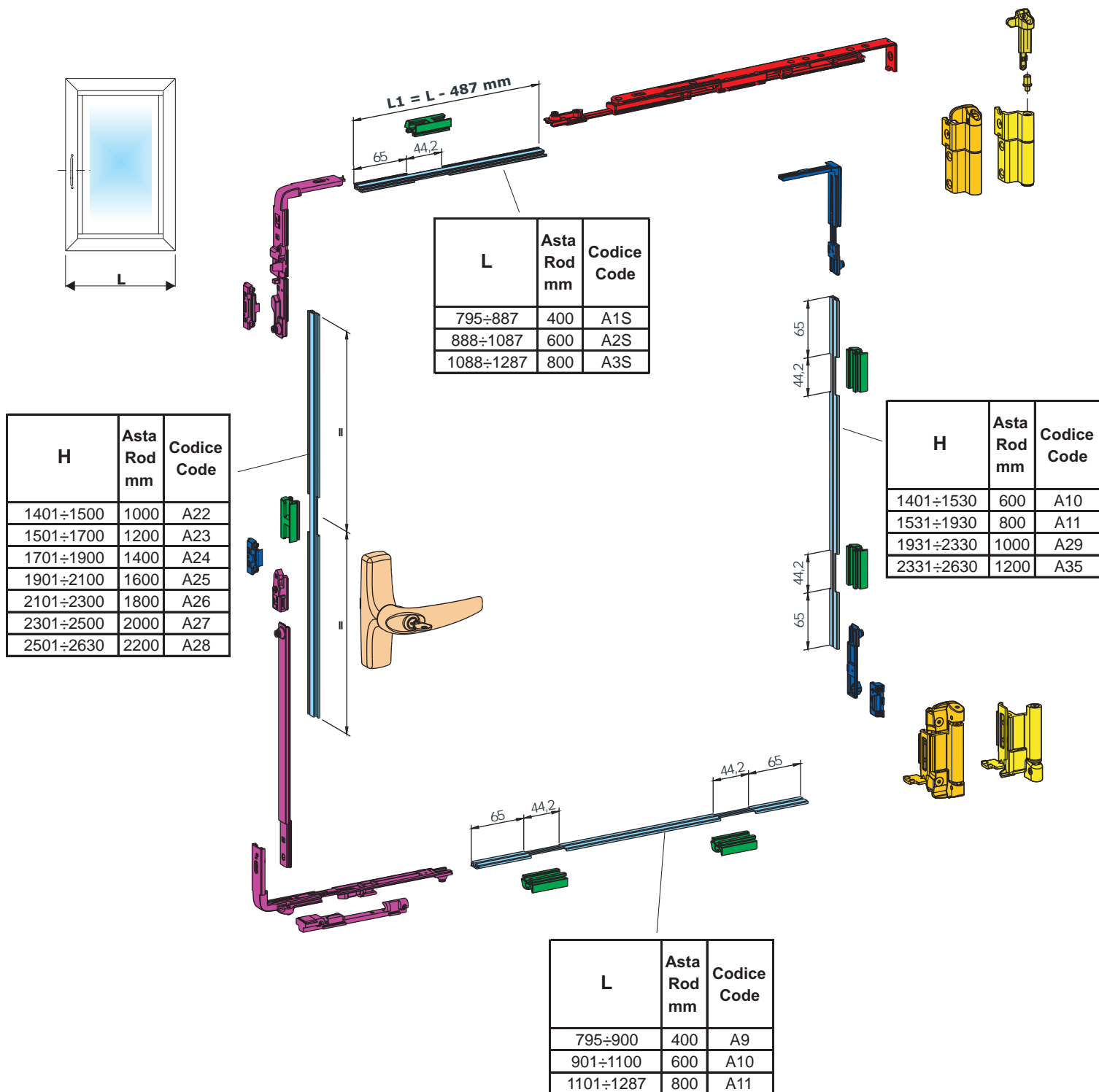

Per il posizionamento degli accessori sul telaio vedere pag. 16 - For accessories positioning on frame, see page 16

(A) L=1288 ÷ 1300

H=730 ÷ 1400

(B) L=1288 ÷ 1300

H=765 ÷ 1400

A = cremonese / handle
 B = martellina / snap-latch

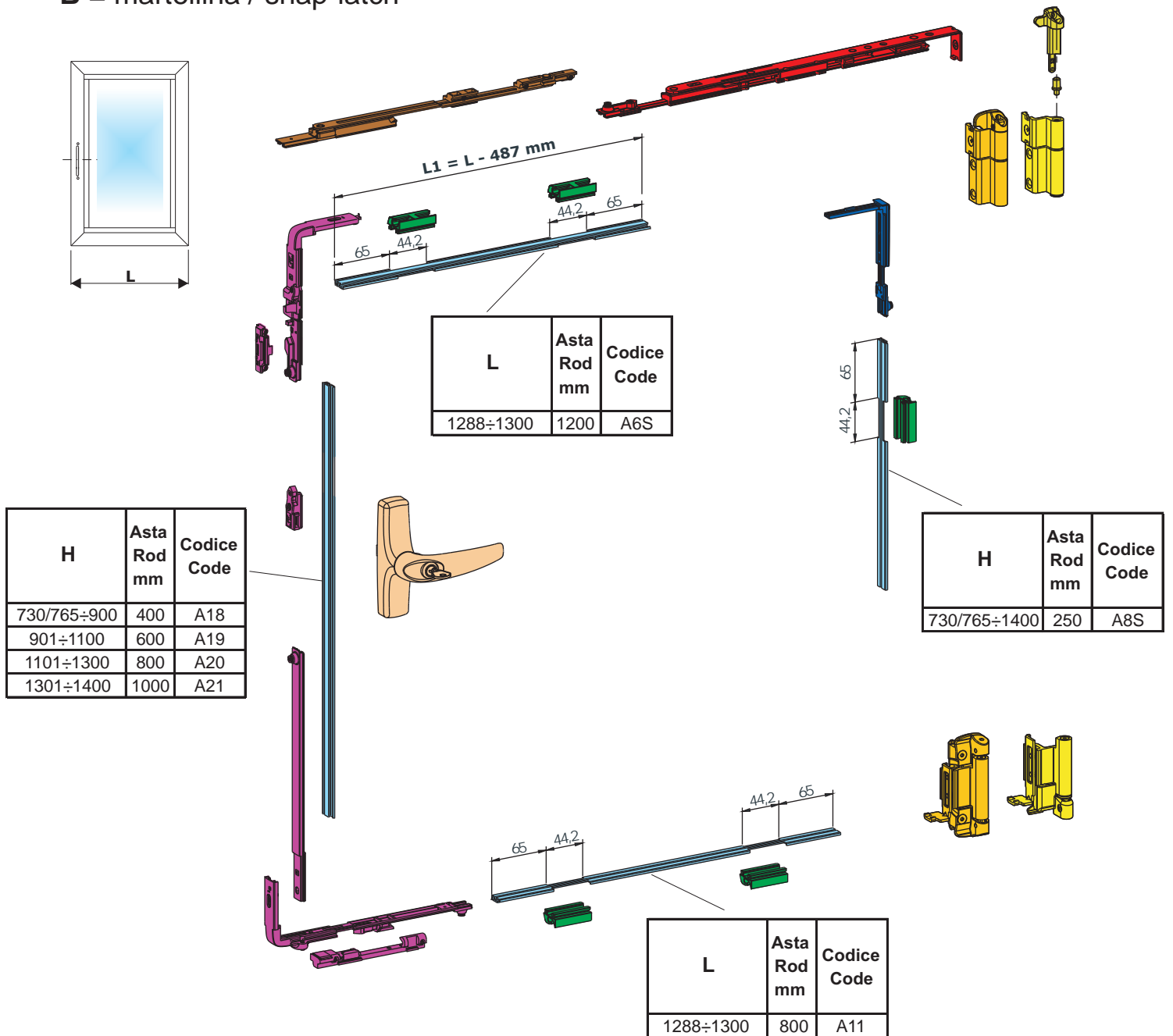

Per il posizionamento degli accessori sul telaio vedere pag. 17 - For accessories positioning on frame, see page 17

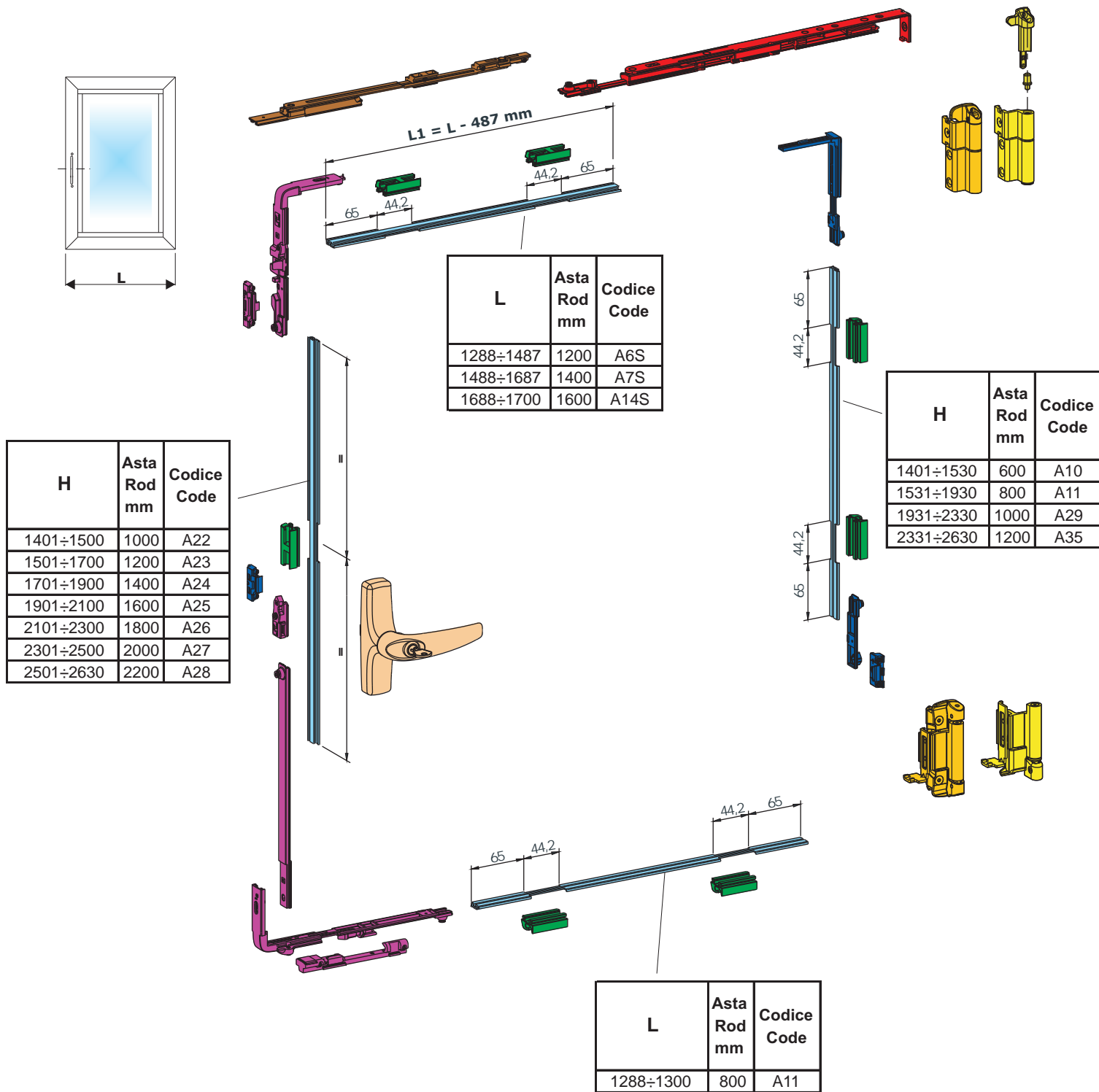

Per il posizionamento degli accessori sul telaio vedere pag. 17 - For accessories positioning on frame, see page 17

IV

(A) L=1301 ÷ 1700

H=730 ÷ 1400

(B) L=1301 ÷ 1700

H=765 ÷ 1400

A = cremonese / handle
 B = martellina / snap-latch

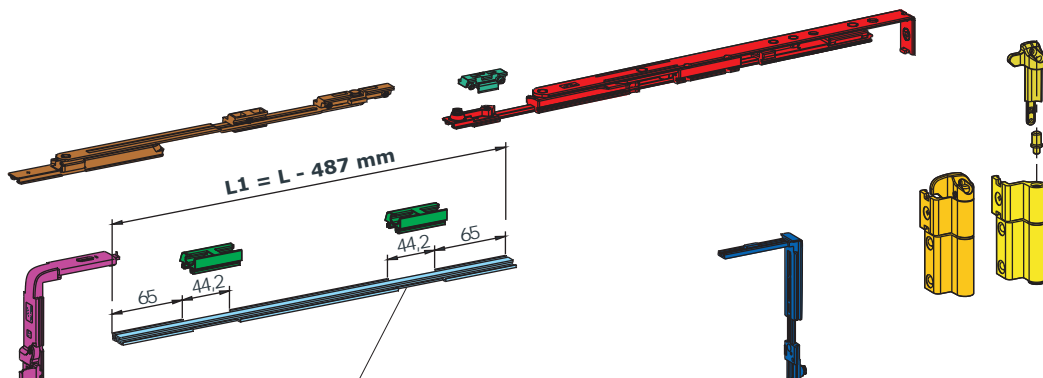
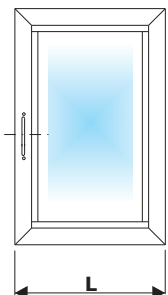

L	Asta Rod mm	Codice Code
1301÷1487	1200	A6S
1488÷1687	1400	A7S
1688÷1700	1600	A14S

H	Asta Rod mm	Codice Code
730/765÷900	400	A18
901÷1100	600	A19
1101÷1300	800	A20
1301÷1400	1000	A21

H	Asta Rod mm	Codice Code
730/765÷1400	250	A8S

L	X mm
1301÷1500	579
1501÷1700	679

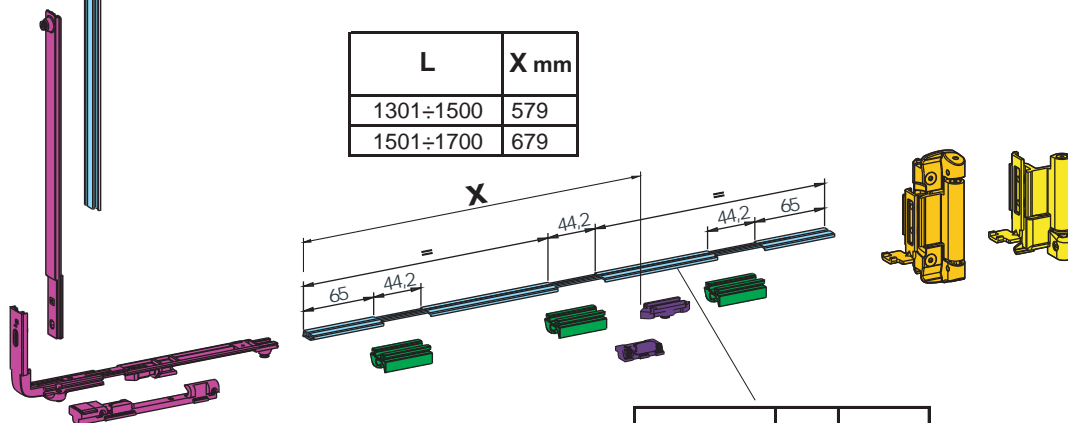

L	Asta Rod mm	Codice Code
1301÷1500	1000	A12
1501÷1700	1200	A13

Per il posizionamento degli accessori sul telaio vedere pag. 18 - For accessories positioning on frame, see page 18

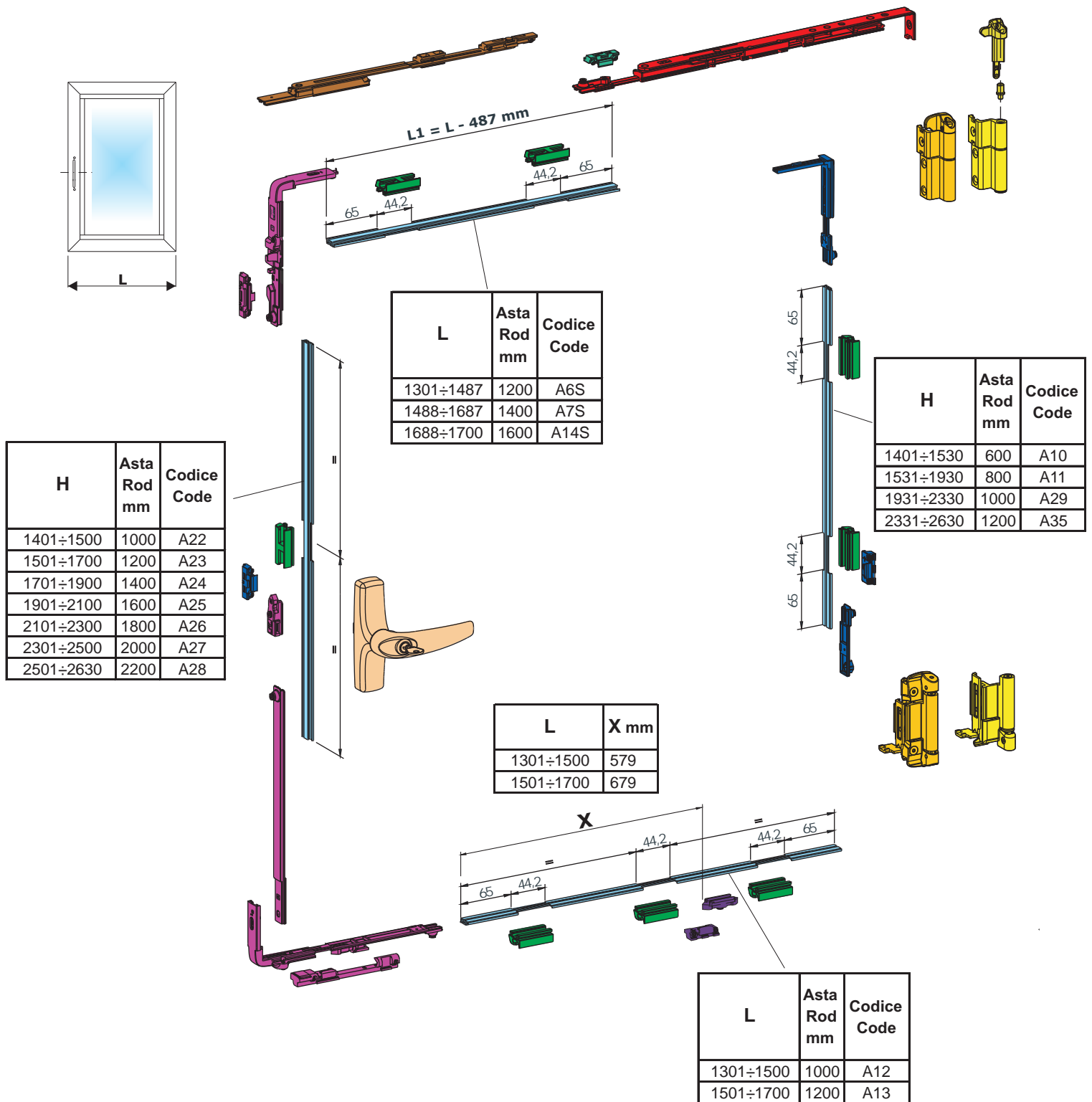

Per il posizionamento degli accessori sul telaio vedere pag. 18 - For accessories positioning on frame, see page 18

Sequenza di montaggio
Sequence assembly

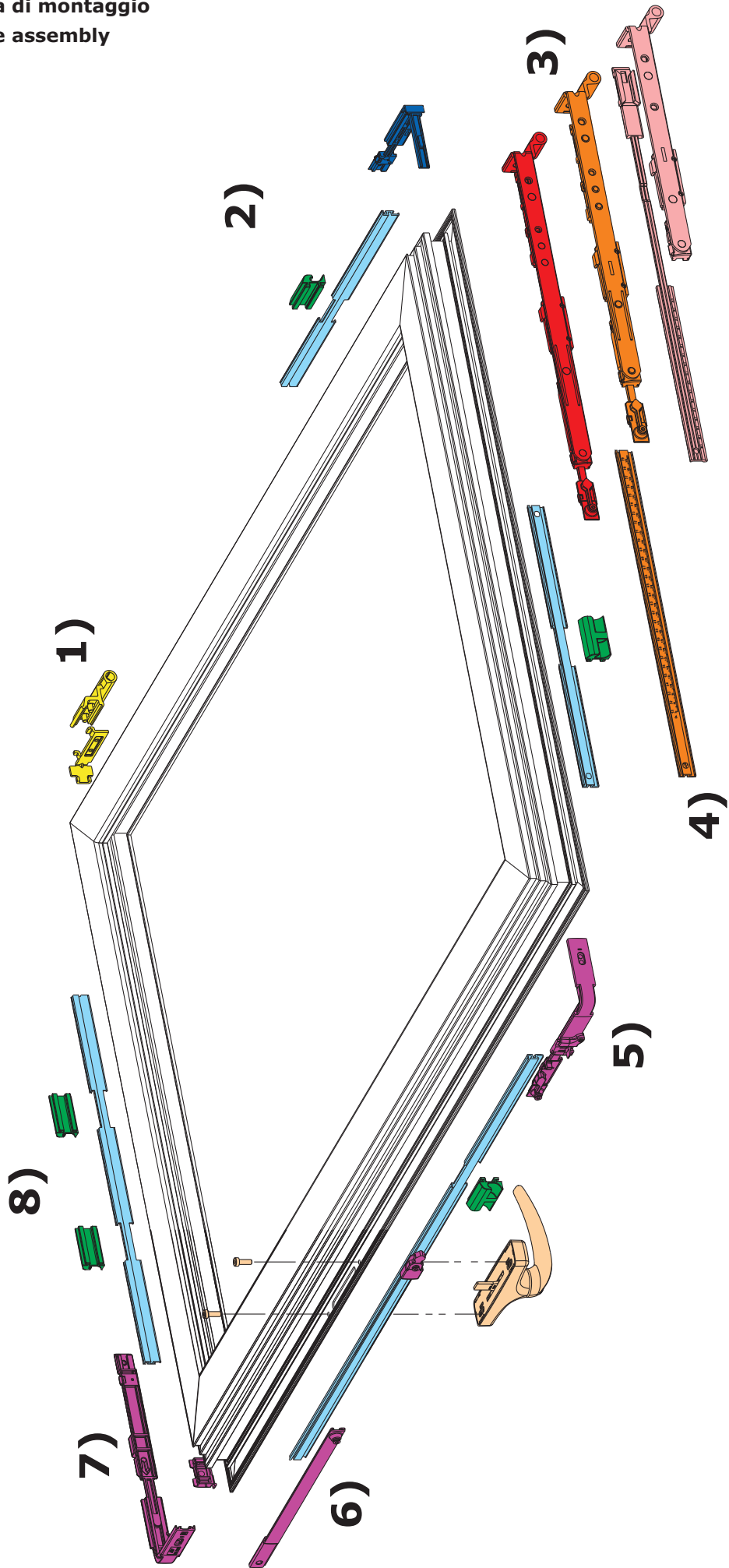

1)

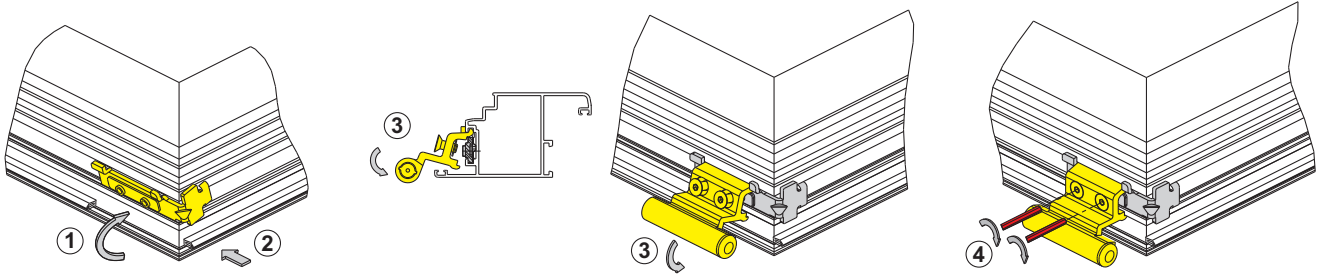

2)

Solo per i 6 punti di chiusura (H>1400 mm) - Only for 6 closing points (H>1400 mm)

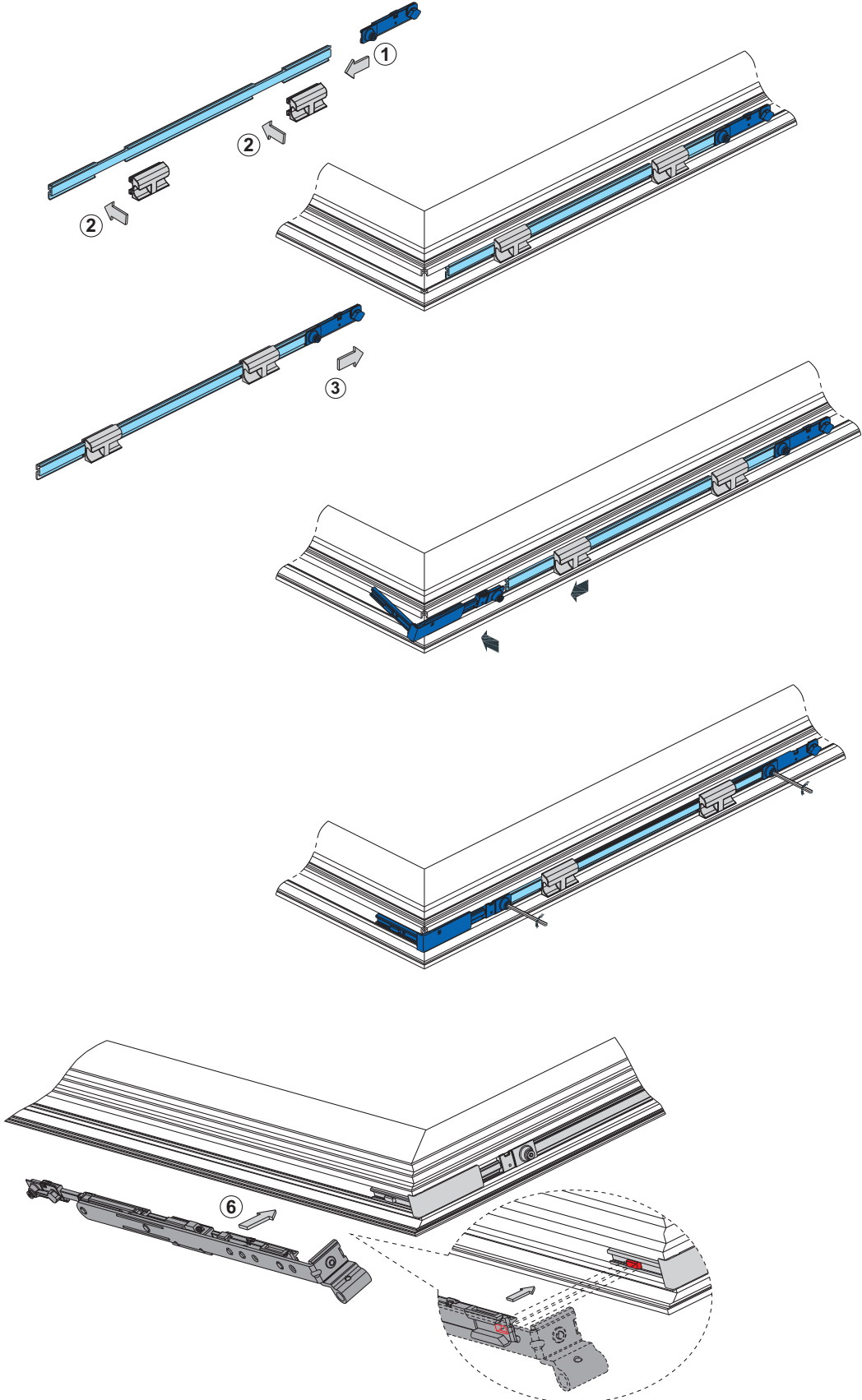

3) 360 < L < 509

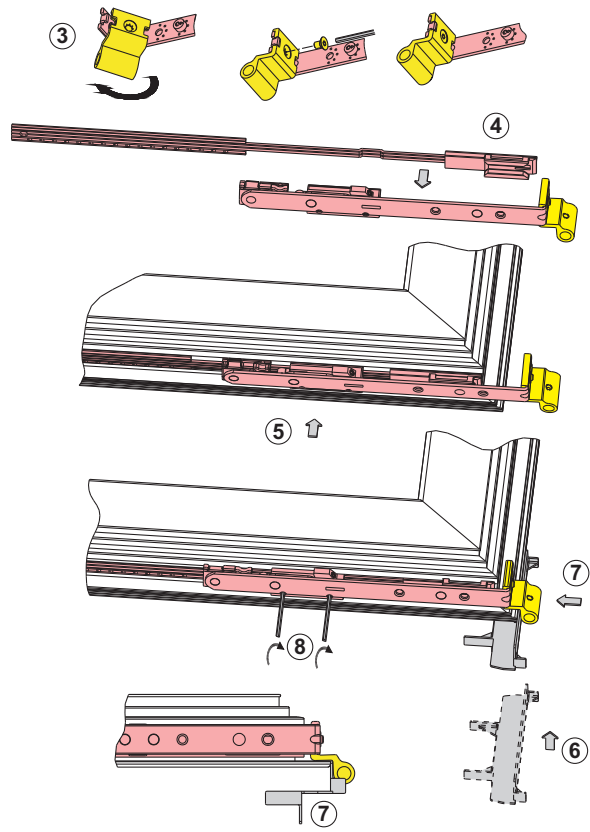
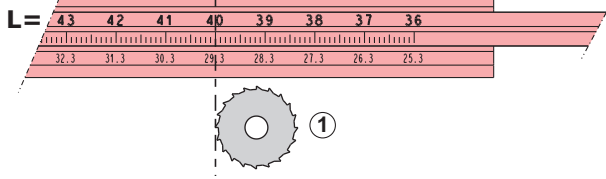
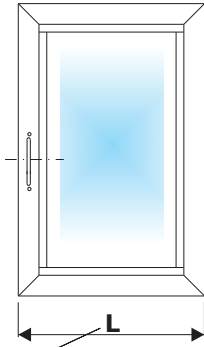
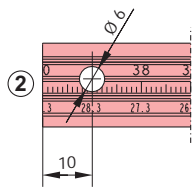

3a) 510 < L < 794

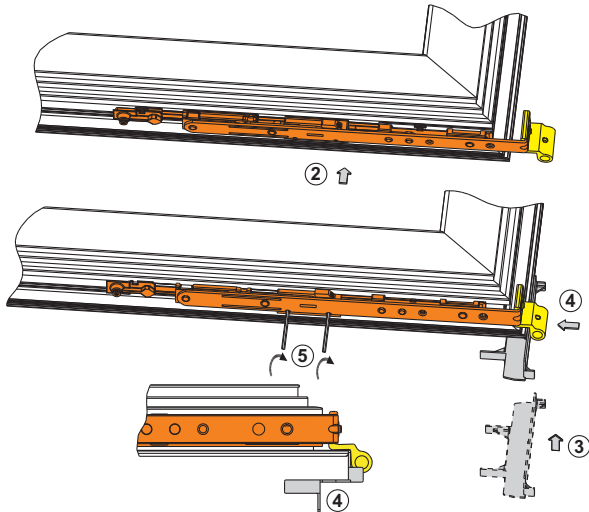
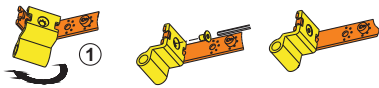

3b) 795 < L < 1700

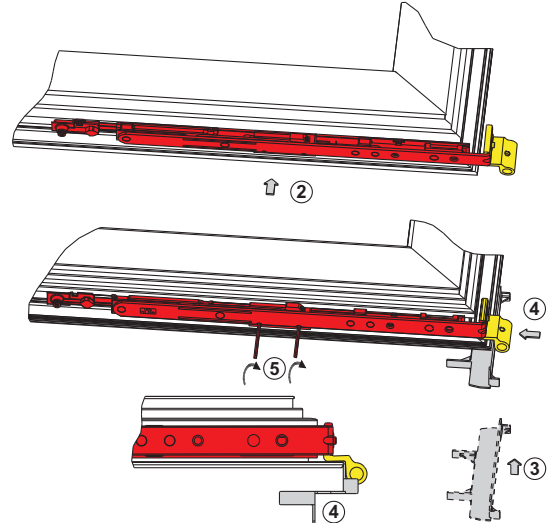
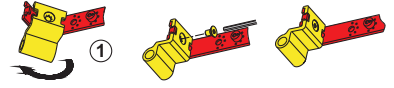

4a) 510 < L < 794

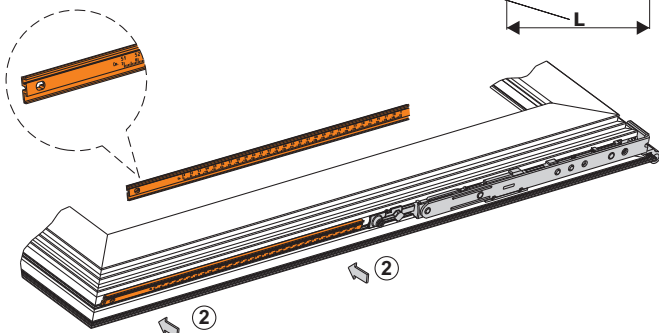
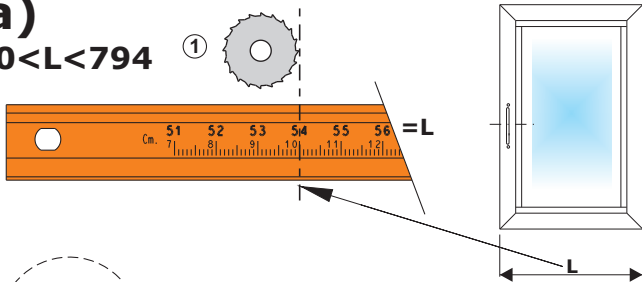

4b) 795 < L < 1700

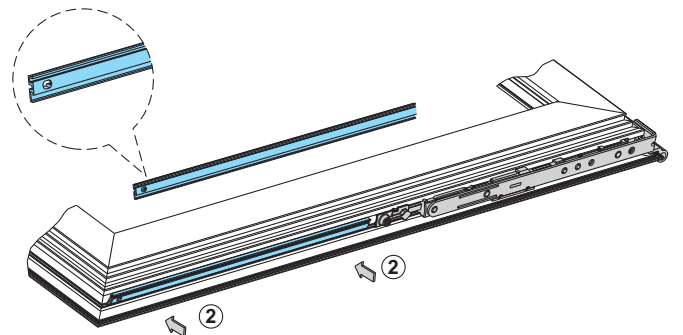

5) 360<L<509

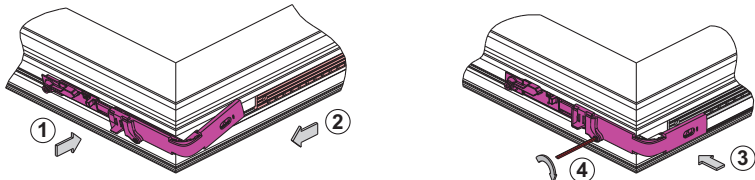

5b) 795<L<1700

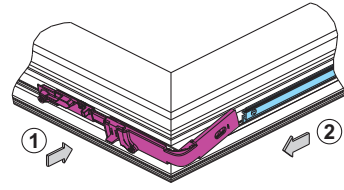

5a) 510<L<794

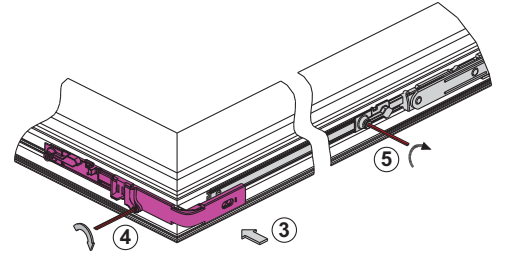
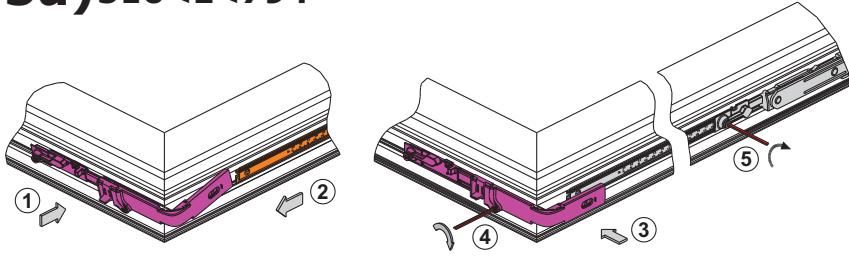

6) Con fulcro a rinvio d'angolo With corner transmission fulcrum

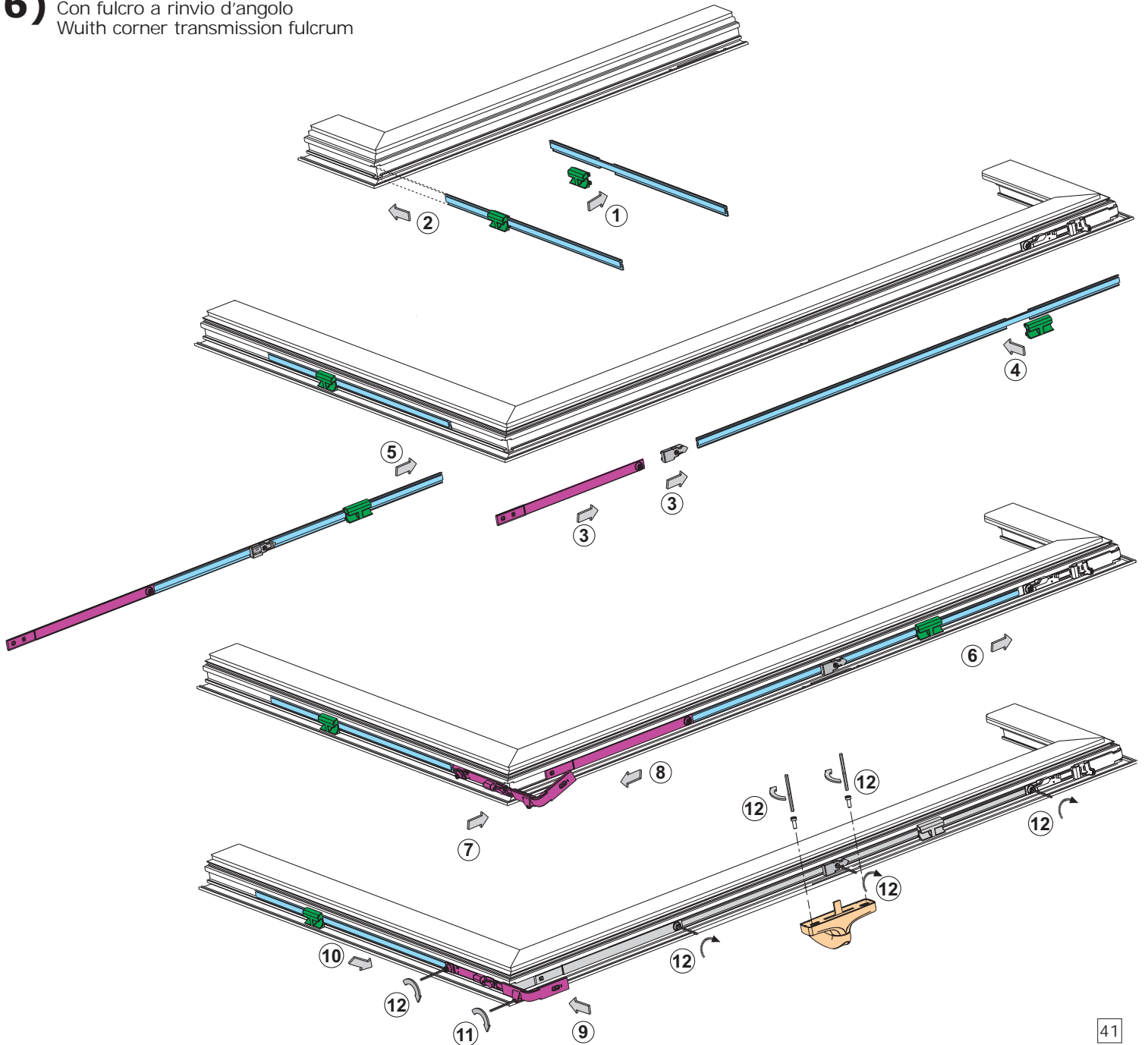

8)

Solo per i 8 punti di chiusura (L>1300 mm) - Only for 8 closing points (L>1300 mm)

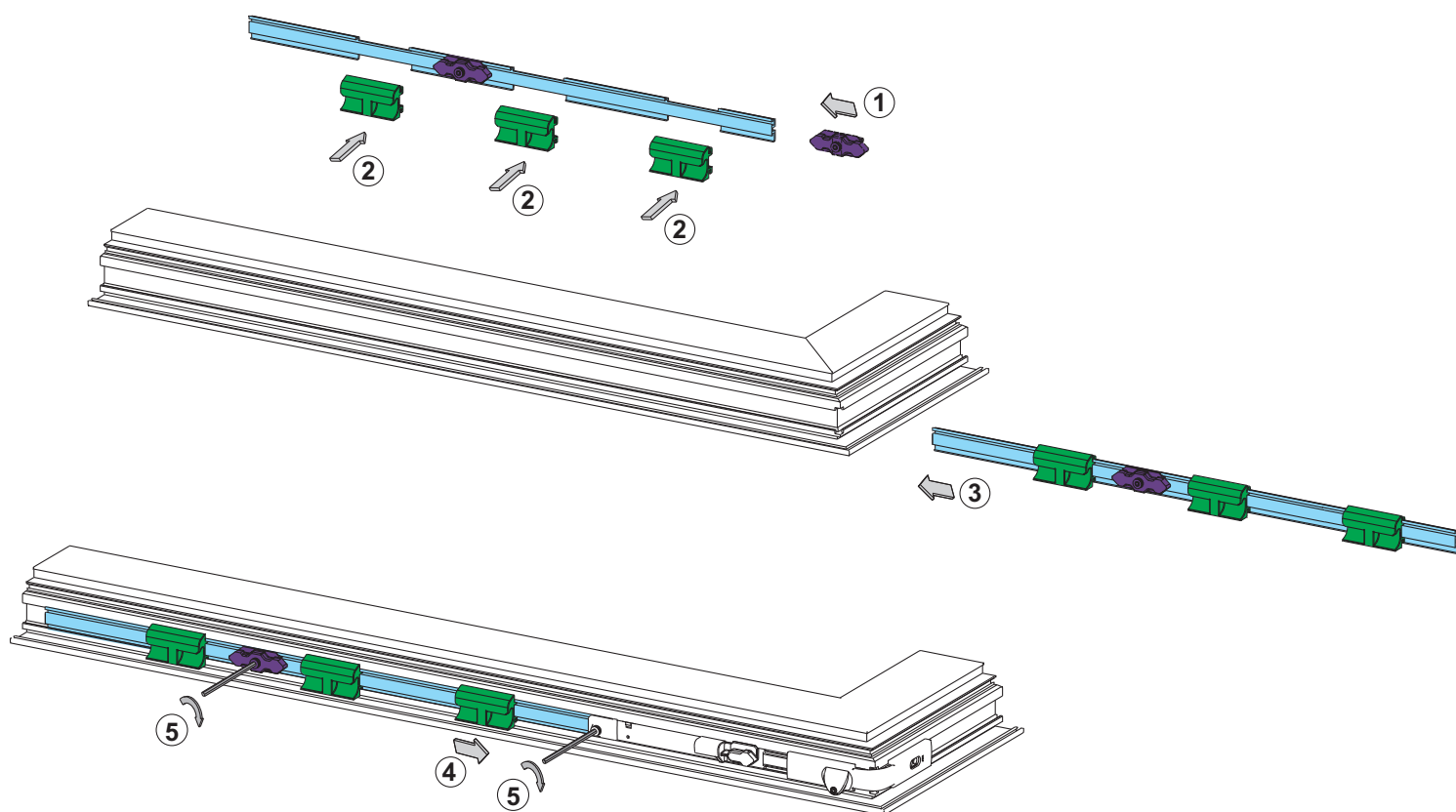

Sblocco dei componenti - Release of the components

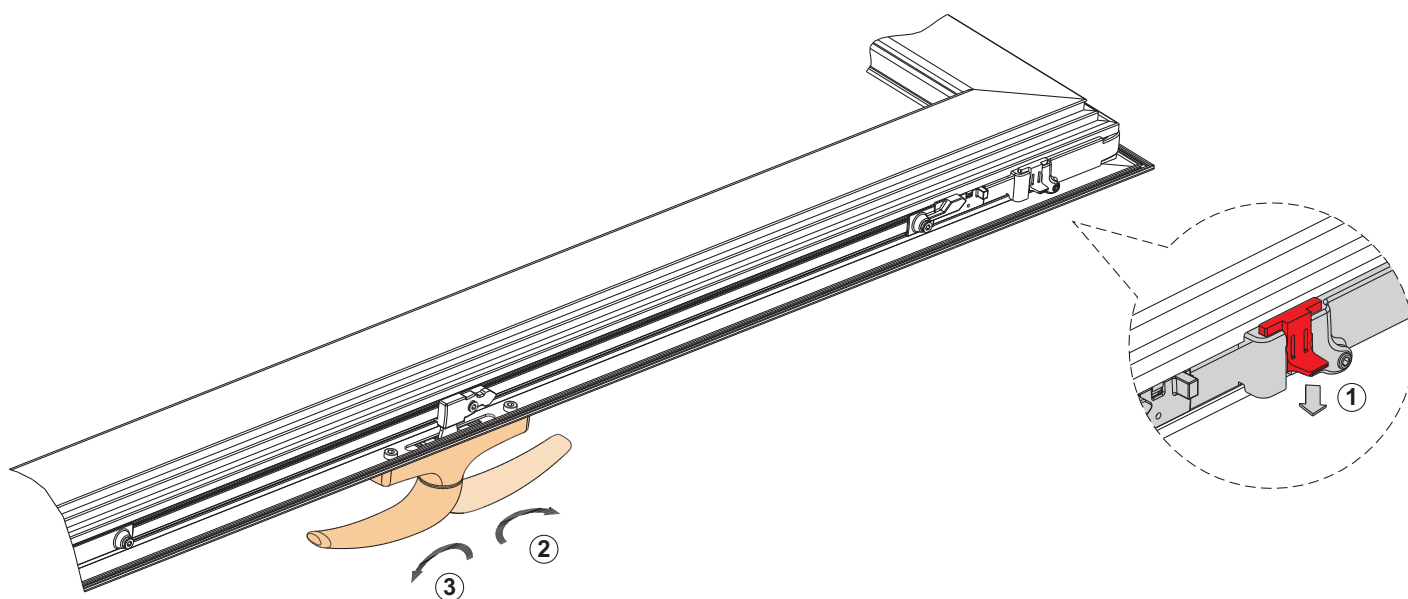

Regolazioni realizzabili

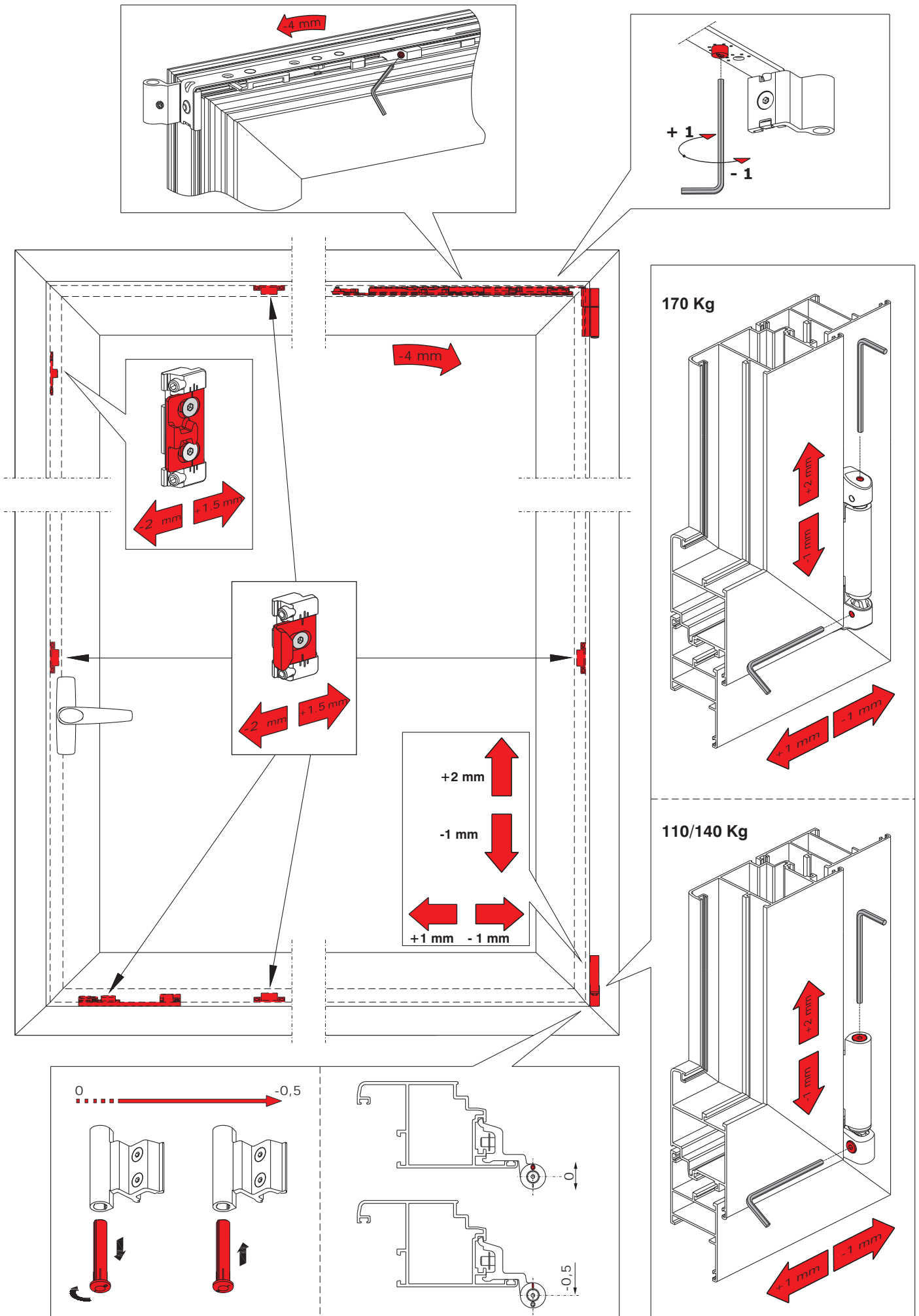

Microventilazione - Night ventilation

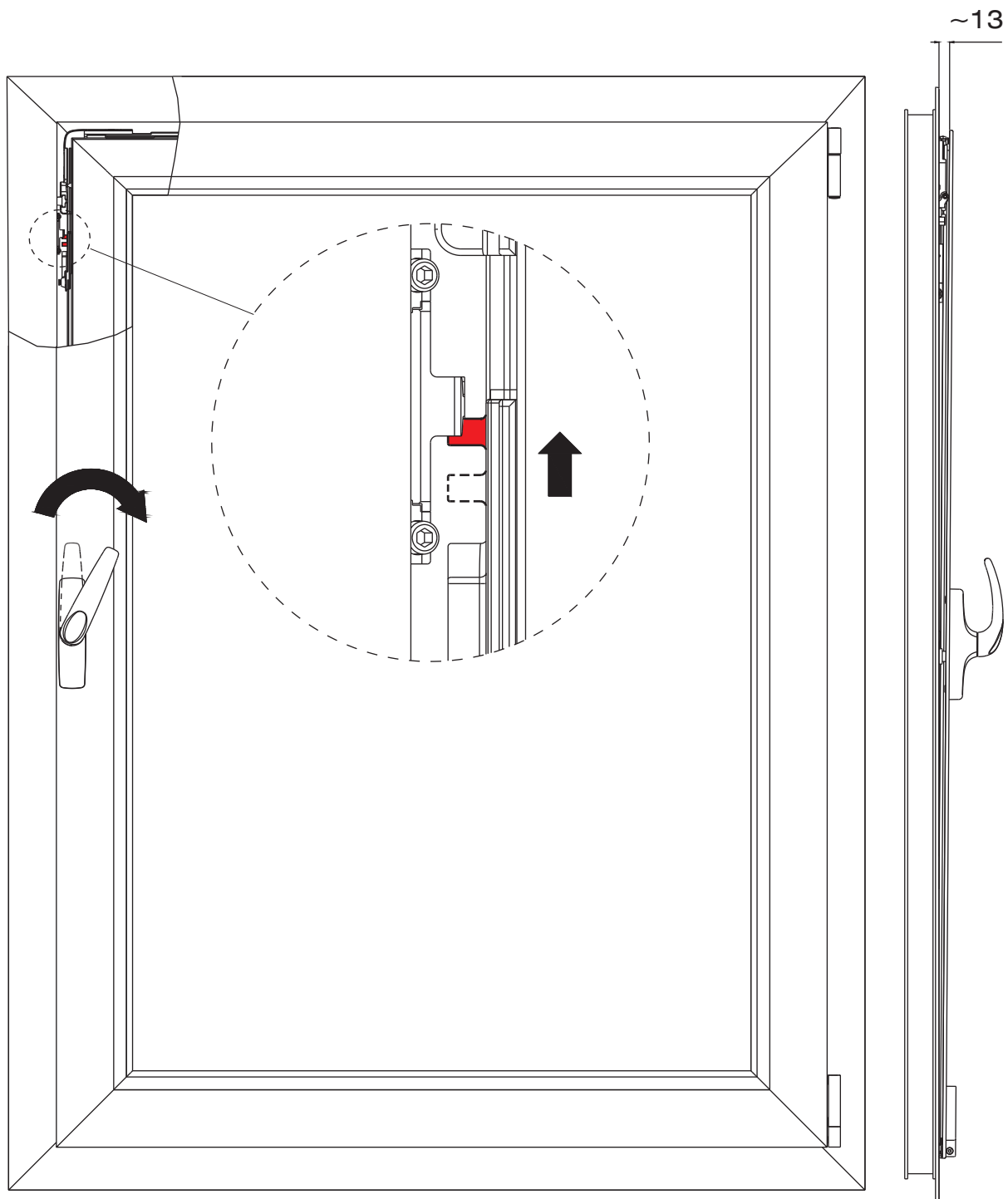

Per la microventilazione, con la cremonese in posizione di vasistas, scostare leggermente l'anta e ruotare la cremonese fino al blocco sull'incontro registrabile superiore.

To do the night ventilation opening, turn the handle in tilt position and open slightly the leaf, then turn the handle until the block on the upper adjustable keeper.

La SAVIO non risponde per vizi o danni causati dal mancato rispetto:

- del campo di applicazione (dimensioni, vetratura e numero dei punti di chiusura);
- delle indicazioni riportate su questo foglio di istruzioni per il montaggio;
- del non corretto e completo montaggio dei singoli particolari.

Rispetto alle presenti informazioni la SAVIO si riserva di apportare qualsiasi modifica in qualsiasi momento senza alcun preavviso. Si ricorda che il numero dei punti di chiusura per i diversi campi di applicazione illustrati, è puramente indicativo. L'ottenimento delle prestazioni finali del serramento (soprattutto se particolarmente pesante), è condizionato: dalla robustezza e dall'inerzia del profilo, dal funzionamento della guarnizione, dalla pressione su di esso determinata dalla sua posizione nell' edificio e dall' ubicazione di quest' ultimo. L' insieme di questi parametri potrebbe richiedere un numero di punti di chiusura superiore e/o posizionati diversamente.

Il perfetto funzionamento delle nostre anta-ribalta è garantito solo dall'uso delle nostre specifiche cremonesi.

SAVIO is not liable for defects or damage caused by failure to observe:

- the field of application (dimensions, glazing and number of locking points);
- the information contained in this assembly instructions sheet;
- incorrect or incomplete assembly of individual parts.

With respect to the present information SAVIO reserves the right to make any modifications it deems necessary at any time and without notice.

The number of locking points for the various fields of application illustrated in this instruction sheet is purely guideline. The final performance of the window (especially in the case of particularly heavy units), depends on: the strength and inertia of the profile, operation of the weather seal, the pressure exerted on the window in relation to the position of the window in the building and the site of the building. The combination of the foregoing parameters may result in the need for a greater number of locking points and/or different positioning of the locking points.

Perfect operation of our tilt-and-turn window is assured only when using our specific handles.

- 3 anni o 5.000 cicli

- 3 years or 5.000 cycles

