

Unico Flap

Meccanismo di apertura con cerniera integrata
Opening mechanism with integrated hinge



Unico Flap

Meccanismo di apertura con cerniera integrata

Opening mechanism with integrated hinge



Unico Flap è un meccanismo per ante a ribalta con cerniera integrata. Ha uno spessore di soli 12 mm (13,5 mm con cover).

È disponibile per tre tipi di applicazione:

- montaggio esterno con cover
- montaggio incassato in controspalla
- montaggio a filo con cover

Per ante con spessore da 18 mm. La posizione dell'anta è regolabile nelle tre dimensioni. Apertura e chiusura ottimizzabili grazie alla regolazione della forza della molla e della forza decelerante.

Materiali: acciaio, zama, tecnopolimero.

Colori cover: bianco segnale (RAL 9003), grigio seta (RAL 7044), grigio quarzo (RAL 7039), grigio ferro (RAL 7011), marrone grigiastro (RAL 8019), nero traffico (RAL 9017).

Unico Flap is a mechanism for downward flap doors with integrated hinge. It is just 12 mm thick (13,5 mm with the cover).

It is available for three types of applications:

- external mounting with cover
- recessed mounting in cover side panel
- recessed flush mounting with cover

You can mount doors with thickness from 18 mm. The position of the door is adjustable in the 3 dimensions. Opening and closing can be optimized thanks to the adjustment of the spring force and the decelerating force.

Materials: steel, zama, technopolymer.

Cover colors: white signal (RAL 9003), silk grey (RAL 7044), quartz grey (RAL 7039), iron grey (RAL 7011) greyish brown (RAL 8019), black traffic (RAL 9017).

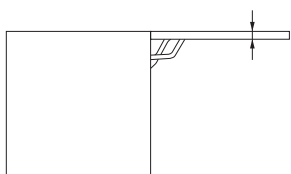

Spessore anta da 18 mm
Door's thickness from 18 mm

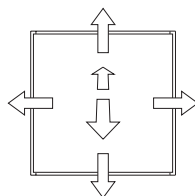

Regolazione orizzontale, verticale e frontale
Horizontal, vertical and frontal adjustment

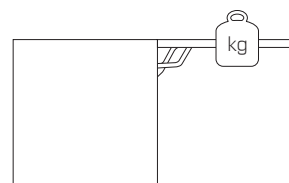

Regolazione forza della molla
Spring's force adjustment

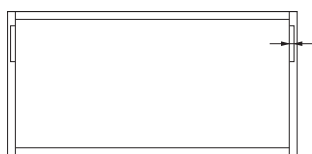

Spessore meccanismo ridotto
Narrow mechanism's thickness

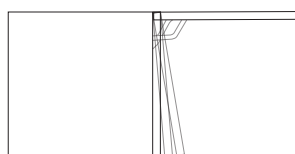

Chiusura ammortizzate
Soft closing

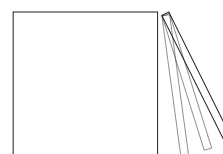

Regolazione forza decelerante
Decelerating force adjustment

Unico & Unico Flap



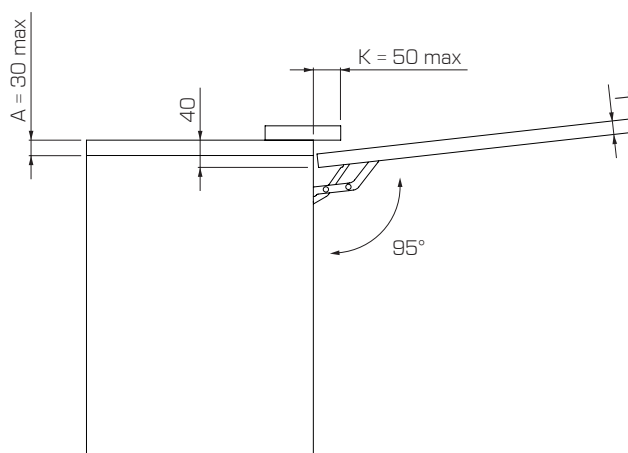
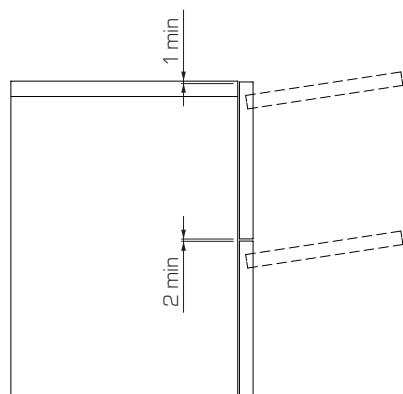

Per applicazioni con top sporgenti e per valori di T maggiori di 25 mm, preassemblare i meccanismi sull'anta e poi avvitarli nel mobile (T max = 30 mm).
For applications with protruding tops and for T values greater than 25 mm, pre-assemble the mechanisms on the door and then screw them into the cabinet (T max = 30 mm).

Finiture meccanismo
Mechanism's finishing



Nichelata
Nickel plated



Nichelata nera
Black nickel plated

Colori standard cover (RAL)
Cover's standard colors (RAL)



Bianco segnale
Signal white
RAL 9003



Grigio seta
Silk grey
RAL 7044



Grigio quarzo
Quartz grey
RAL 7039



Marrone grigiastro
Grey brown
RAL 8019



Grigio ferro
Iron grey
RAL 7011



Nero traffico
Traffic black
RAL 9017

Per informazioni riguardanti quantità minime ordinabili e colori personalizzati rivolgersi a: info@effegibrevetti.com.
For information about minimum order quantities and custom colors please contact: info@effegibrevetti.com.



Montaggio esterno con cover
External mounting with cover

$$D = S + 1$$



Montaggio incassato in controspalla
Recessed mounting in cover side panel

$$D = S + 1$$



Montaggio esterno con cover a filo
External mounting with flush cover

$$D = S - 13,5$$

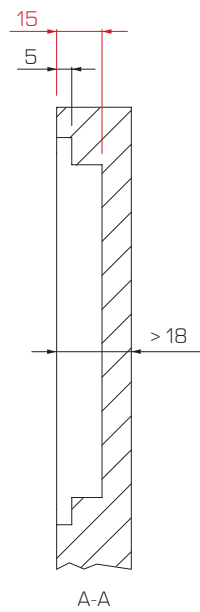
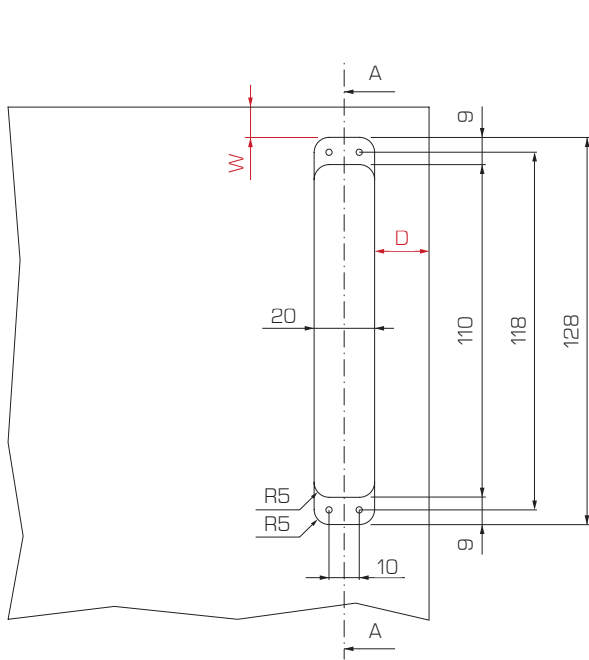

Y	W
1	11
1,5	10,5
2	10
2,5	9,5
3	9
4	8
5	7

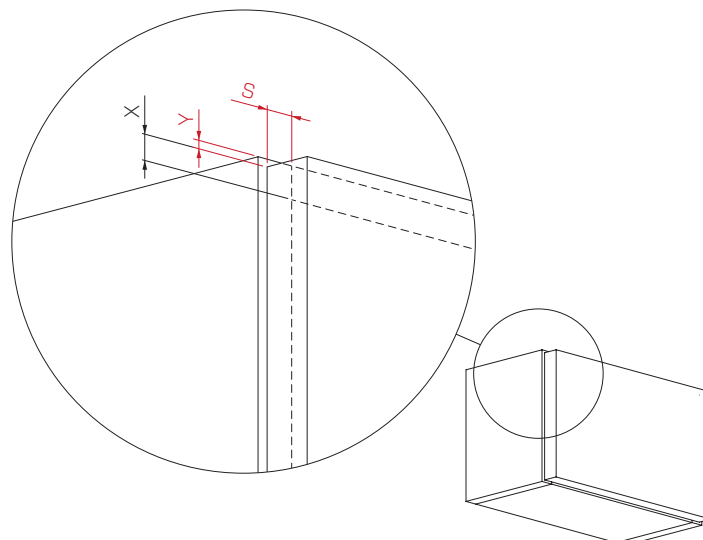

Lavorazioni spalla (montaggio esterno con cover e montaggio incassato in contropalla)

Side panel's workings (external mounting with cover and recessed mounting in cover side panel)



Montaggio esterno con cover
External mounting with cover



Montaggio incassato in contropalla
Recessed mounting in cover side panel

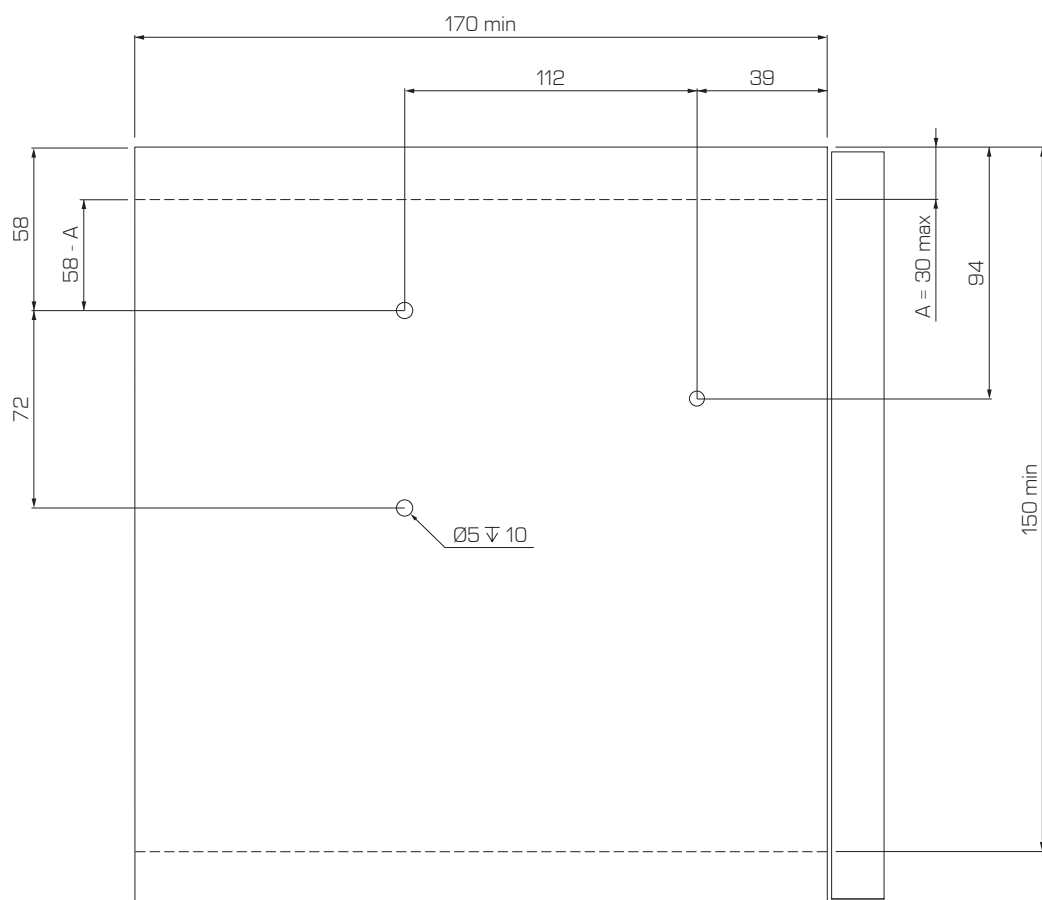

Lavorazioni contropalla (montaggio incassato in contropalla)
Cover side panel's workings (recessed mounting in cover side panel)



Montaggio incassato in contropalla
Recessed mounting in cover side panel

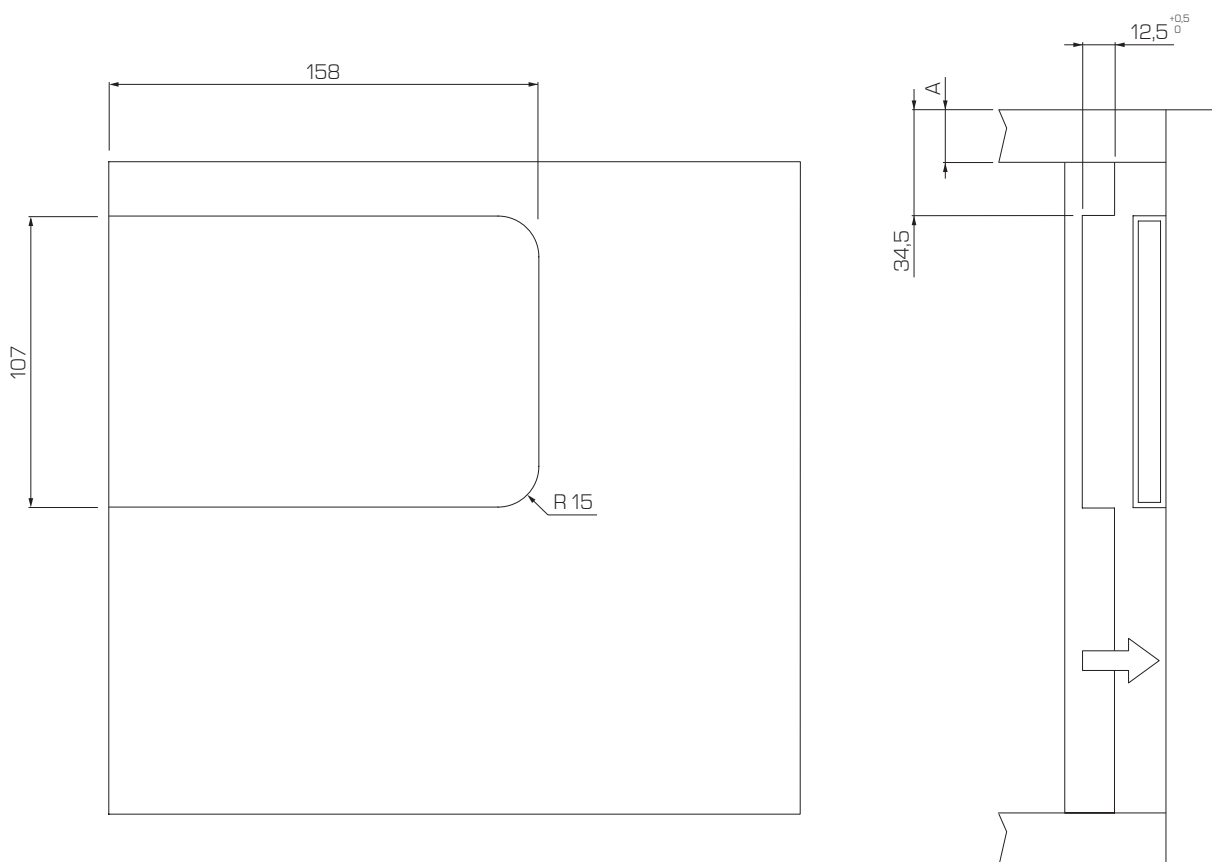

Foratura spalla (montaggio esterno con cover a filo)
Side panel drilling (external mounting with flush cover)



Montaggio esterno con cover a filo
External mounting with flush cover

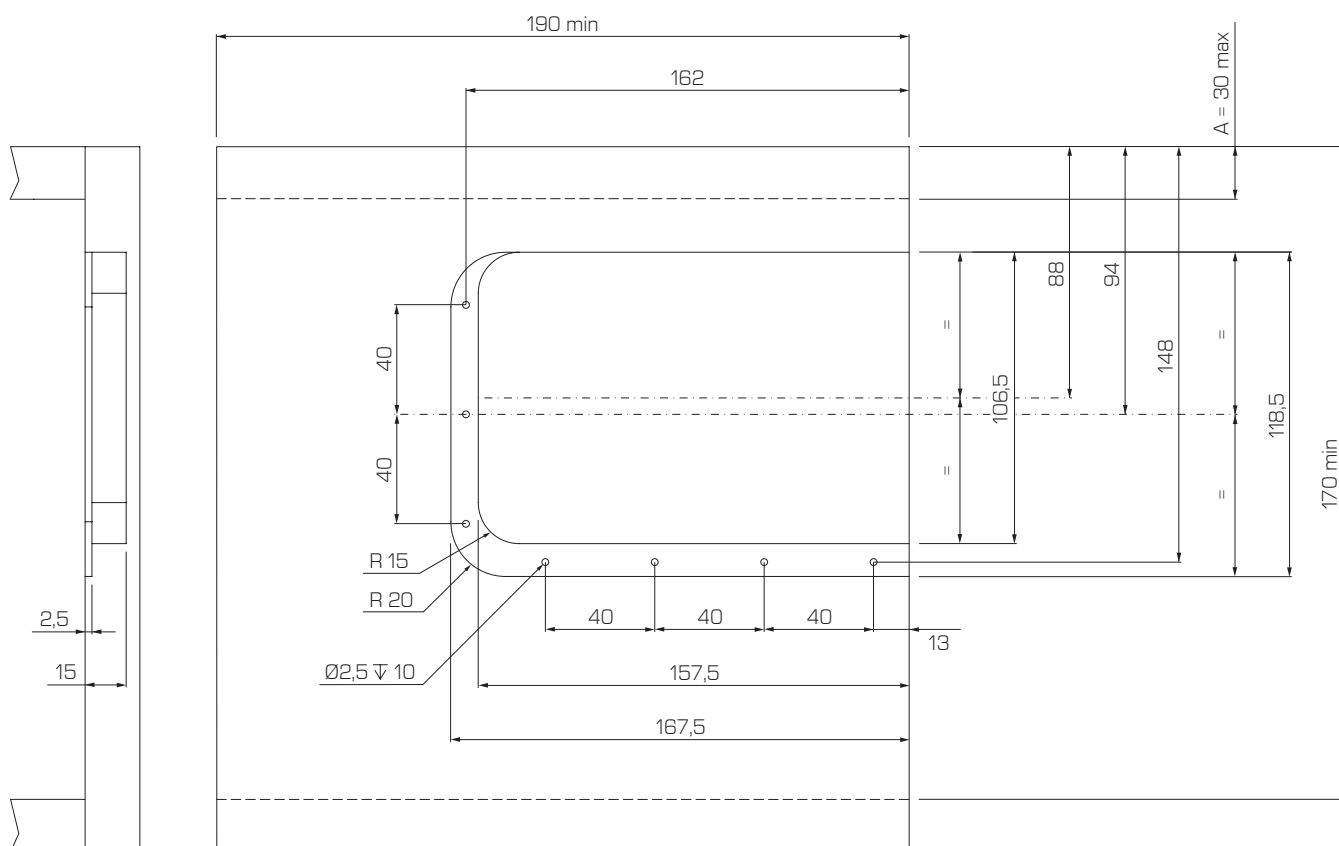

Montaggio meccanismo
Mechanism mounting

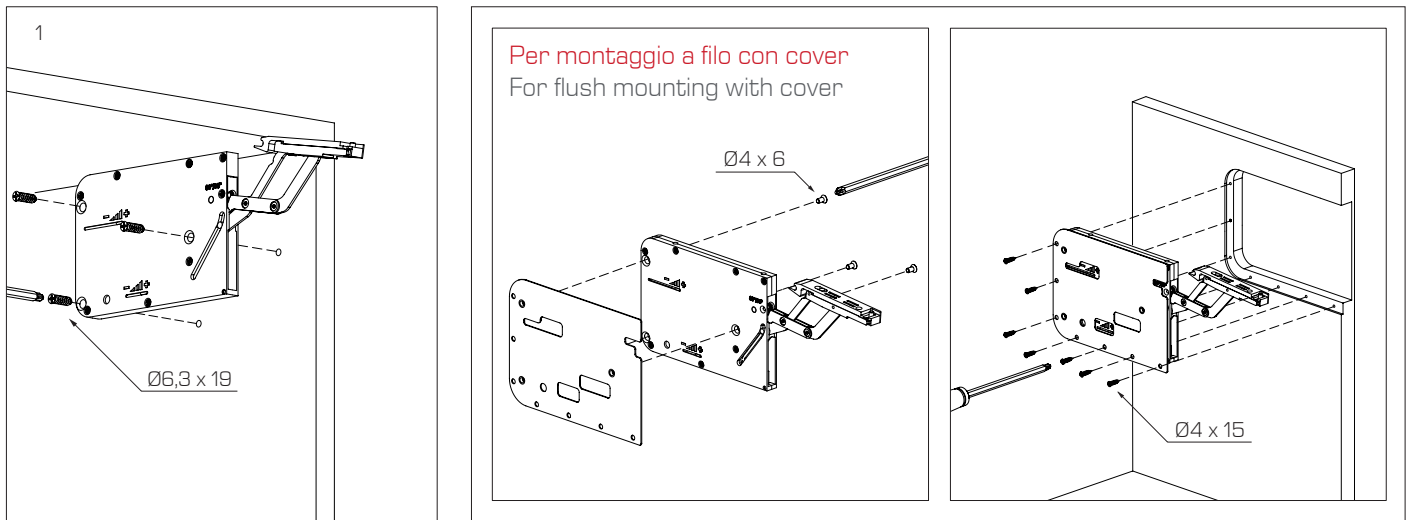

Fissaggio attacco anta
Door connection fixing

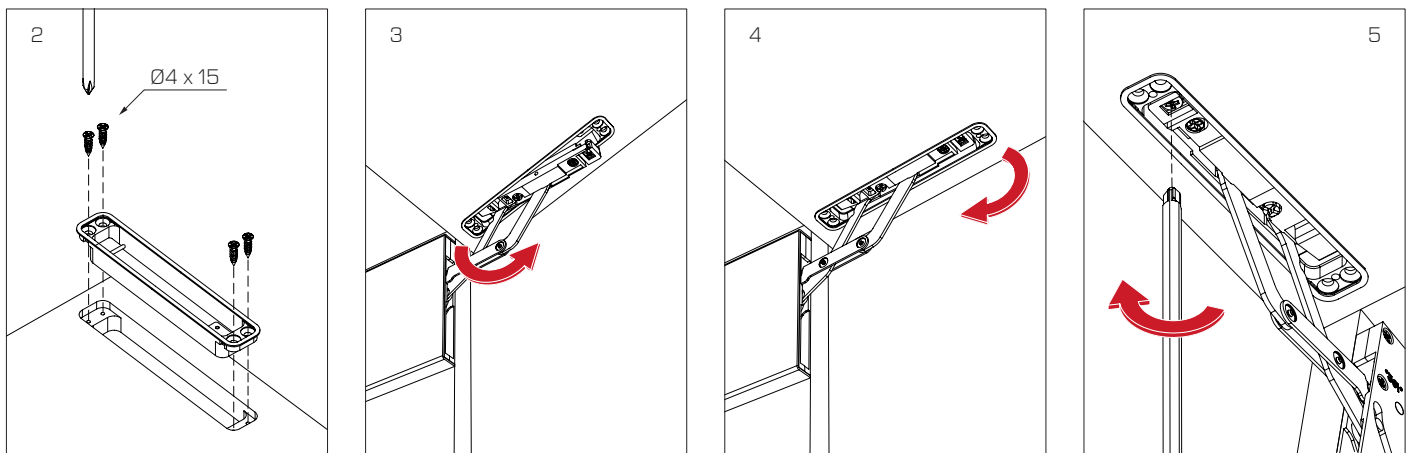

Rimozione fermo
Stop removal

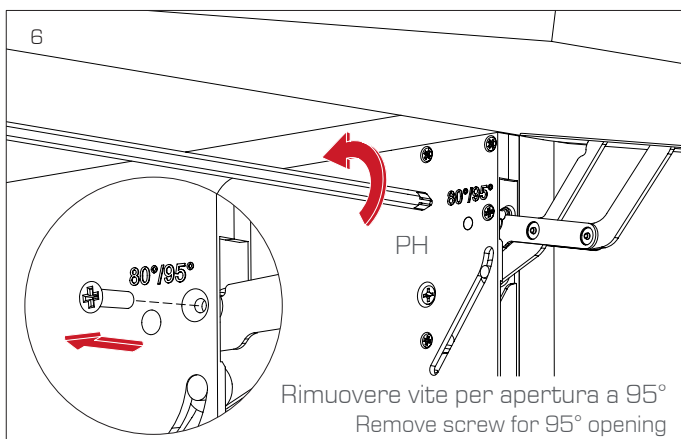

Fissaggio cover attacco anta
Door connection cover fixing

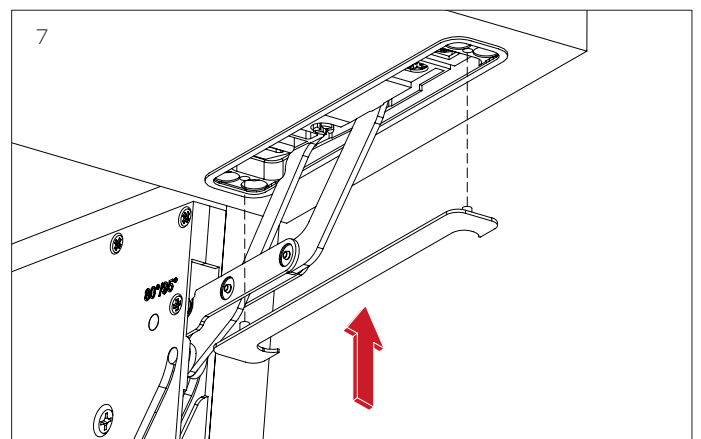

Montaggio cover
Cover mounting

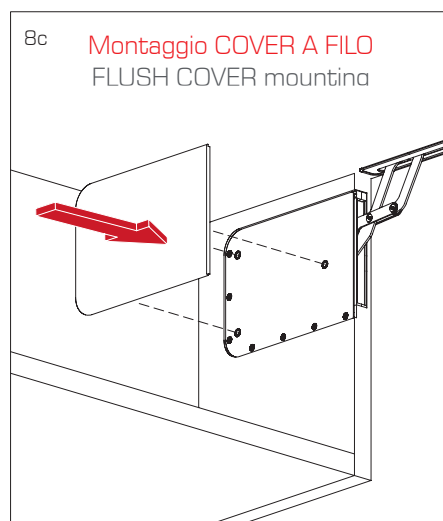
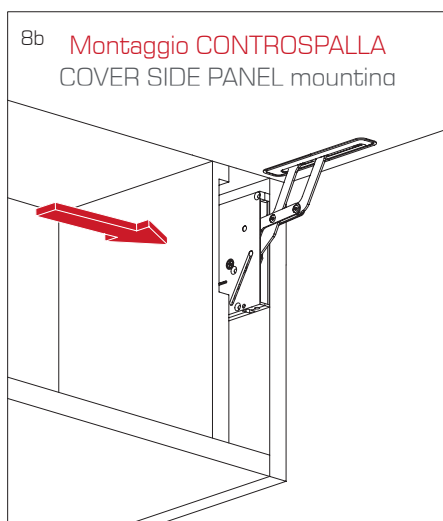

Regolazioni
Adjustments



Tabelle pesi anta (kg)
Door weight tables (kg)



Hp	Config. 1	Config. 2	Config. 3	Config. 4
180 - 230	2,0 - 5,0*	5,1 - 7,5*	-	-
231 - 270	1,5 - 4,5*	4,6 - 7,2*	-	-
271 - 330	1,5 - 4,0*	4,1 - 7,0	7,1 - 9,0	9,1 - 11,5
331 - 380	1,5 - 3,8	3,9 - 6,5	6,6 - 8,0	8,1 - 11,0
381 - 430	2,0 - 3,0	3,1 - 6,0	6,1 - 7,0	7,1 - 10,0
431 - 480	-	2,5 - 5,5	5,6 - 6,8	6,9 - 8,5

***Per queste configurazioni e pesi anta, disattivare uno dei due ammortizzatori.**
***For these configurations and door's weights, deactivate one of the two dampers.**

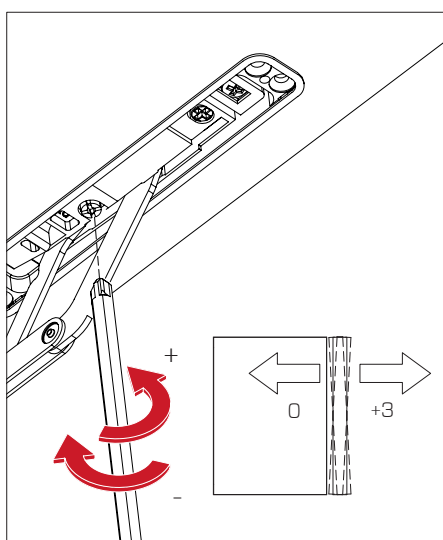
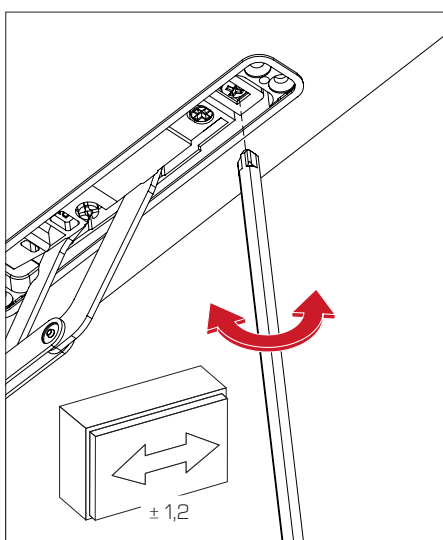
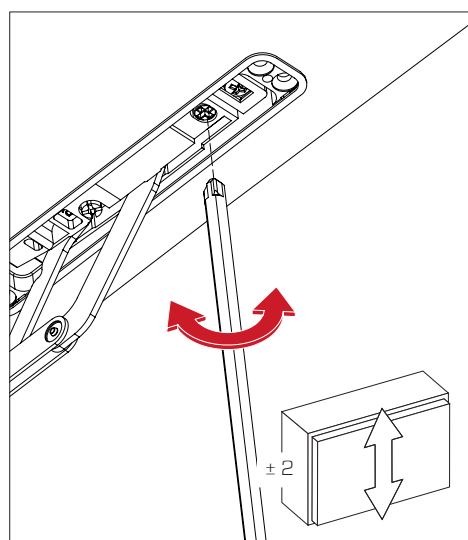
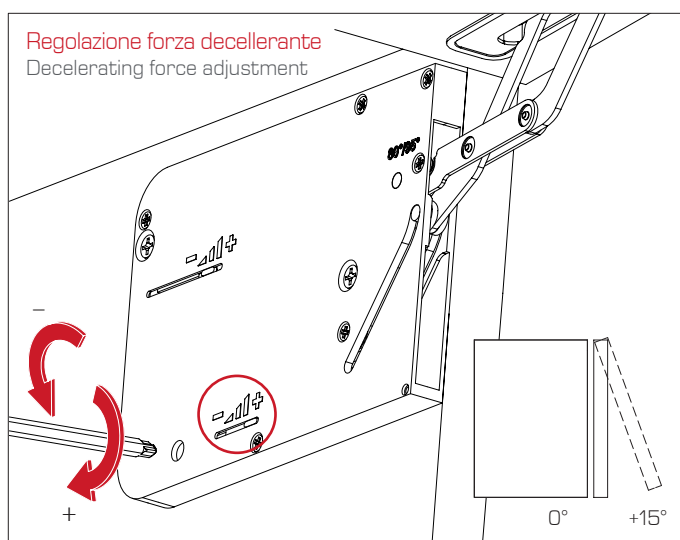
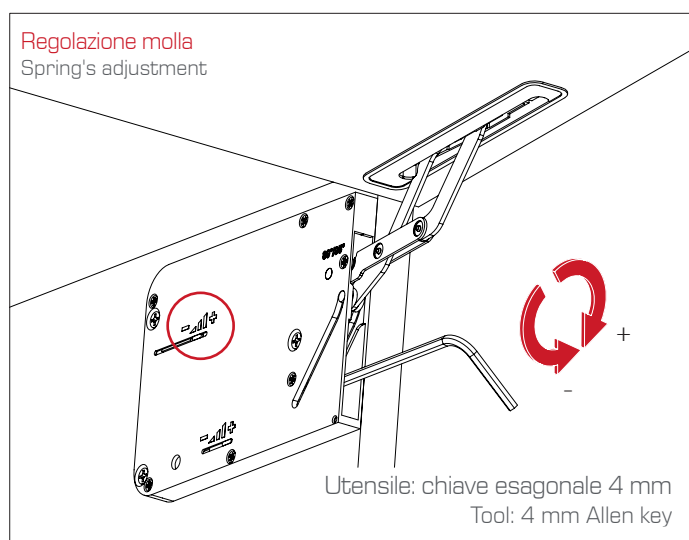
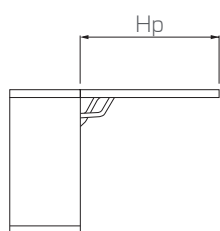

ATTENZIONE WARNING

Il peso e la posizione della maniglia possono influenzare le prestazioni del meccanismo.
The weight and position of the handle may influence the performance of the mechanism.

Imballaggio
Packaging

Montaggio esterno con cover
External mounting with cover

1 SET di meccanismi (dx+sx)
1 SET of mechanisms (left+right)

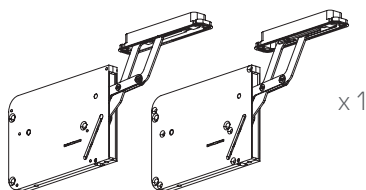

10 SET di cover
(per meccanismi e attacchi anta)
10 SET of covers
(for mechanisms and door connections)

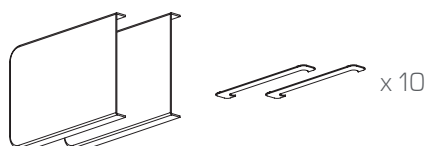

Montaggio incassato in contropalla
Recessed mounting in cover side panel

1 SET di meccanismi (dx+sx)
1 SET of mechanisms (left+right)

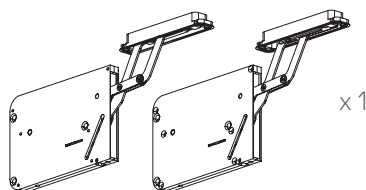

20 cover (per attacchi anta)
20 covers (for door connections)



Montaggio esterno con cover a filo
External mounting with flush cover

1 SET di meccanismi (dx+sx)
1 SET of mechanisms (left+right)

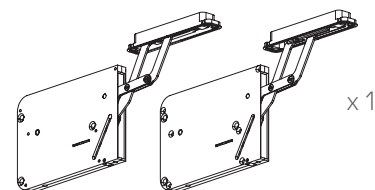

10 SET di piastre (dx+sx)
10 SET of plates (left+right)

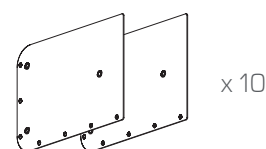

10 SET di cover
(per meccanismi e attacchi anta)
10 SET of covers
(for mechanisms and door connections)

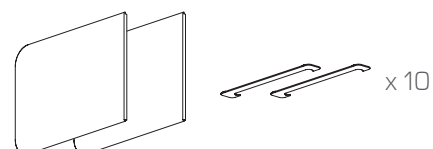

Incluso nel catalogo Effegibrevetti:

Cerniere per:

- Ante a battente
- Ante a ribalta

Fissaggi:

- Orizzontali
- Verticali
- A scatto
- Livellatori
- Reggipiani

Meccanismi per:

- Ante a ribalta
- Ante a pantografo
- Ante a pacchetto
- Ante scorrevoli
- Apertura obliqua
- Apertura verticale

Effegibrevetti ha la facoltà di apportare ai prodotti tutte le modifiche e migliorie tecniche.

Included in Effegibrevetti's catalogue:

Hinges for:

- Swing doors
- Flap doors

Fittings:

- Horizontal
- Vertical
- Snap
- Levellers
- Shelf supports

Mechanisms for:

- Flap doors
- Pantograph doors
- Folding doors
- Sliding doors
- Oblique opening
- Vertical opening

Effegibrevetti reserve the right to make changes and technical improvements to the products.

EFFEGIBREVETTI 

Effegibrevetti S.r.l.

Via Cava Trombetta 17/25
20054 Segrate Milano Italy

COMPANY WITH
QUALITY SYSTEM
CERTIFIED BY DNV
ISO 9001